

The logo for STIX, consisting of a red square followed by the letters "STIX" in a bold, black, sans-serif font.

BG0100 Rev 05.5
Magnetic Corrosion Scanner

The logo for JIREH, featuring a red square with a white stylized "J" inside, followed by the word "JIREH" in a bold, black, sans-serif font.

SAFETY WARNINGS \ PRECAUTIONS

KEEP THIS MANUAL – DO NOT LOSE

THIS MANUAL IS PART OF THE **STIX** AND MUST BE RETAINED FOR THE LIFE OF THE PRODUCT. PASS ON TO SUBSEQUENT OWNERS.
Ensure any amendments are incorporated with this document.



WARNING! The **STIX** is designed for a specific use. Using the **STIX** outside of its intended use could cause damage to the product. Read and understand this manual before using.



WARNING! MAGNETIC MATERIAL. The wheels of this device produce a magnetic field which may cause failure or permanent damage to items such as watches, memory devices, CRT monitors, medical devices or other electronics.



People with pacemakers or ICD's must stay at least 25 cm (10 in) away at all times.



WARNING! Do **NOT** operate scanner in an explosive environment. Do **NOT** operate scanner in the presence of volatile substances.



WARNING! DO NOT DISASSEMBLE. No user-serviceable parts. Disassembling any of the components in this product, beyond the instructions in this user manual, could void the regulatory certifications and/or effect the safety of the product.



The **WEEE** symbol indicates that the product must not be disposed of as unsorted municipal waste, but should be collected separately.

(see *Disposal* on page 34)

TABLE OF CONTENTS

1	Identification	1
	1.1. Product Brand	1
	1.2. Manufacturer	1
2	Product Specifications	2
	2.1. Intended Use	2
	2.1.1. Operating Limits	2
	2.1.2. Operating environment	2
	2.2. Dimensions and Weight	2
	2.3. Environmental Sealing.....	3
	2.4. Performance Specifications	3
3	Definitions	4
	3.1. Definition of Symbols	4
4	System Components	5
	4.1. Component Identification	5
	4.2. Tools	6
	4.3. Corrosion Link	7
	4.4. Non-Encoded Corrosion Link	7
	4.4.1. Corrosion link adjustment.....	8
	4.4.2. Mounting a Frame Bar	9
	4.4.3. Index Encoder Connection	9
	4.4.4. Encoder Connection	9
	4.4.5. Brake	10
	4.4.6. Wheel Removal/Installation	10
	4.5. Carrier	11
	4.5.1. Carrier Cable Clip	11
	4.5.2. Index Nuts	12
	4.6. Heavy Duty Vertical Probe Holder	13

4.6.1. Probe Holder Setup	13
4.6.2. Probe Holder Vertical Adjustment.....	14
4.6.3. Probe Holder Left/Right Conversion	15
4.6.4. Yoke Substitution	16
4.6.5. Probe Holder 90° Adjustment.....	17
4.7. Frame Bar with Ruler	17
4.8. Pivot Buttons	17
4.9. Index Encoder	18
4.10. Cable Clips.....	19
4.11. Cable Management	19
4.11.1. Cable Management Dovetail Mount	20
4.11.2. Cable Management Setup	20
4.11.3. Clamp Setup	21

5	Configuration	22
	5.1. Standard Configuration	22
6	Operation	23
	6.1. Setup of a STIX on a Scanning Surface	23
7	Maintenance	25
8	Troubleshooting	26
	8.1. Technical Support	26
9	Service and Repair	27
10	Spare Parts	28
	10.1. Corrosion Scanner	28
	10.2. Kit Components	29
	10.2.1. Encoder Connector Type	30
	10.2.3. Cable Management Length	30
	10.3. Accessories	30
	10.3.1. Magnetic Wheel Kit	30
	10.3.2. Preamp Bracket	31
	10.3.3. HydroFORM™ Cart	31
	10.4. Heavy Duty Vertical Probe Holder	32

10.5.Probe Holder Components 33
10.5.1. Heavy Duty Yoke Style33
10.5.2. Pivot Button Style33

11 Disposal34

12 Limited Warranty35

IDENTIFICATION

1.1. Product Brand

This user manual describes the proper safety precautions, setup and use of the **STIX** manual magnetic corrosion scanner.

1.2. Manufacturer

Distributor:

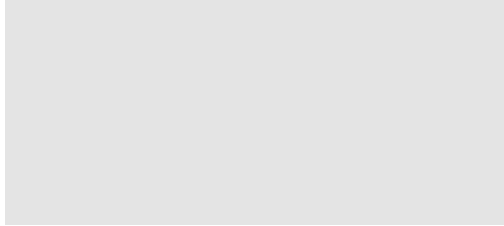

Manufacturer:

Jireh Industries Ltd.
53158 Range Road 224
Ardrossan, Alberta, Canada
T8E 2K4
Phone: 780.922.4534
jireh.com

PRODUCT SPECIFICATIONS

2.1. Intended Use

The **STIX** magnetic scanner is a manually operated scanner which provides corrosion scanning.

2.1.1. Operating Limits

	Minimum	Maximum
Pipe/tube range, outer diameter (standard)	20.3 cm (8 in)	Flat
Pipe/tube range, outer diameter (reduced)	10.2 cm (4 in)*	Flat

* 10.2 cm (4 in) diameter scanning is made possible when using the reduced width of the corrosion link (see *Corrosion link adjustment on page 8*).

2.1.2. Operating environment

The **STIX** magnetic scanner is designed for use in an industrial environment that is between -20° C (-4° F) and 50° C (122° F).

2.2. Dimensions and Weight

Encoder cable length (standard kit)	5 m (16.4 in)
Scanner width (Fig. 1-1)	76.7 cm (30.2 in)
Scanner length (Fig. 1-2)	25.4 cm (10 in)
Scanner height (Fig. 1-3)	15 cm (5.9 in)
Scanner weight	3.9 kg (8.6 lb)

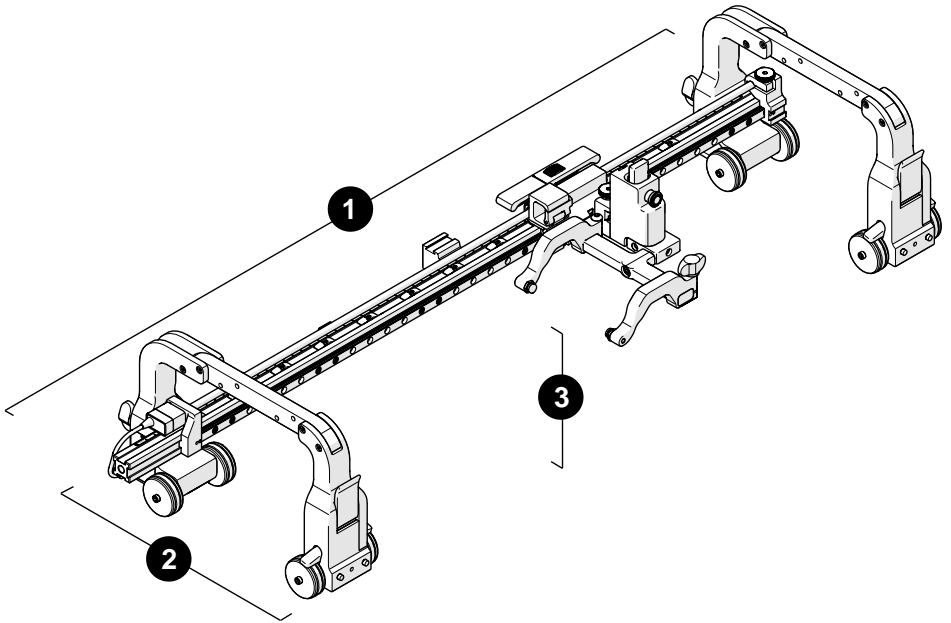

Fig. 1 - Scanner dimensions

2.3. Environmental Sealing

Dust-tight, watertight (*not submersible*).

2.4. Performance Specifications

Scan encoder resolution	16.3 counts/mm (<i>414.5 counts/inch</i>)
Index Encoder resolution	40.3 counts/mm (<i>1023.9 counts/inch</i>)

DEFINITIONS

3.1. Definition of Symbols



Instructions to 'look here' or to 'see this part.'

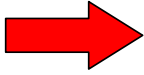

Denotes movement. Instructing users to carry out an action in a specified direction.

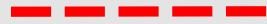

Indicates alignment axis.



Alerts the user that the view has changed to a reverse angle.

SYSTEM COMPONENTS

4.1. Component Identification

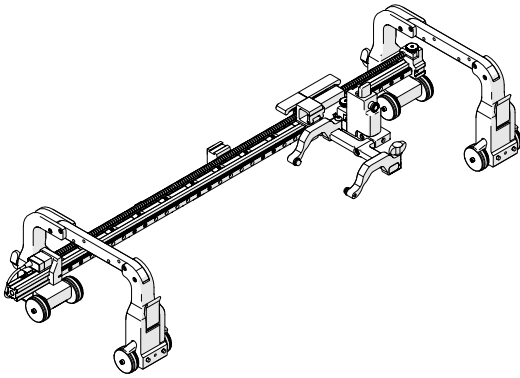

Fig. 2 - STIX - Corrosion scanning
BGA012-

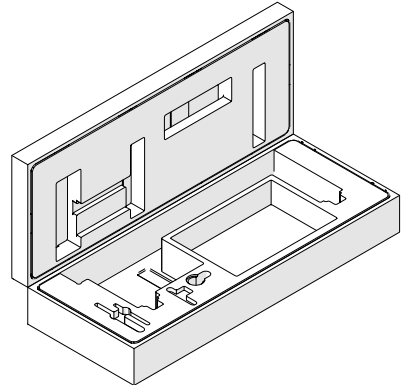

Fig. 3 - STIX corrosion case
BGA017

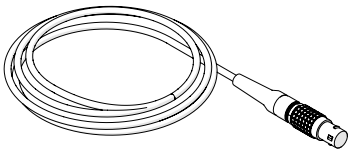

Fig. 4 - J100 Encoder Cable
UMA026-

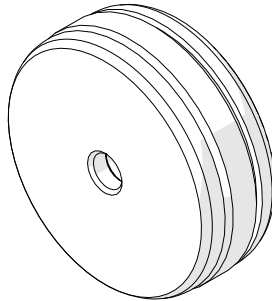

Fig. 5 - Magnetic Wheel
BTS031

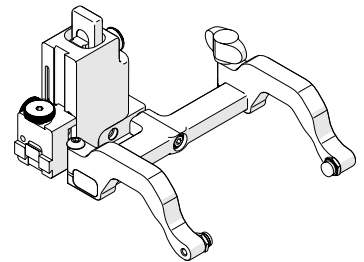

Fig. 6 - Heavy Duty Vertical Probe Holder
PHS043-

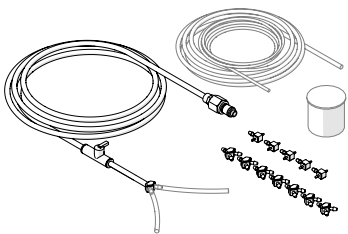

Fig. 7 - Irrigation Kit
CMG007

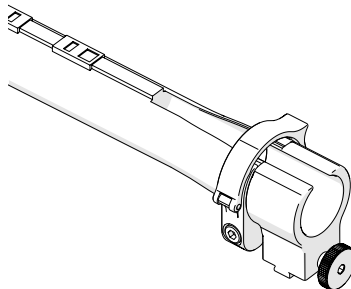

Fig. 8 - Cable management - dovetail mount
CES044-

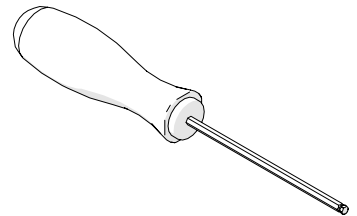

Fig. 9 - 3 mm Hex Driver
EA414

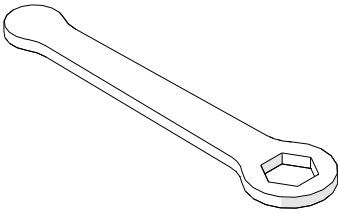

Fig. 10 - 3/8 in wrench
EA470

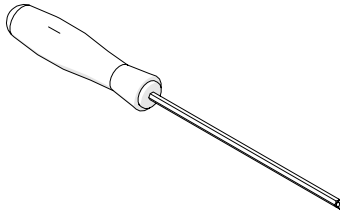

Fig. 11 - 2 mm hex driver
EA476

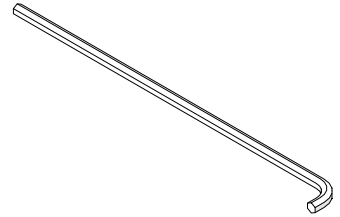

Fig. 12 - Short 2 mm Hex Wrench
CE0137

4.2. Tools

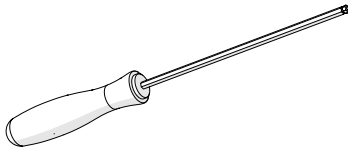

Fig. 13 - 2 mm hex driver

The 2 mm hex driver (*Fig. 13*) allows for adjustment of the index nuts.

The 3 mm hex driver (*Fig. 14*) is sufficient for all typical operations and adjustments of the **STIX**.

The 3/8 in wrench (*Fig. 15*) removes and installs buttons on the probe holders.

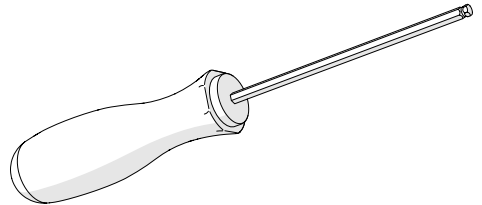

Fig. 14 - 3 mm hex driver

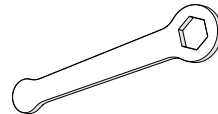

Fig. 15 - 3/8 in wrench

4.3. Corrosion Link

The corrosion link (Fig. 16) provides braking for the system and an internal encoder connected to the wheels. A connection plug exists for index encoding.

A mounting point for the frame bar is also provided.

The corrosion link length can be adjusted to increase the scanner diameter range and allow for probe clearance.

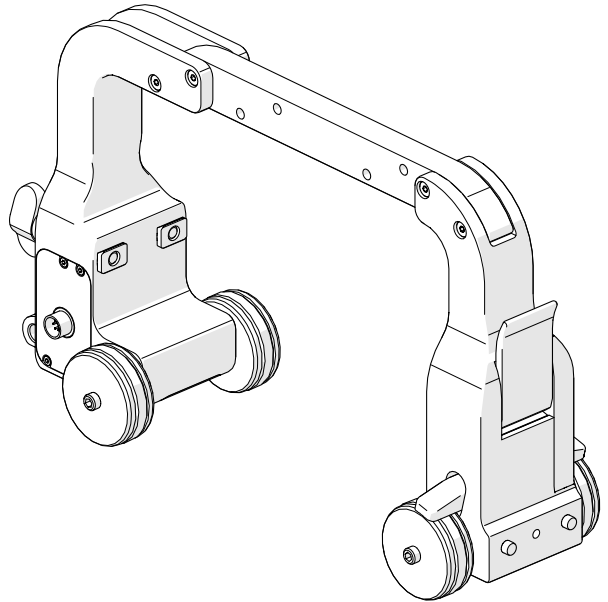

Fig. 16 - Corrosion link

4.4. Non-Encoded Corrosion Link

The non-encoded corrosion link (Fig. 17) provides braking for the system.

A mounting point for the frame bar is also provided.

The corrosion link length can be adjusted to increase the scanner diameter range and allow for probe clearance.

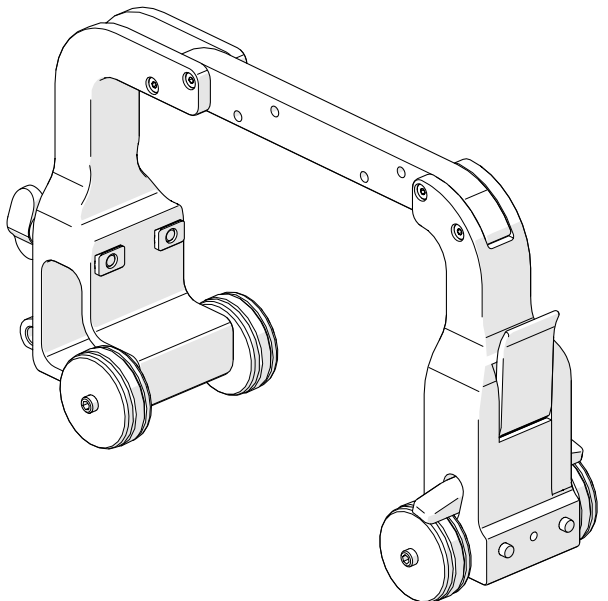

Fig. 17 - Non-Encoded Corrosion link

4.4.1. Corrosion link adjustment

To achieve the minimum diameter pipe/tube scan range of 10.2 cm (4 in), the corrosion and non-encoded corrosion links must be adjusted as follows.

NOTE: The large yoke of the heavy duty probe holder must be replaced with the standard yoke to allow the carrier to fit under the corrosion links (see *Yoke Substitution* on page 16).

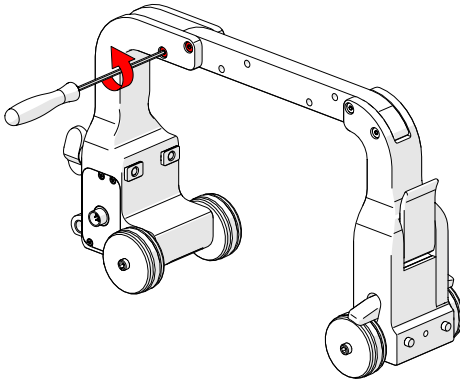

Fig. 18 - Remove shoulder screws

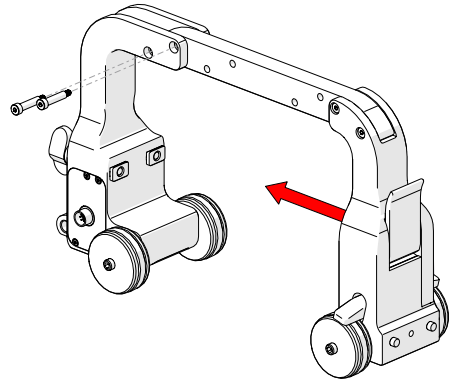

Fig. 19 - Align screw holes

1. Use the supplied 2 mm hex driver to remove the two shoulder screws (Fig. 18).
2. With the two shoulder screws removed, position the two halves of the corrosion link closer together, align the screw holes and insert the shoulder screws (Fig. 19).
3. Tighten the two shoulder screws with the supplied 2 mm hex driver (Fig. 20).

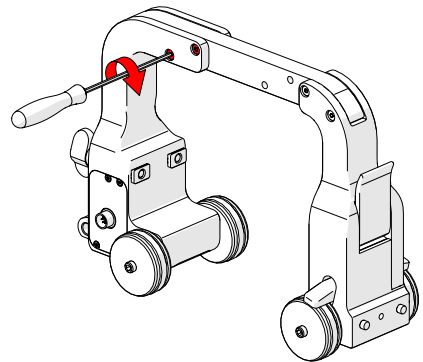

Fig. 20 - Tighten shoulder screws

4.4.2. Mounting a Frame Bar

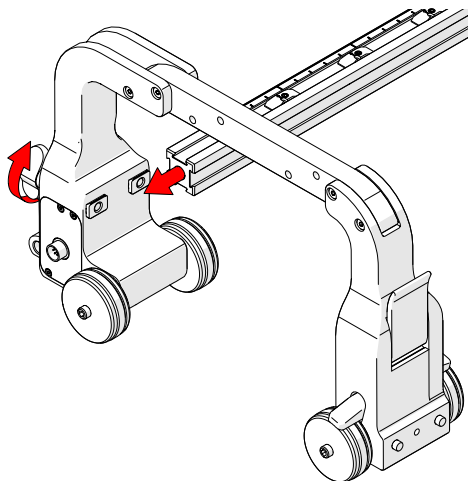

Fig. 21 - Loosen wing knobs

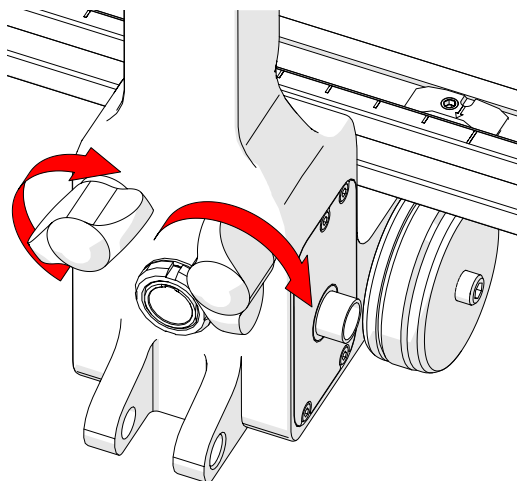

Fig. 22 - Tighten wing knobs

Ensure the two black wing knobs are loose (*Fig. 21*). Slide the frame bar along the dovetail nuts of the corrosion link (*Fig. 21*). When the frame bar is positioned where appropriate, tighten the two black wing knobs (*Fig. 22*).

4.4.3. Index Encoder Connection

The index encoder connection (*Fig. 23*) is located along the side of the corrosion link. The cable from the PPS encoder (see *Index Encoder on page 18*) connects to this point.

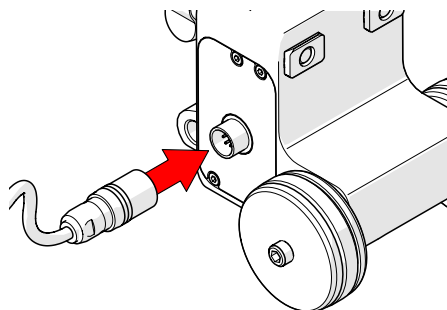

Fig. 23 - Index encoder connection

4.4.4. Encoder Connection

The encoder connection (*Fig. 24*) is located at the rear of the corrosion link. The encoder cable connects here. The opposite end of the encoder cable connects to the user's instrument.

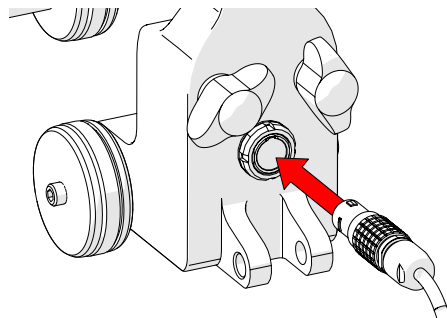

Fig. 24 - Encoder connection

4.4.5. Brake

The red lever on the corrosion and non-encoded corrosion links brake the system. Press the lever down to activate the brake.

TIP: When the brake is engaged, and the scanner is moved, this may loosen the wheels from the axle. Grip the wheel tightly and retighten the axle with the 3 mm hex driver.

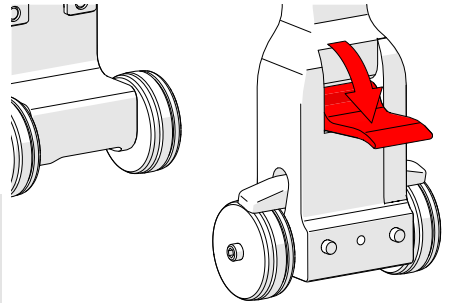

Fig. 25 - Brake

4.4.6. Wheel Removal/Installation

Tightly grip the wheel to be removed by hand. Loosen the wheel from the axle using the supplied 3 mm hex driver (Fig. 14).

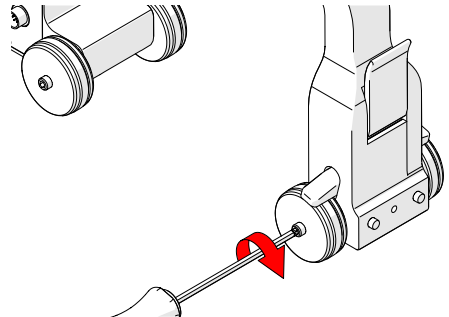

Fig. 26 - Wheel removal/installation



WARNING! MAGNETIC MATERIAL. The magnetic wheel kit produce a magnetic field which may cause failure or permanent damage to items such as watches, memory devices, CRT monitors, medical devices or other electronics. People with pacemakers or ICD's must stay at least 25 cm (10 in) away.

4.5. Carrier

With the use of a leadscrew, the carrier can move along the length of the frame bar.

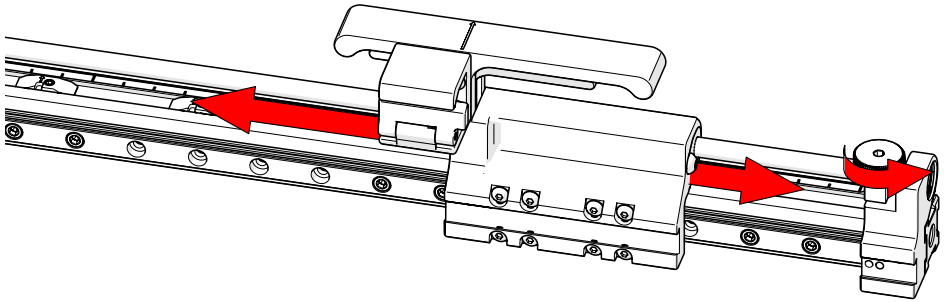

Fig. 27 - Loosen the leadscrew clamp knob

1. Loosen the leadscrew clamp knob (Fig. 27) to allow carrier movement along the frame bar.

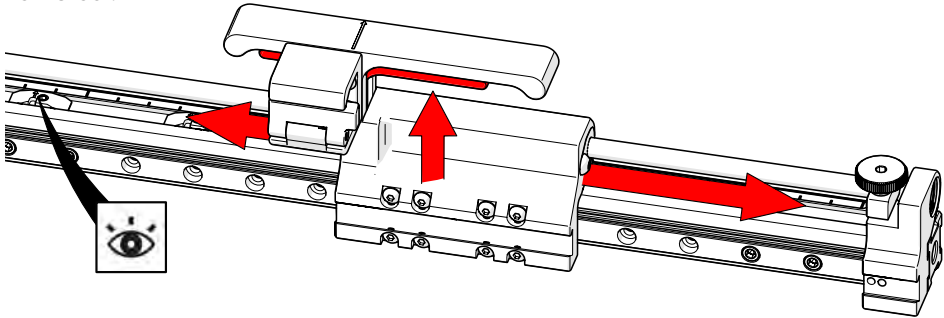

Fig. 28 - Carrier handle latch

2. Press the latch on the carrier handle to position the carrier to the next index location (Fig. 28).

4.5.1. Carrier Cable Clip

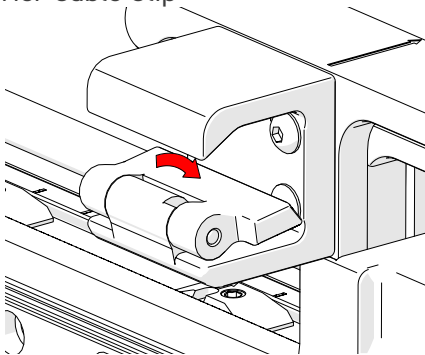

Fig. 29 - Carrier cable clip flap

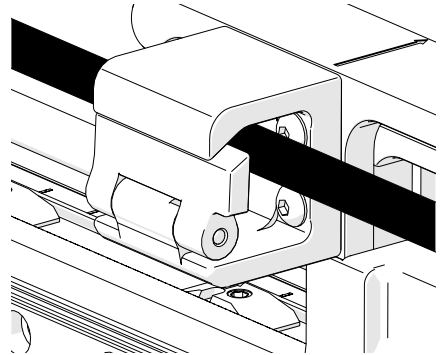

Fig. 30 - Carrier cable clip

1. Push the cable clip flap down (Fig. 29) to insert the necessary cables and hoses (Fig. 30).

4.5.2. Index Nuts

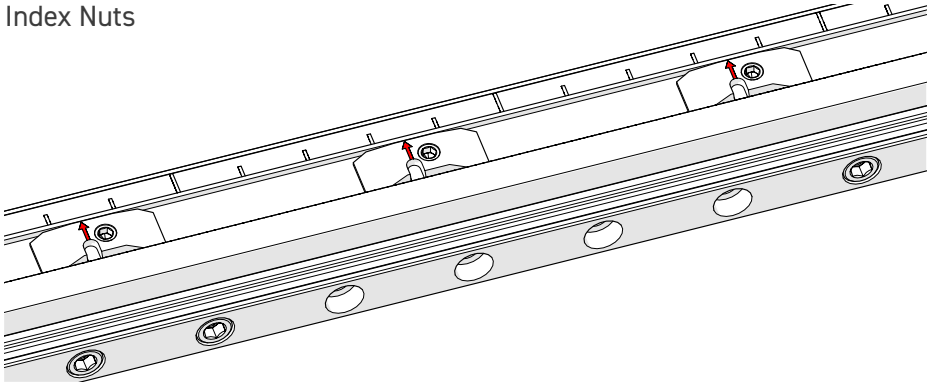

Fig. 31 - Index nuts

The index nuts (*Fig. 31*) along the frame bar offer index positions during scans.

The arrow found on the carrier's handle references the arrow on the corresponding index nut.

Align the arrows using the ruler to set the desired spacing.

NOTE: *The index nuts can be repositioned, and placement of the index nuts works in conjunction with typical probe specifications. Excessive adjustment of the index nuts is not recommended.*

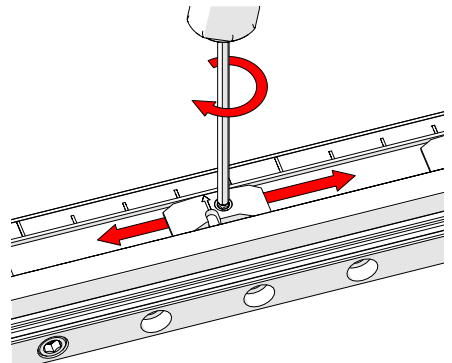

Fig. 32 - Position index nuts

4.6. Heavy Duty Vertical Probe Holder

- A Latch
- B Probe Holder Arm Adjustment Knob
- C Yoke
- D Probe Holder Arms
- E Pivot Buttons
- F Arm Clamp Screw
- G Probe Holder Adjustment Knob
- H Vertical Adjustment Knob

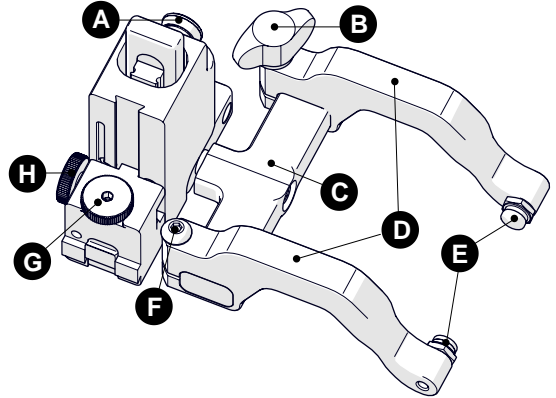

Fig. 33 - Heavy duty vertical probe holder

4.6.1. Probe Holder Setup

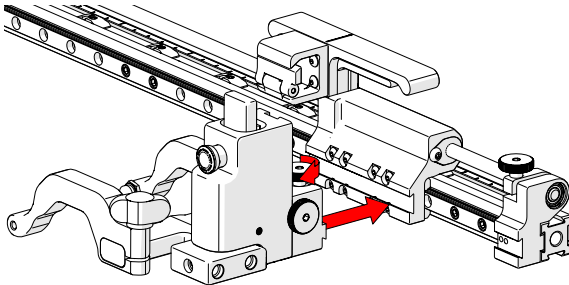

Fig. 34 - Mount probe holder to carrier

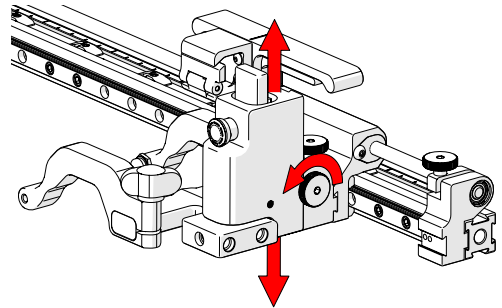

Fig. 35 - Vertical adjustment

1. Loosen the probe holder adjustment knob (Fig. 34) and mount the heavy duty vertical probe holder's dovetail jaw to the carrier.
2. The vertical adjustment knob (Fig. 35) allows height adjustment of the heavy duty vertical probe holder. This adjustment also controls the probe holder's spring tension.

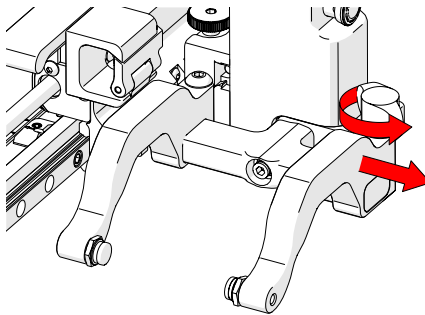

Fig. 36 - Remove outer arm

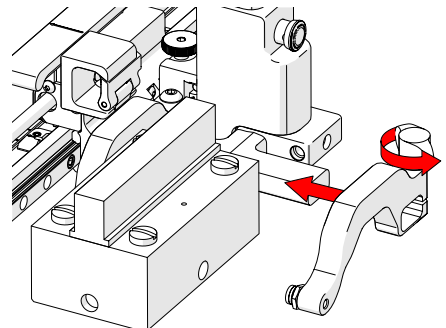

Fig. 37 - Adjust inner arm

3. Loosen the probe holder adjustment knob and remove the outer probe holder arm (Fig. 36).
4. Loosen the arm clamp screw (Fig. 37).
5. Place the wedge on the pivot button of the inner probe holder arm (Fig. 37).

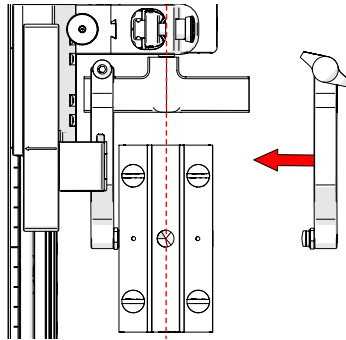

Fig. 38 - Remove outer arm

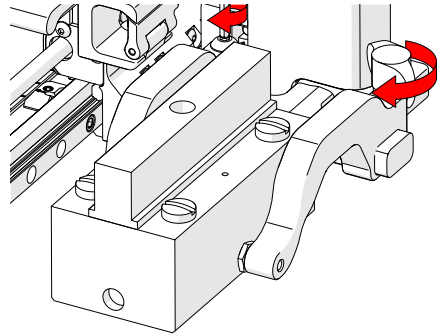

Fig. 39 - Pivot buttons

6. Align the middle of the wedge with the centre of the yoke (Fig. 38).
7. Tighten both the probe holder adjustment knob and the arm clamp screw (Fig. 39) while ensuring the wedge remains centred with the yoke.

4.6.2. Probe Holder Vertical Adjustment

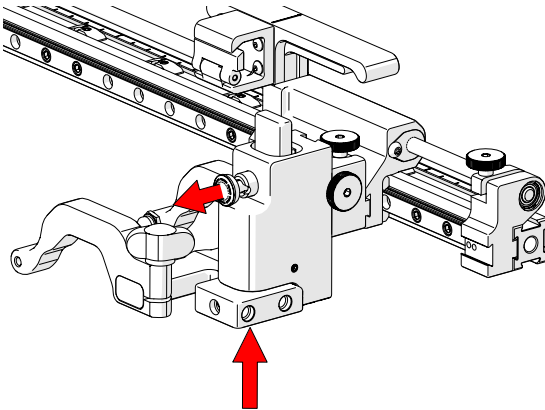

Fig. 40 - Press up and pull latch

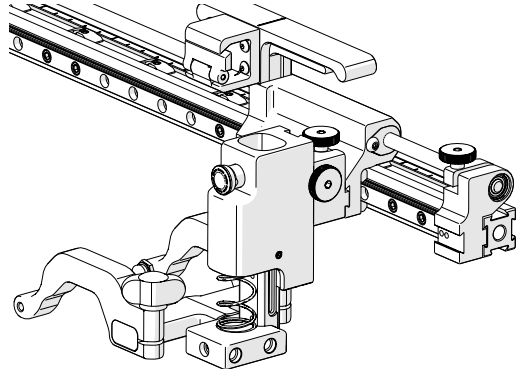

Fig. 41 - Lowered toward scan surface

1. Gently lift the heavy duty probe holder and simultaneously pull the latch (Fig. 40). This action will unlock the probe holder. Slowly lower the probe holder towards the scan surface (Fig. 41).

4.6.3. Probe Holder Left/Right Conversion

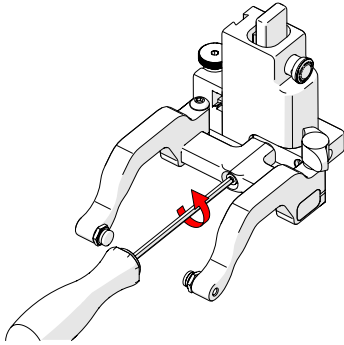

Fig. 42 - Remove yoke

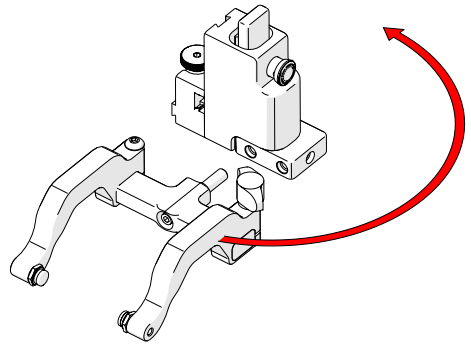

Fig. 43 - Orient to opposite side

1. Using the supplied 3 mm driver, unscrew the yoke (Fig. 42).
2. Position the yoke and arms on the opposite side of the probe holder (Fig. 43).

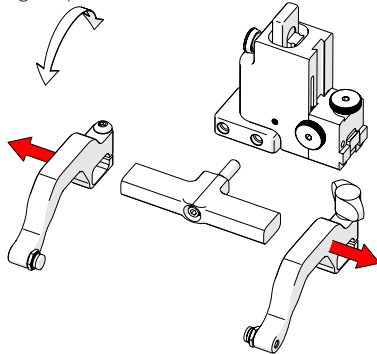

Fig. 44 - Remove probe holder arms

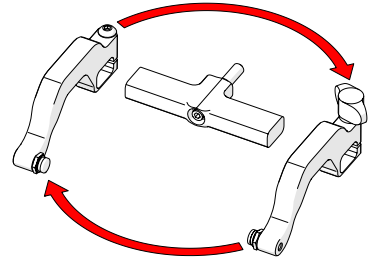

Fig. 45 - Reverse position around yoke

3. Loosen the arm clamp screw and the probe holder arm adjustment knob allowing the removal of the probe holder arms (Fig. 44).
4. Position the removed arms to the opposite sides of the yoke (Fig. 45).

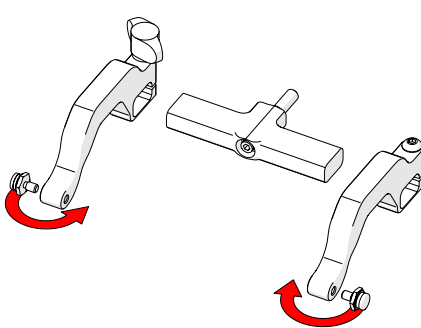

Fig. 46 - Position pivot buttons

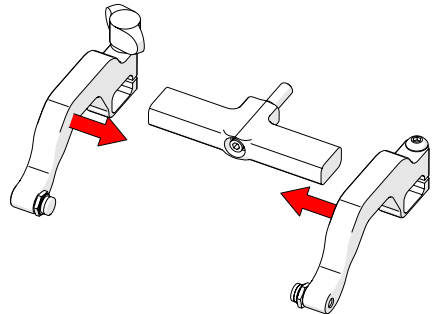

Fig. 47 - Remove outer arm

5. Position the pivot buttons to the inside of the probe holder arms (Fig. 46).
6. Place the probe holder arms on the yoke and tighten the arm clamp screw and probe holder adjustment knob (Fig. 47).
7. Use the supplied 3 mm driver to screw the yoke to the probe holder.

TIP: Position the yoke in the threaded hole closest to the frame bar when using a standard yoke length. Position the yoke in the threaded hole furthest from the frame bar when using a wide yoke length.

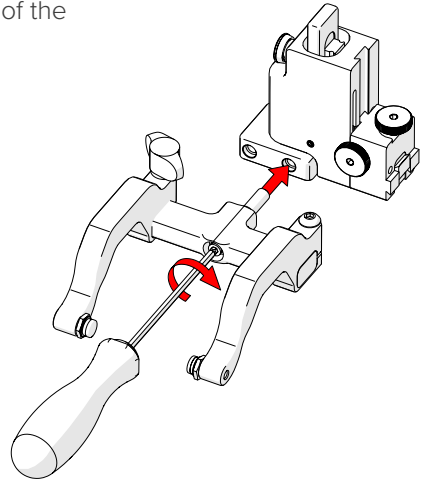

Fig. 48 - Screw into threaded hole

4.6.4. Yoke Substitution

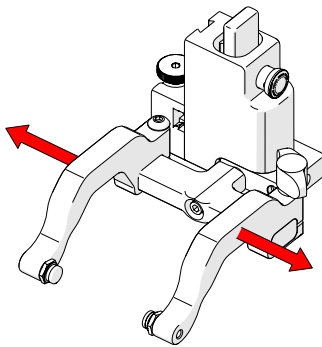

Fig. 50 - Remove probe holder arms

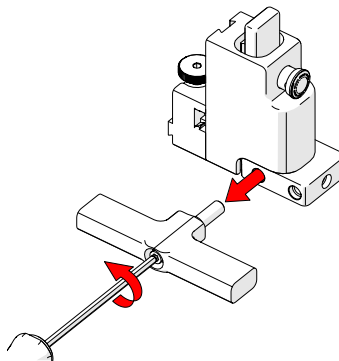

Fig. 51 - Remove yoke

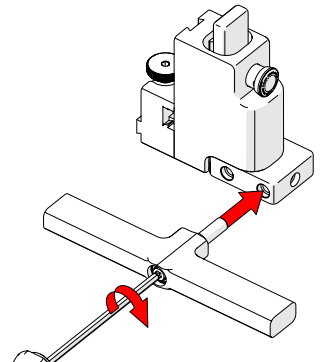

Fig. 52 - Screw into outer threaded hole

1. Loosen the arm clamp screw and the probe holder adjustment knob allowing the removal of the probe holder arms (Fig. 50).
2. Use the supplied 3 mm driver to unscrew the yoke (Fig. 51).
3. Choose an alternate size of yoke and screw the yoke to the outer probe holder hole (Fig. 52).
4. Place the probe holder arms on the yoke and tighten the arm clamp screw and probe holder adjustment screw (Fig. 49).

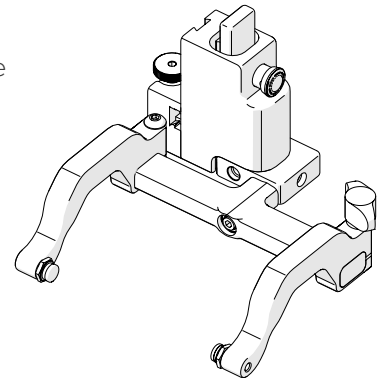

Fig. 49 - Alternate yoke size mounted

4.6.5. Probe Holder 90° Adjustment

1. Remove the yoke using the supplied 3 mm driver (Fig. 42).
2. Orient the yoke to the front of the probe holder and screw the yoke into the threaded hole provided (Fig. 53).

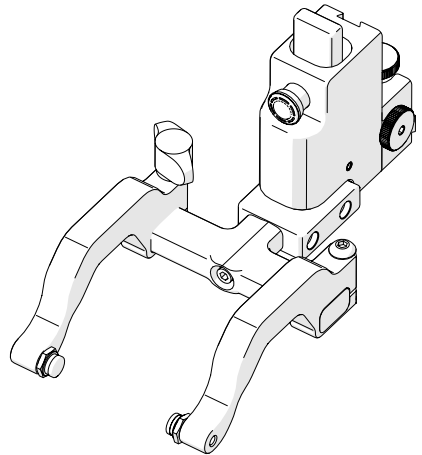

Fig. 53 - 90° probe holder positioning

4.7. Frame Bar with Ruler

Frame bars (Fig. 54) are used to mount probe holders, probe positioning systems and other accessories. The frame bar includes a ruler with 1 mm measurements.

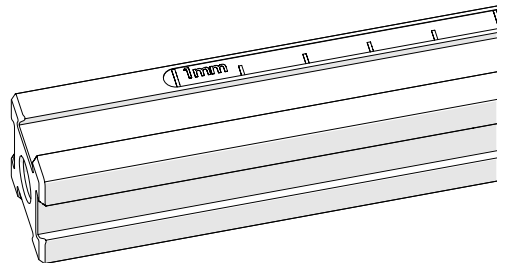

Fig. 54 - Frame bar

4.8. Pivot Buttons

Available in a variety of shapes and sizes, fitting various wedge dimensions.

Use the supplied 3/8 in wrench (Fig. 15) to remove and install pivot buttons (Fig. 55).

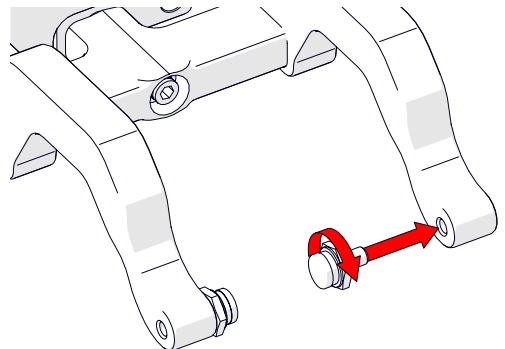

Fig. 55 - Pivot buttons

4.9. Index Encoder

The index encoder provides positional feedback perpendicular to the scan direction of travel.

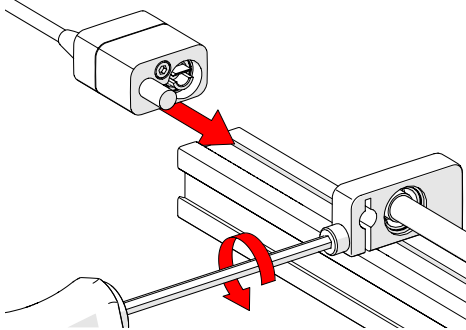

Fig. 56 - Loosen and slide post in place

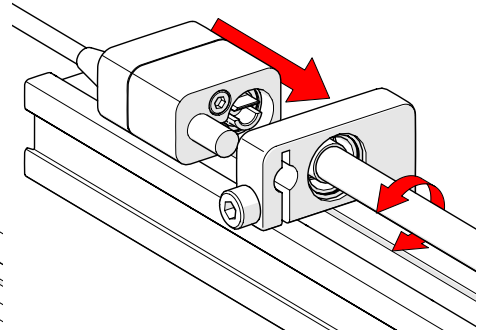

Fig. 57 - Align and mount post

1. To install the index encoder, loosen the clamp screw on the encoder with the supplied 3 mm hex driver (Fig. 56).
2. Insert the encoder post in the index encoder support bracket while aligning the leadscrew shaft with the encoder socket (Fig. 57).

TIP: You can rotate the leadscrew by hand to assist in the alignment of the encoder socket.

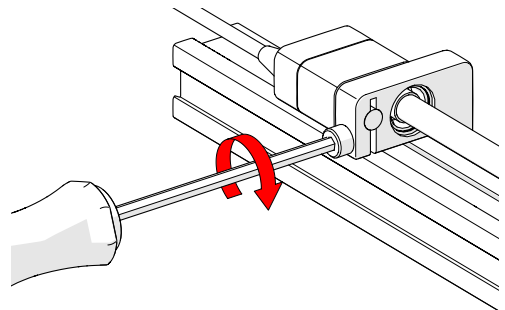

Fig. 58 - Tighten clamp screw

3. Tightening the 3 mm clamp screw on the index encoder support bracket (Fig. 58).
4. Plug the index encoder connector to the corrosion link (Fig. 59).

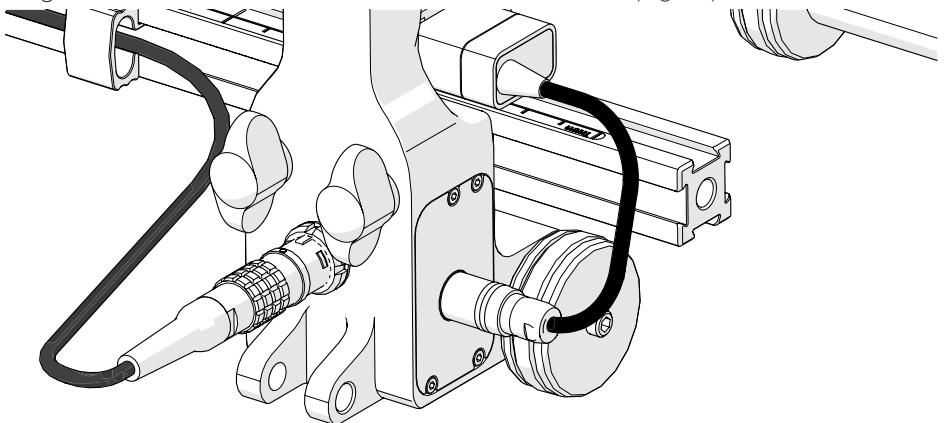

Fig. 59 - Connect index encoder to corrosion link

4.10. Cable Clips

Clips have been provided to assist with cable management. Pinch the clip and press it into the dovetail groove of the frame bar.

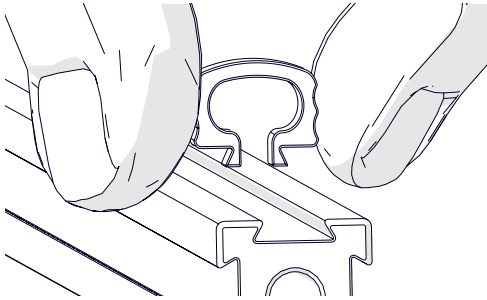

Fig. 60 - Pinch clip

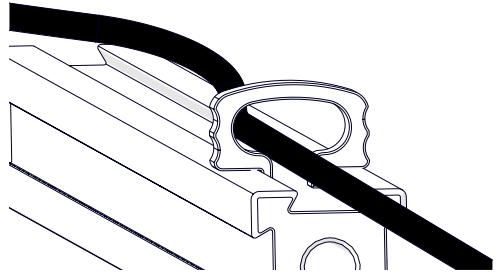

Fig. 61 - Route cables

4.11. Cable Management

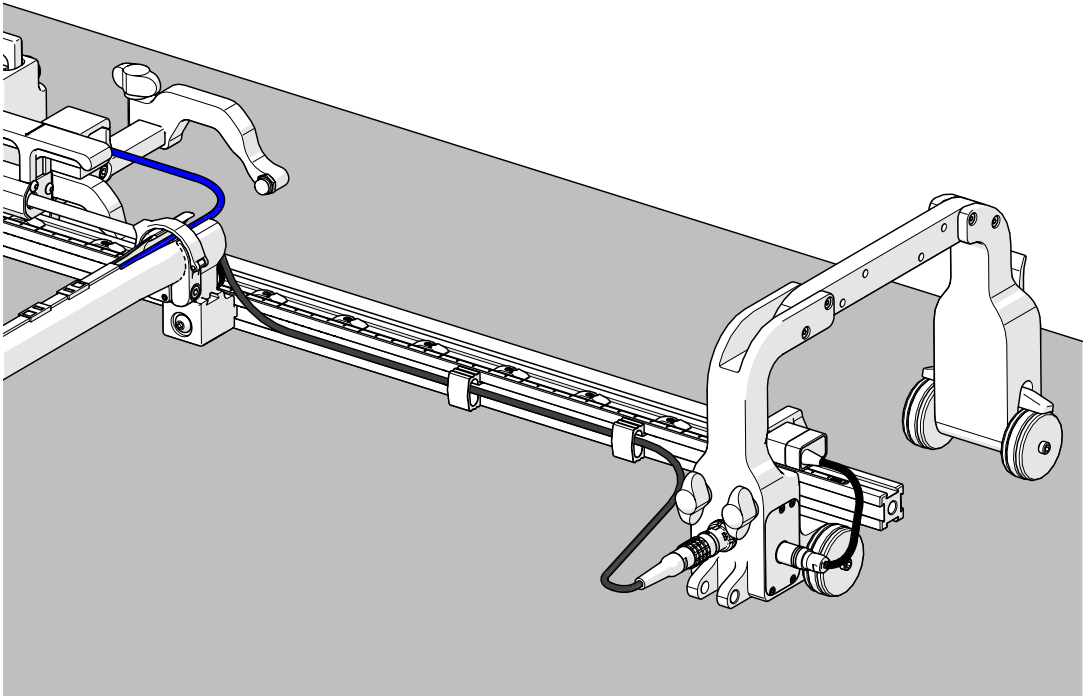

Fig. 62 - Cable management

TIP: When using cable management, ensure the dovetail link is placed 2nd in the chain behind the overhead adjustable link.

4.11.1. Cable Management Dovetail Mount

To attach the cable management, follow these steps:

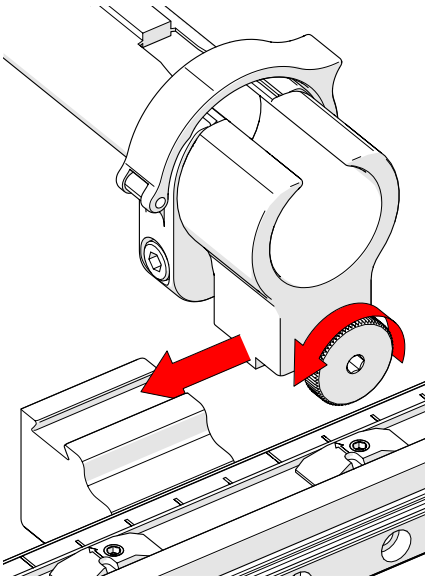

Fig. 63 - Loosen and slide on

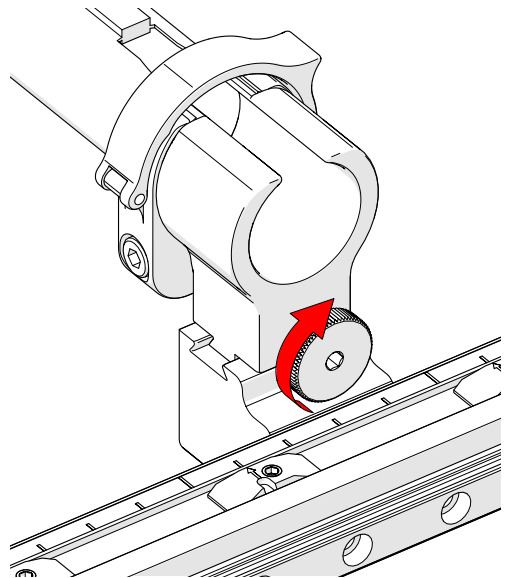

Fig. 64 - Tighten knob

1. Loosen the knob on the cable management dovetail mount. Slide the mount onto the dovetail link (Fig. 63).
2. Once centred on the dovetail link, tighten the cable management's dovetail mount knob (Fig. 64).

4.11.2. Cable Management Setup

The cable management is offered in a variety of lengths and provides a means of bundling and protecting cables and hoses that run to the scanner.

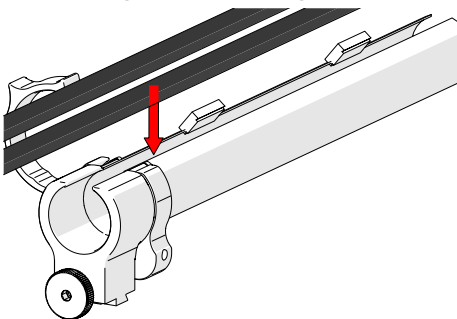

Fig. 65 - Insert cables and hoses

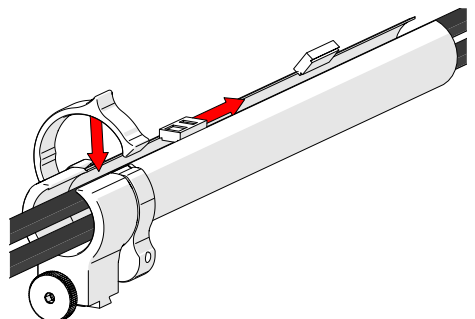

Fig. 66 - Zip up to close

1. Open the cable management and cable latch. Begin at the tube's dovetail mount and place the cabling in the tube (Fig. 65).

2. Follow the cable placement, zipping the tube closed and closing the cable management cable latch (Fig. 66).

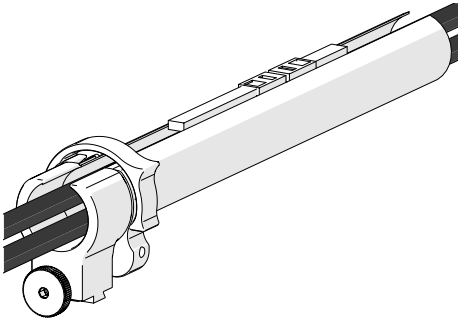

Fig. 67 - Zip opposite end

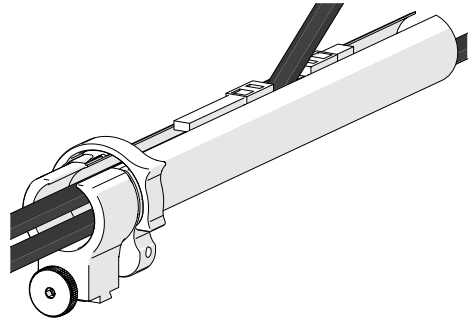

Fig. 68 - Flexibility

3. Once the cable is placed the entire length of the tube, bring the zipper from the tube's opposite end, meeting at any point in the middle (Fig. 67).
4. When necessary, the two zippers may be opened to allow cables to exit the tube anywhere between the ends (Fig. 68).

4.11.3. Clamp Setup

If the tube becomes disconnected from the cable management dovetail mount, follow these instructions to re-attach the tube and dovetail mount.

1. Loosen the clamp screw using the supplied 3 mm hex driver.
2. Slide the clamp around the tube first, then slide the tube around the outside of the cable management dovetail mount (Fig. 69). Align the zipper opening and the cable management dovetail mount opening.
3. Slide the clamp over the tube and cable management dovetail mount, pinching the tube in between (Fig. 70).
4. Tighten the clamp screw (Fig. 71).

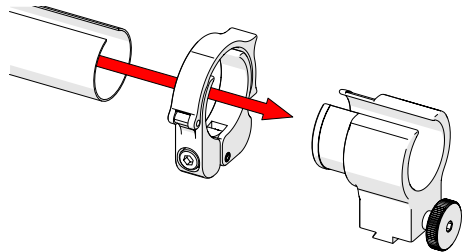

Fig. 69 - Slide tube around mount

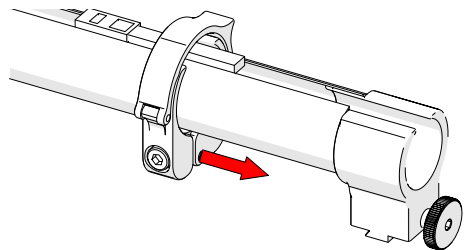

Fig. 70 - Slide clamp onto mount

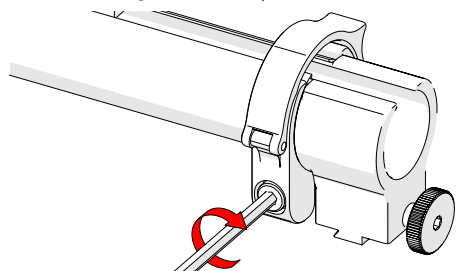

Fig. 71 - Tighten clamp screw

CONFIGURATION

5.1. Standard Configuration

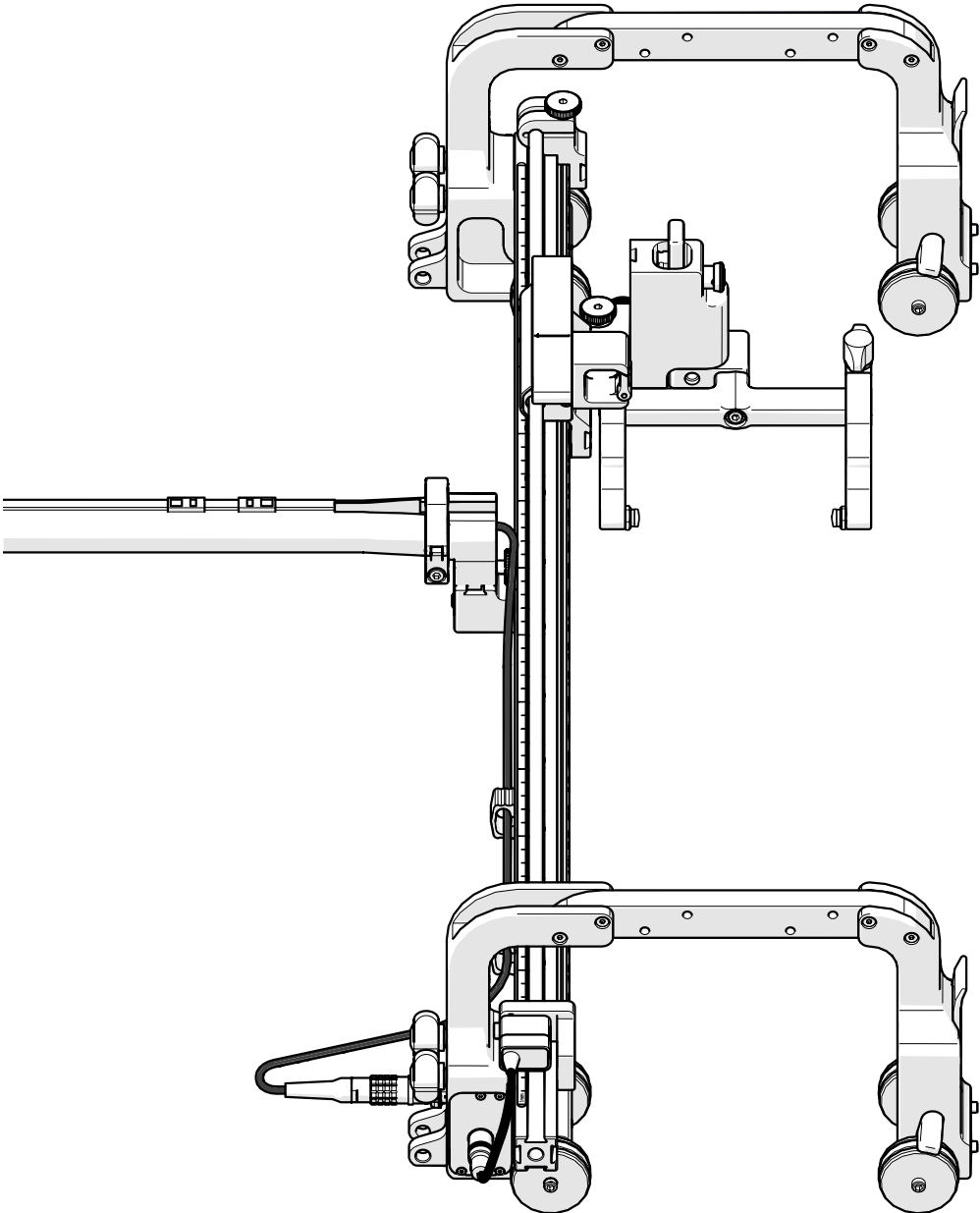

Fig. 72 - Standard configuration

OPERATION

6.1. Setup of a STIX on a Scanning Surface

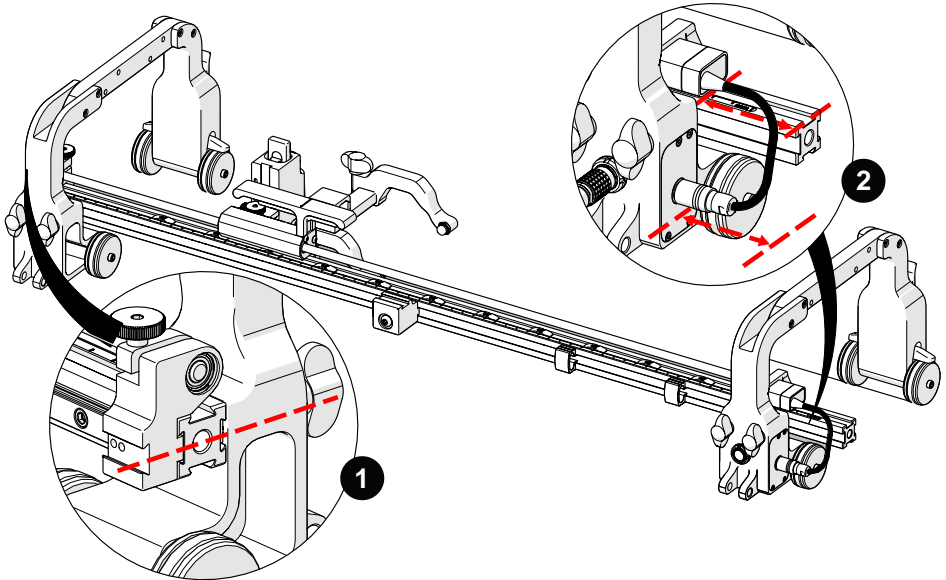

Fig. 73 - Frame bar offers protection for PPS encoder

1. Ensure the frame bar extends past the corrosion link (Fig. 73-2) on the encoder side. This will protect the index encoder connector. The non-encoded link can be flush with the frame bar (Fig. 73-1).

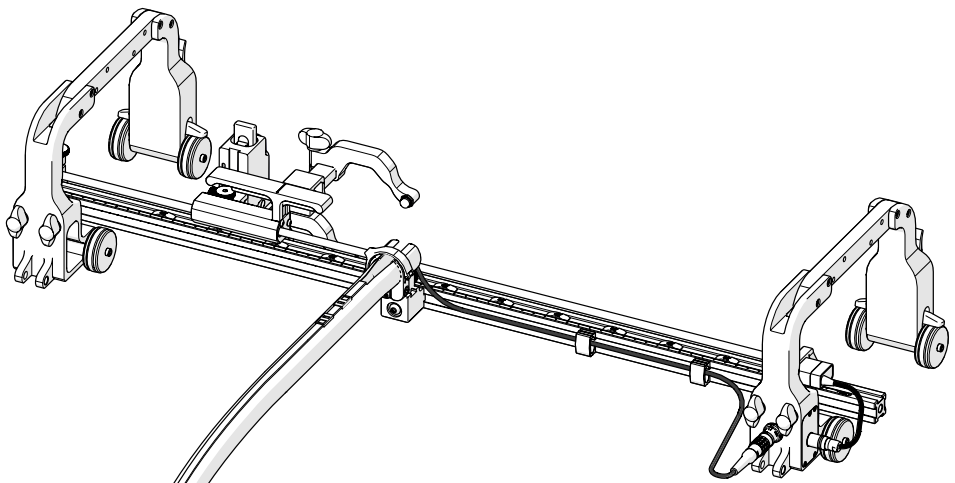

Fig. 74 - Route cabling

2. Plug in the encoder cable to the encoder connection (see *Encoder Connection* on page 9) and route the encoder cable through the cable management (see *Cable Management* on page 19) and cable clips (Fig. 74).

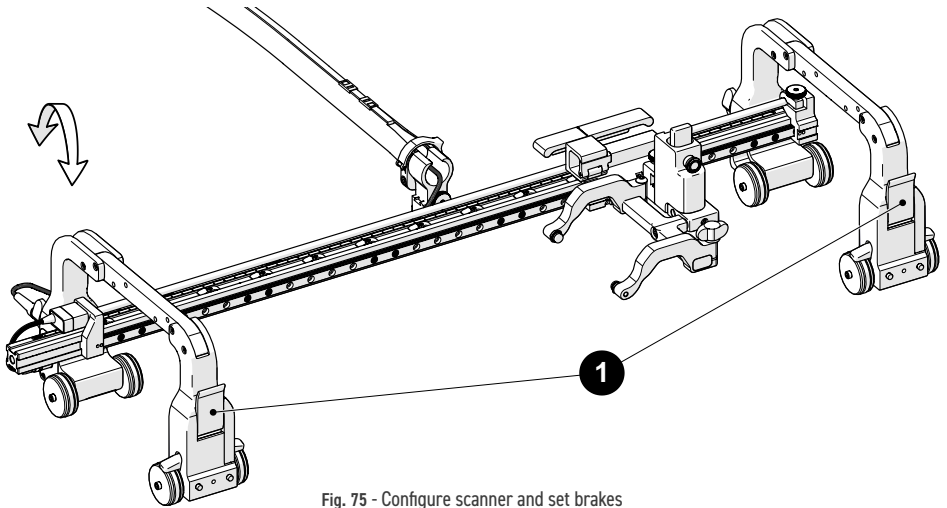

Fig. 75 - Configure scanner and set brakes

3. Install the wedge (see *Heavy Duty Vertical Probe Holder* on page 13) in the probe holder.
4. Ensure the brakes (Fig. 75-1) are activated (see *Brake* on page 10) on both corrosion links.

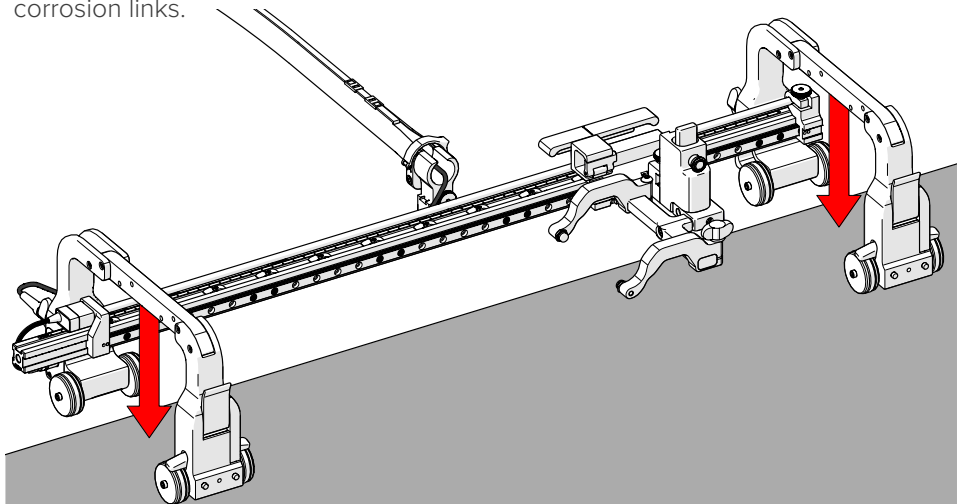

Fig. 76 - Place scanner on scan surface

5. Place the **STIX** on the scanning surface (Fig. 76).

TIP: Use caution when placing equipment on the scan surface. The magnetized wheels can cause the assembly to lurch towards the metal suddenly.

MAINTENANCE

General cleaning of components is important to keep your system working well. All components that have no wiring or cables are completely waterproof. Components can be washed with warm water, dish soap and a medium bristle brush.

Before using the scanner, ensure all connectors are free of water and moisture.

NOTE: *All components with wiring, cables or electrical connections are splashproof. However, these components are **NOT** submersible.*

NOTE: *Never use strong solvents or abrasive materials to clean your scanner components.*

TROUBLESHOOTING

Problem	Possible Cause	Solution
The encoder is not functioning.	The instrument is not set up correctly.	Refer to the instrument's documentation regarding proper setup.
	An issue with the encoder.	Contact Jireh Industries for repair (<i>see Jireh Industries Ltd. on page 1</i>).

8.1. Technical Support

For technical support, contact Jireh Industries (*see Jireh Industries Ltd. on page 1*).

SERVICE AND REPAIR



WARNING! DO NOT DISASSEMBLE. No user-serviceable parts. Disassembling any of the components in this product, beyond the instructions in this user manual, could void the regulatory certifications and/or effect the safety of the product.

SPARE PARTS

To order accessories or replacement parts for your **STIX** system.
(contact Jireh Industries Ltd. on page 1)

NOTE: These drawings are for parts order. This is not a list of kit contents.

10.1. Corrosion Scanner

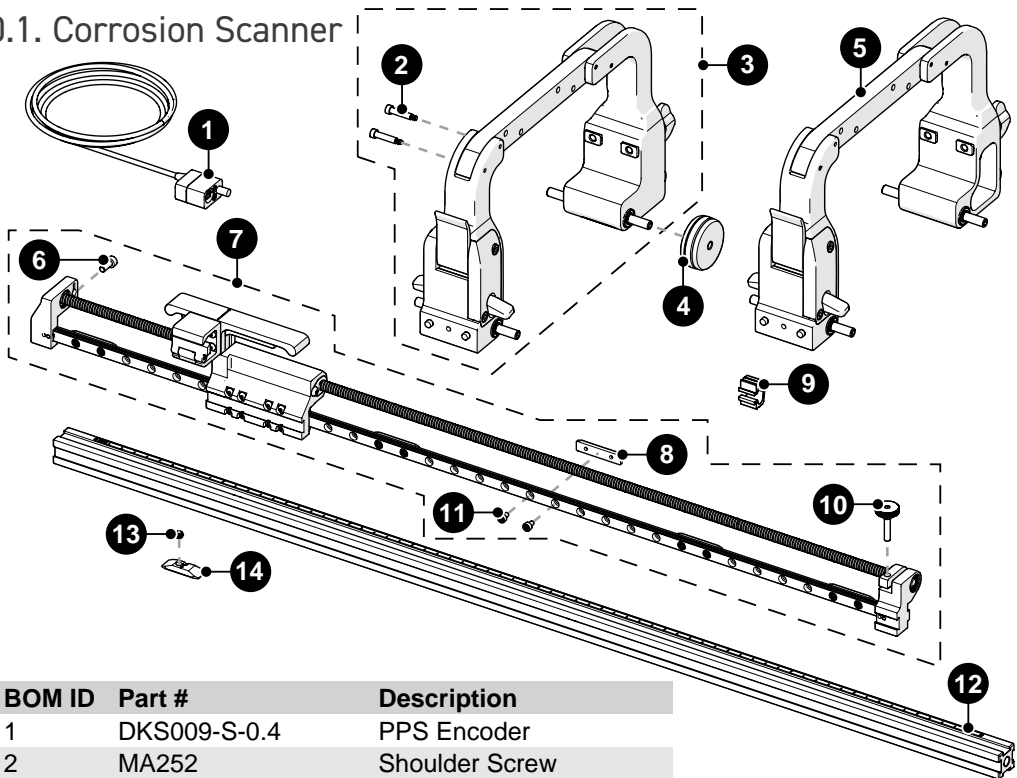

BOM ID	Part #	Description
1	DKS009-S-0.4	PPS Encoder
2	MA252	Shoulder Screw
3	CES064-C	Corrosion Link: Extended
4	BTS031	Magnetic Wheel
5	CES068-C	Non-Encoded Corrosion Link: Extended
6	MD050-010	SHCS, M4x0.7 X 8 mm, SST
7	DKS010-58	Corrosion Slider
8	DK0020	Dovetail Nut
9	BG0091	Cable Clip
10	PH0104	Leadscrew Clamp Knob
11	DK0019	Screw, M3X4.5 SHCS, 3 mm
12	BGS067	Frame Bar with Ruler, 75 cm
13	MA254	SHSS, M4 x 0.7 x 3 mm, flat point, SST
14	CE0116	Index Nut

Fig. 77 - STIX corrosion scanner parts

10.2. Kit Components

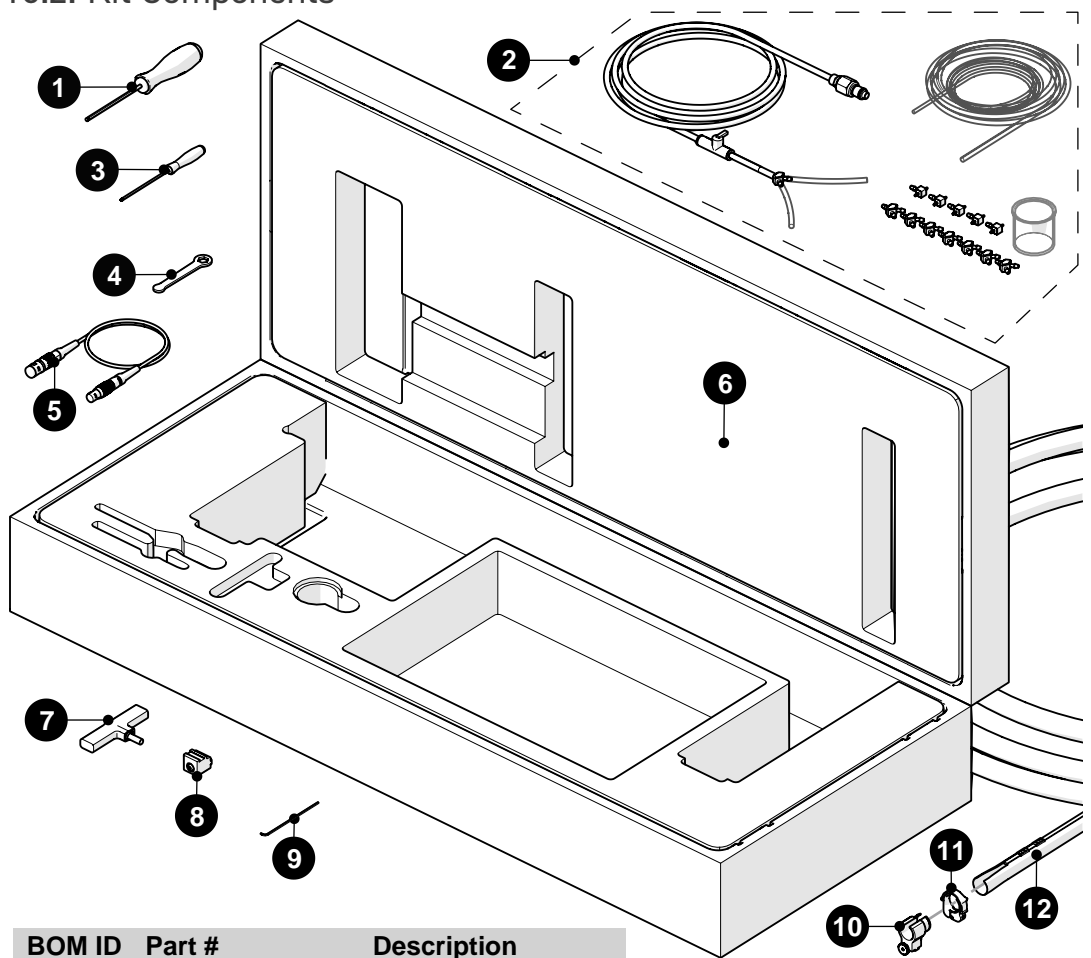

BOM ID	Part #	Description
1	EA414	3 mm Hex Driver
2	CMG007	Irrigation Kit, 2-4 Probe
3	EA476	2 mm Hex Driver
4	EA470	3/8 in Wrench
5	UMA026-_-07.5	Encoder Cable (see Encoder Connector Type)
6	BGA017	STIX Corrosion Case
7	See Heavy Duty Yoke Style	
8	BGS068	Dovetail Mount
9	CE0137	Short 2 mm Hex Wrench
10	CES067	Cable Management Mount
11	CES066	Cable Management Clamp
12	See Cable Management Length	

Fig. 78 - STIX kit components

10.2.1. Encoder Connector Type

Connector Type	Company/Instrument	Connector Type	Company/Instrument
B	Olympus OmniScan MX Zetec Topaz	G	Sonotron Isonic 25xx
C	Olympus Focus LT Zetec Z-Scan Eddyfi Ectane 2	U	Sonatest Veo / Prisma
E	Olympus OmniScan SX/MX2/X3 M2M MANTIS/GEKKO LEMO	V	Pragma PAUT
F	TD (<i>Technology Design</i>)	AD	Sonatest Veo / Prisma - Single Axis

NOTE: Additional encoder connector styles are available.
(contact Jireh Industries Ltd. on page 1)

10.2.3. Cable Management Length

Part #	Length
CX0226	7 m (22.9 ft)

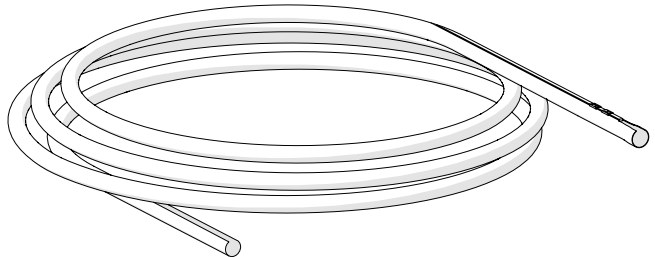

Fig. 79 - Cable management length

10.3. Accessories

10.3.1. Magnetic Wheel Kit

Part #	Description
BTG014	Magnetic Wheel Kit

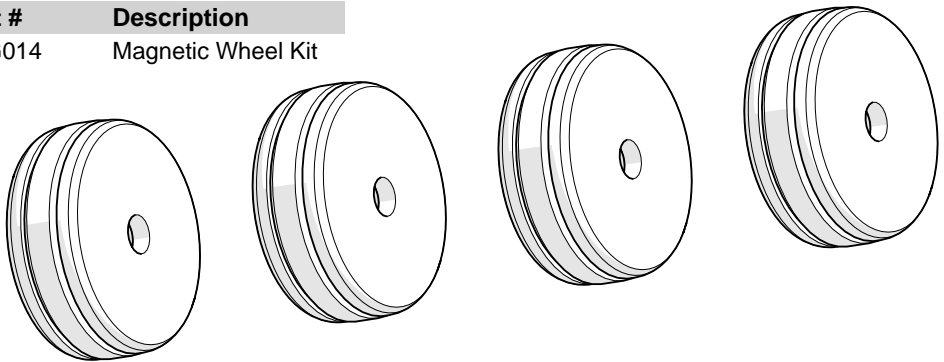

Fig. 80 - Magnetic wheel kit

10.3.2. Preamp Bracket

Part #	Description
CES029	Preamp Bracket
CES029-V	Preamp Bracket with Velcro

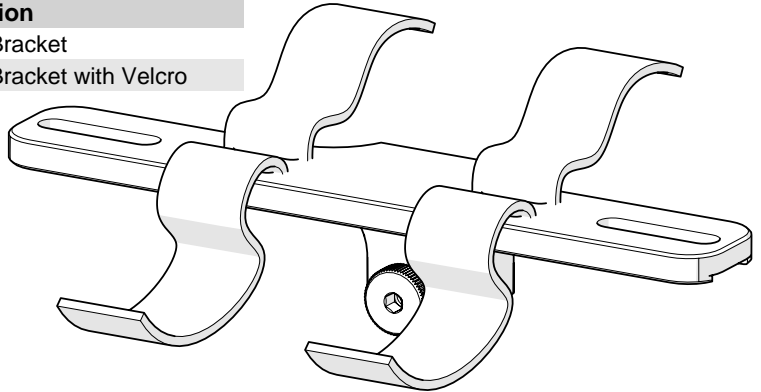

Fig. 81 - Preamp bracket

10.3.3. HydroFORM™ Cart

BOM ID	Part #	Description
1	CA119	Urethane Molded Wheel Bearing

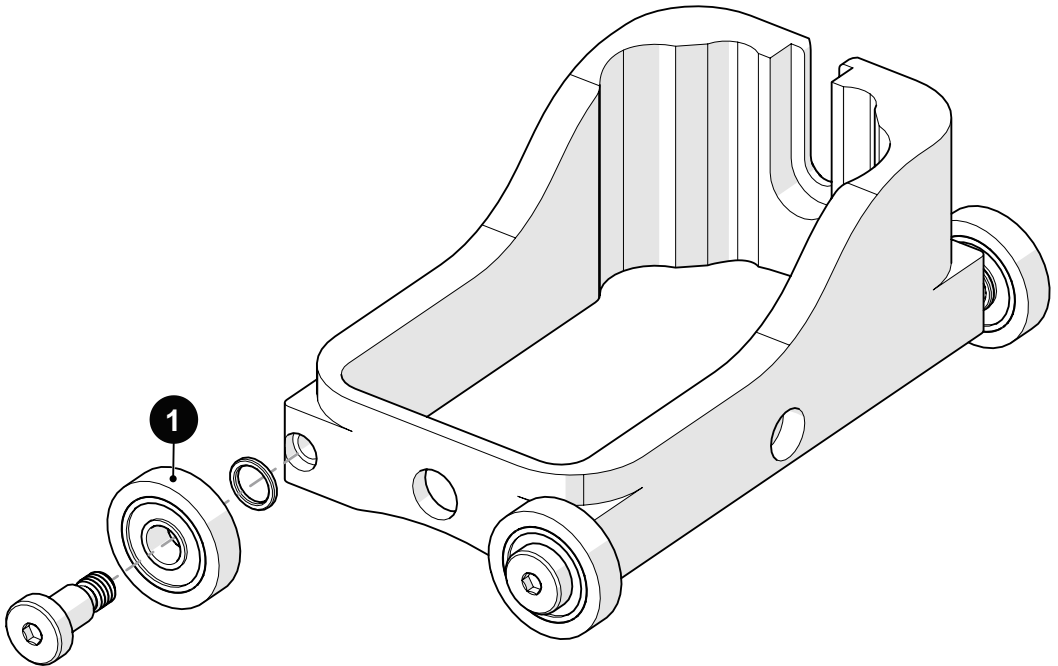
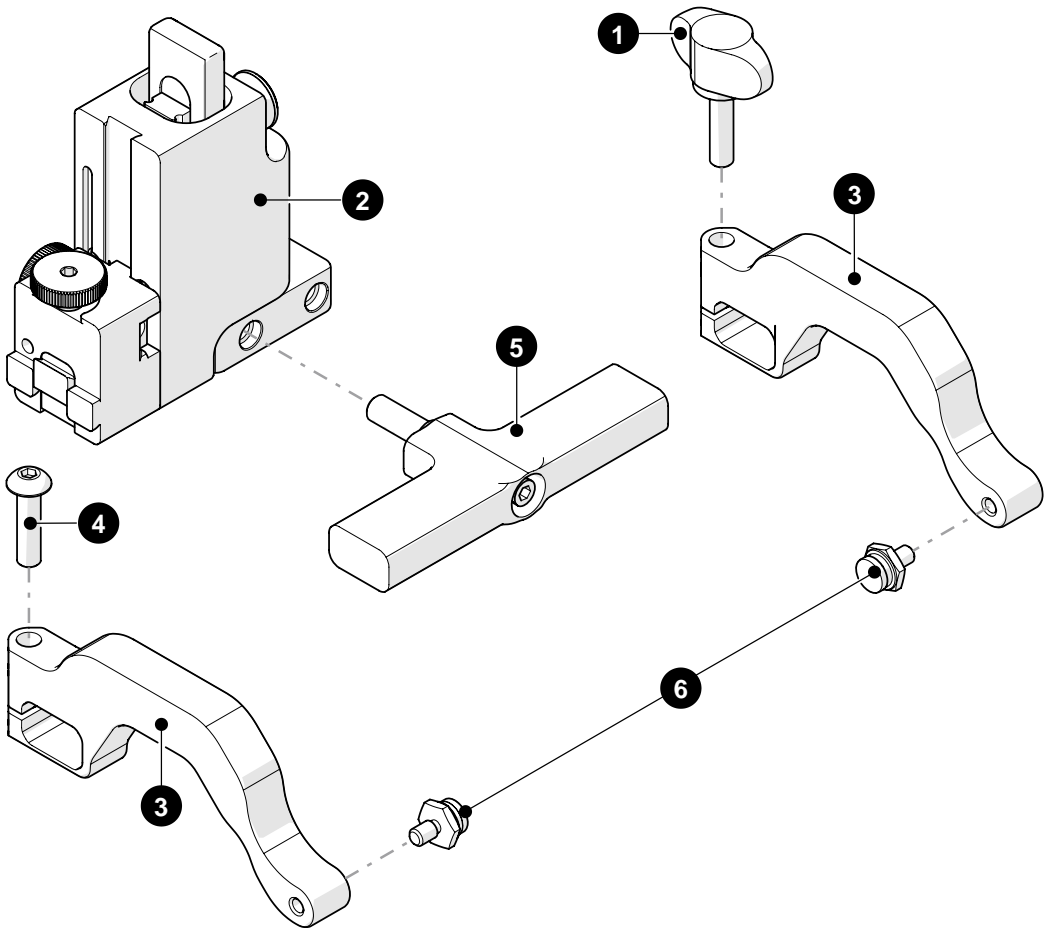

Fig. 82 - HydroFORM™ wheel replacement

10.4. Heavy Duty Vertical Probe Holder



BOM ID	Part #	Description
1	EA154	Probe Holder Arm Adjustment Knob
2	PHS049	Heavy Duty Probe Holder Subassembly
3	PH0165	Heavy Duty Probe Holder Arm, Standard, Drop
4	MD074-020	BHCS, M5 x 0.8 x 20 mm, SST
5	<i>See Heavy Duty Yoke Style</i>	
6	PH0011- <u> </u>	Pivot Button Style (<i>See Pivot Button Style</i>)

Fig. 83 - Heavy duty vertical probe holder

10.5. Probe Holder Components

10.5.1. Heavy Duty Yoke Style

Yoke Style	Part #	Length		Yoke Style	Part #	Length	
S Standard	PHS048	8.3 cm (3.26 in)		W Wide	PHS047	12.2 cm (4.79 in)	

Fig. 84 - Heavy duty probe holder yoke selection

10.5.2. Pivot Button Style











Pivot Hole Size	Wedge Type		Pivot Hole Size	Wedge Type	
01 8.0 mm (0.315 in)	Olympus PA		02 5.0 mm (0.197 in)	Olympus TOFD	
03 2.7 mm (0.106 in)	Sonatest DAAH PA		04 9.5 mm (0.375 in)	-	
06 3.0 mm (0.118 in)	-		07 2.3 mm (0.09 in)	-	
08 Conical Head	-		09 5 mm (0.197 in) Internal	Zetec PA/TOFD	
11 3 mm (0.118 in) Internal	-		14 4 mm (0.157 in)	-	

Fig. 85 - Probe holder button selection

NOTE: Additional probe holder pivot button types are available. (contact Jireh Industries Ltd. on page 1)

DISPOSAL

WEEE Directive

In accordance with European Directive on Waste Electrical and Electronic Equipment (WEEE), this symbol indicates that the product must not be disposed of as unsorted municipal waste, but should be collected separately. Refer to Jireh Industries for return and/or collection systems available in your country.

LIMITED WARRANTY

WARRANTY COVERAGE

Jireh Industries warranty obligations are limited to the terms set forth below: Jireh Industries Ltd. (“Jireh”) warrants this hardware product against defects in materials and workmanship for a period of THREE (3) YEARS from the original date of purchase. If a defect exists, at its option Jireh will (1) repair the product at no charge, using new or refurbished replacement parts, (2) exchange the product with a product that is new or which has been manufactured from new or serviceable used parts and is at least functionally equivalent to the original product, or (3) refund the purchase price of the product. A replacement product/part assumes the remaining warranty of the original product or ninety (90) days from the date of replacement or repair, whichever provides longer coverage for you. When a product or part is exchanged, any replacement item becomes your property and the replaced item becomes Jireh’s property. When a refund is given, your product becomes Jireh’s property.

OBTAINING WARRANTY SERVICE

To utilize Jireh’s warranty service you must ship the product, at your expense, to and from Jireh Industries. Before you deliver your product for warranty service you must phone Jireh and obtain an RMA number. This number will be used to process and track your product. Jireh is not responsible for any damage incurred during transit.

EXCLUSIONS AND LIMITATIONS

This Limited Warranty applies only to hardware products manufactured by or for Jireh Industries. This warranty does not apply: (a) to damage caused by accident, abuse, misuse, misapplication, or non-Jireh products; (b) to damage caused by service (including upgrades and expansions) performed by anyone who is not a Jireh Authorized Service Provider; (c) to a product or a part that has been modified without the written permission of Jireh.

Jireh Industries Ltd.
53158 Range Road 224
Ardrossan AB T8E 2K4
Canada
Phone: 780-922-4534
jireh.com

All brands are trademarks or registered trademarks of their respective owners and third-party entities.

Changes or modifications to this unit or accessories not expressly approved by the party responsible for compliance could void the user's authority to operate the equipment.

All specifications are subject to change without notice.

© 2015 - 2024 Jireh Industries Ltd.



Jireh Industries Ltd.
53158 Range Road 224
Ardrossan, Alberta
Canada
T8E 2K4

780-922-4534

jireh.com