



MICROBE

BT0211 Rev 00
Manual Magnetic Scanner

SAFETY WARNINGS / PRECAUTIONS

KEEP THIS MANUAL – DO NOT LOSE

THIS MANUAL IS PART OF THE **MICROBE** AND MUST BE RETAINED FOR THE LIFE OF THE PRODUCT. PASS ON TO SUBSEQUENT OWNERS.

Ensure any amendments are incorporated with this document.



WARNING! The **MICROBE** is designed for a specific use. Using the **MICROBE** outside of its intended use could cause damage to the product. Read and understand this manual before using.



WARNING! Can be harmful to pacemaker and ICD wearers. Stay at least 25 cm (10 in) away.



WARNING! Do **NOT** operate scanner in an explosive environment. Do **NOT** operate scanner in the presence of volatile substances.



WARNING! DO NOT DISASSEMBLE. No user-serviceable parts. Disassembling any of the components in this product, beyond the instructions in this user manual, could void the regulatory certifications and/or effect the safety of the product.



The **WEEE** symbol indicates that the product must not be disposed of as unsorted municipal waste, but should be collected separately.

(see *WEEE Directive* on page 45)

TABLE OF CONTENTS

1	Identification	1
	1.1. Product brand	1
	1.2. Manufacturer	1
	1.3. Compliance Declarations	1
	1.3.1. ISED Emissions Compliance (Canada).....	1
	1.3.2. FCC Suppliers Declaration of Conformity (United States).....	1
	1.3.3. European Union CE Declarations	2
	1.3.4. UKCA Declarations	2
2	Product Specifications	3
	2.1. Intended Use	3
	2.1.1. Operating Limits	3
	2.1.2. Operating Environment	3
	2.2. Dimensions and Weight	4
	2.4. Environmental Sealing	5
	2.5. Performance Specifications	5
3	Definitions	6
	3.1. Definition of Symbols	6
	3.2. Definitions of Terms	6
4	System components	7
	4.1. Base System Components	7
	4.1.1. MICROBE Cart	7
	4.1.2. J100 Encoder Cable	7
	4.1.3. Frame Bar	7
	4.1.4. MICROBE Rear Pivot	8
	4.1.5. Magnetic Wheel	8
	4.1.6. Slip Joint Probe Holder	8
	4.1.7. Irrigation Kit	9
	4.1.8. Tools	9

4.1.9. Case	9
4.2. Compatible Components	10
4.2.1. Battery Powered Optical Guide	10
4.2.2. Preamp Bracket	10
4.2.3. Encoder Adapter	10
4.3. Tools	11
4.3.1. Included tools	11
4.3.2. Optional tools	11

5

Preparation for Use 12

5.1. Configurations	12
5.1.1. One Probe Cantilever	12
5.1.2. Two Probe	12
5.1.3. Two Probe Cantilever	13
5.1.4. Four Probe	13
5.2. Cart Setup And Adjustment	14
5.2.1. Cart Handle	14
5.2.2. Brake Lever	14
5.2.3. Wheel Removal/Installation	15
5.2.4. Encoder Cable Connector	16
5.2.5. Y-Axis Connector	16
5.2.6. Pivot Nose	16
5.2.6.1. Pivot Nose Alignment	18
5.2.7. Rear Pivot Installation	19
5.2.8. Cable Management	20
5.2.9. Anchor Point	21
5.3. Pivot Buttons	21
5.4. Slip Joint Probe Holder	22
5.4.1. Probe Holder Setup	22
5.4.2. Probe Holder Adjustment	24
5.4.3. Probe Holder Force Adjustment	24
5.4.4. Slip Joint Probe Holder Left/Right Conversion	26
5.5. Magnetic Wheel Kit	28
5.6. Cable Clips	29
5.7. Preamp Bracket	30
5.7.1. Mounting Preamp Bracket	30
5.7.2. Attaching Preamp with Screws	30
5.7.3. Attaching Preamp with Velcro Strap.....	31

6

Operation 32

	6.1. MICROBE Setup on a Scanning Surface	32
7	Maintenance	36
8	Troubleshooting	37
	8.1. Technical Support	37
9	Service and Repair	38
10	Spare Parts	39
	10.1. MICROBE Cart	39
	10.2. Kit Components	40
	10.2.1. Encoder Connector Type	41
	10.3. Probe Holders	42
	10.3.1. Slip Joint Probe Holder Parts	42
	10.4. Probe Holder Components	43
	10.4.1. Arm Style	43
	10.4.2. Yoke Style	43
	10.4.3. Swing Arm Style	43
	10.4.4. Pivot Button Style	43
	10.5. Variable Components	44
	10.5.1. Frame Bars	44
	10.6. Accessories	44
	10.6.1. Magnetic Wheel Kit	44
	10.6.2. Preamp Bracket	44
11	Disposal	45
12	Limited Warranty	46

IDENTIFICATION

1.1. Product brand

This user manual describes the proper safety precautions, setup and use of the **MICROBE** magnetic scanner.

1.2. Manufacturer

Distributor:

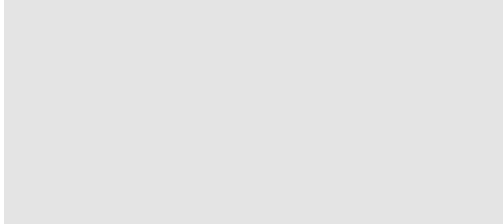

Manufacturer:

Jireh Industries Ltd.
53158 Range Road 224
Ardrossan, Alberta, Canada
T8E 2K4
Phone: 780.922.4534
jireh.com

1.3. Compliance Declarations

1.3.1. ISED Emissions Compliance (Canada)

CAN ICES-003(A) / NMB-003(A)

This Class A digital apparatus complies with Canadian ICES-003.

Cet appareil numérique de la classe A est conforme à la norme NMB-003 du Canada.

1.3.2. FCC Suppliers Declaration of Conformity (United States)

This device complies with Part 15 of the FCC Rules. Operation is subject to the following two conditions: (1) this device may not cause harmful interference, and (2) this device must accept any interference received, including interference that may cause undesired operation.

This equipment has been tested and found to comply with the limits for a Class A digital device, pursuant to part 15 of the FCC Rules. These limits are designed to provide reasonable protection against harmful interference when the equipment is operated in a commercial environment. This equipment generates, uses, and can radiate radio frequency energy and, if not installed and used in accordance with the instruction manual, may cause harmful interference to radio communications. Operation of this equipment in a residential area is likely to cause harmful interference in which case the user will be required to correct the interference at his own expense.

RESPONSIBLE PARTY NAME:	Jireh Industries
ADDRESS:	2955 S Sam Houston Pkwy E Suite 300 Houston, Texas United States 77047
TELEPHONE:	832-564-0626

1.3.3. European Union CE Declarations

Jireh Industries hereby declares that the **MICROBE** product complies with the essential requirements and other relevant provisions of the following European Union directives:



- 2014/30/EU EMC Directive
- 2014/35/EU Low Voltage Directive
- 2012/19/EU Directive on Waste Electrical and Electronic Equipment
- 2011/65/EU Directive on Restriction of Hazardous Substances (RoHS)

1.3.4. UKCA Declarations

Jireh Industries hereby declares that the **MICROBE** product complies with the essential requirements and other relevant provisions of the following UK directives.



Title	Edition/Date of Issue
Electromagnetic Compatibility Regulations	2016
Electrical Equipment (Safety) Regulations	2016
Waste Electrical and Electronic Equipment Regulations	2013
Restriction of the Use of Certain Hazardous Substances in Electrical and Electronic Equipment Regulations	2012

PRODUCT SPECIFICATIONS

2.1. Intended Use

The **MICROBE** is a handheld scanner with a built-in encoder and magnetic wheels. It is designed to translate phased array and/or TOFD probes around ferrous piping and vessels.

2.1.1. Operating Limits

Category	Parameter	Specification
Inspection Surface	2 probe, circumferential OD pipe/tube	
	Minimum	3.8 cm (1.5 in)
	Maximum	Flat
	4 probe, circumferential OD pipe/tube	
	Minimum	7.6 cm (3 in)
	Maximum	Flat
Longitudinal OD pipe/tube	Minimum	7.6 cm (3.0 in)
	Maximum	Flat
	Circumferential ID pipe/tube	
	Minimum	152.4 cm (60 in)

2.1.2. Operating Environment

The **MICROBE** is designed for use in industrial environments that are between -20°C (-4°F) and 50°C (122°F).

2.2. Dimensions and Weight

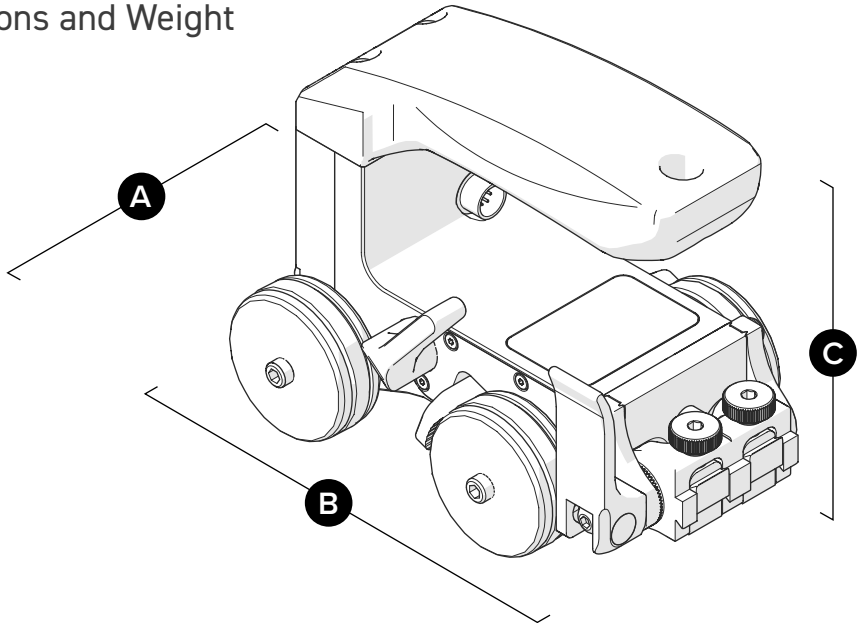

Fig. 1 - Cart with single wheel, dimensions

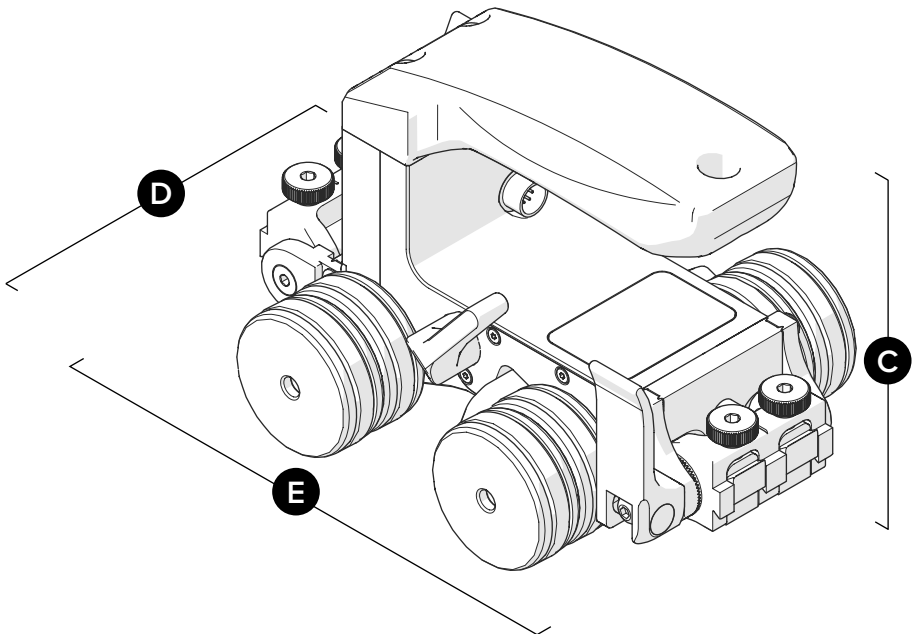

Fig. 2 - Cart with double wheels and MICROBE rear pivot, dimensions

A Cart width (<i>4 magnetic wheels</i>)	8 cm	3.2 in
B Cart depth	13.2 cm	5.2 in
C Cart height	9.8 cm	3.8 in
D Cart width (<i>8 magnetic wheels & MICROBE rear pivot</i>)	10 cm	3.9 in
E Cart depth	14.4 cm	5.7 in
Encoder cable length (<i>standard kit</i>):	5 m (<i>16.4 in</i>)	
Cart weight:	0.78 kg (<i>1.7 lb</i>)*	

2.4. Environmental Sealing

Dust-tight, watertight (*not submersible*).

2.5. Performance Specifications

X-Axis encoder resolution	66.0 counts/mm (<i>1676.3 counts/inch</i>)
---------------------------	----------------------------------------------

DEFINITIONS

3.1. Definition of Symbols

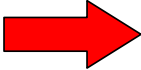
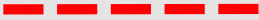
	Instructions to 'look here' or to 'see this part.'
	Denotes movement. Instructing users to carry out an action in a specified direction.
	Indicates alignment axis and can also display the insertion or movement of parts.

3.2. Definitions of Terms

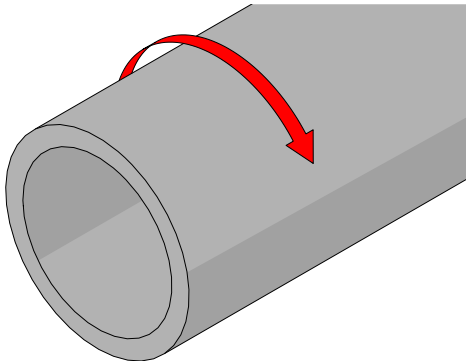

Fig. 3 - Circumferential scanning

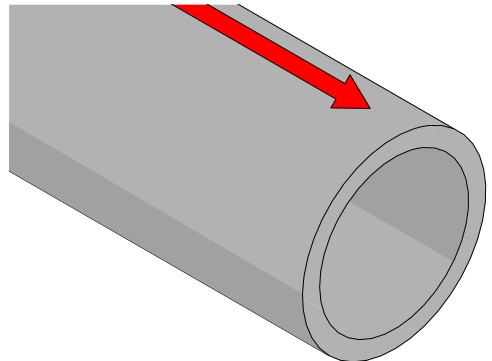

Fig. 4 - Longitudinal scanning

Circumferential	Direction of scan travel is around the circumference of the pipe/tube (Fig. 3).
Longitudinal	Direction of scan travel is lengthwise of the pipe/tube (Fig. 4)

SYSTEM COMPONENTS

4.1. Base System Components

4.1.1. MICROBE Cart BTA015

The cart body houses the positional encoder and provides a pivot nose for mounting frame bars. The encoder connector is located at the rear of the cart, while the Y-axis connector is found under the handle (Fig. 5).

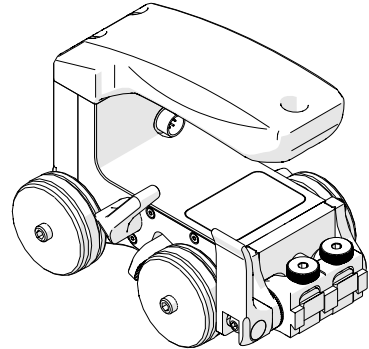

Fig. 5 - MICROBE cart

4.1.2. J100 Encoder Cable UMA026-

The encoder cable connects the **MICROBE** cart to the user's instrument. (Fig. 6).

Various encoder cable styles are available for various instruments.

NOTE: *Inspect the cable and connectors for damage before use. When damage is evident, the cable must **NOT** be used.*

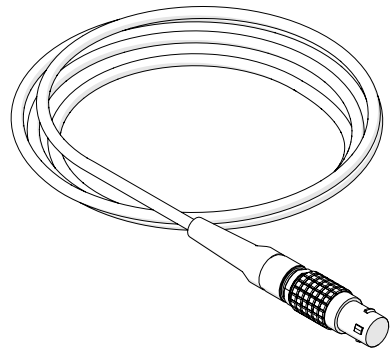

Fig. 6 - J100 encoder cable

4.1.3. Frame Bar BG0038-

Frame bars use dovetail grooves into which probe holders and accessories may be attached (Fig. 7).

Available in various lengths.

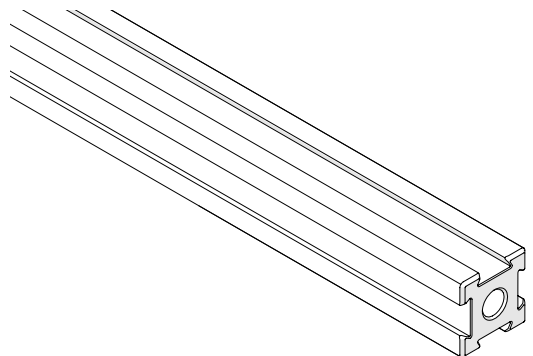

Fig. 7 - Frame bar

4.1.4. MICROBE Rear Pivot BTS042

The MICROBE Rear Pivot is mounted at the rear of the cart as an attachment point for standard frame bars carrying probe holders and other components. (Fig. 8).

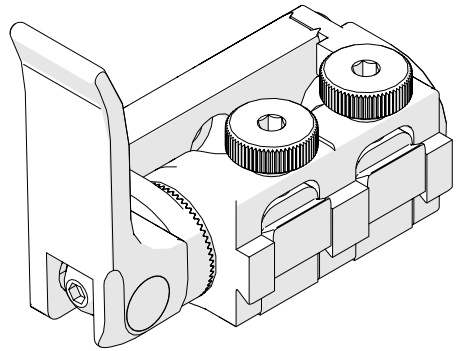

Fig. 8 - MICROBE rear pivot

4.1.5. Magnetic Wheel BTS031

Magnetic wheels allow the scanner to adhere to ferrous materials.

Magnetic wheels can be added to the MICROBE cart to increase its magnetic attraction (see *Magnetic Wheel Kit* on page 28).

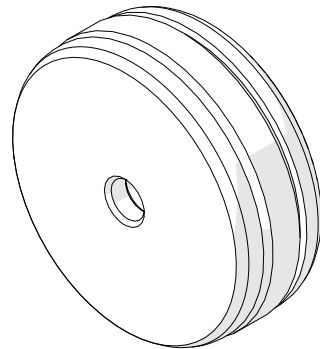

Fig. 9 - Magnetic wheel

4.1.6. Slip Joint Probe Holder PHA012-

The low profile design of the slip joint probe holder requires minimal radial clearance. The slip joint probe holder is designed to carry many different types of probes and wedges. It is available with various types of yokes, arms and pivot buttons (Fig. 10).

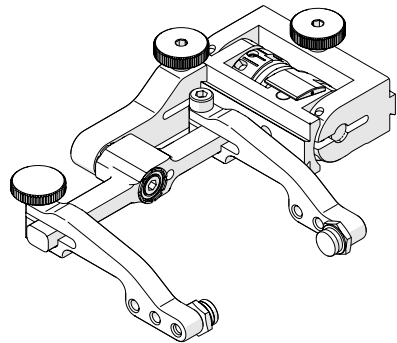

Fig. 10 - Slip joint probe holder

4.1.7. Irrigation Kit CMG007

The irrigation kit provides a variety of hoses, fittings, connectors and splitters commonly used during non-destructive inspection (*Fig. 11*).

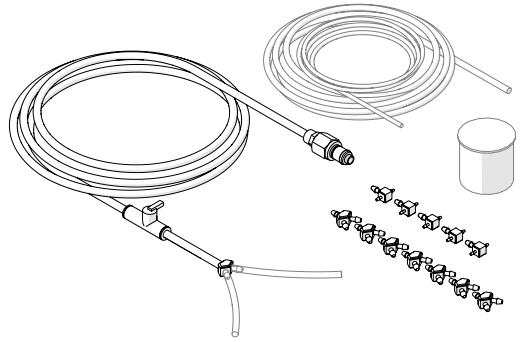

Fig. 11 - Irrigation kit

4.1.8. Tools

Several tools are included for various scanner and accessory adjustment.

4.1.9. Case

The system is provided with a rugged carrying case.

4.2. Compatible Components

4.2.1. Battery Powered Optical Guide CXS080

The battery powered optical guide (Fig. 12) provides a red reference line useful for guiding scanners along a given path (i.e. a weld).

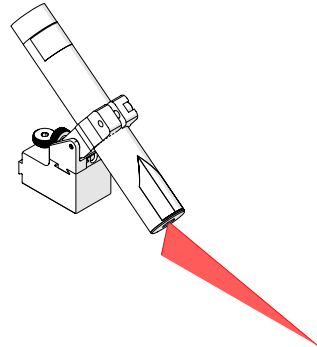

Fig. 12 - Battery powered optical guide

4.2.2. Preamp Bracket CES029-

The preamp mounts to any dovetail groove. It is compatible with most standard preamps.

An option to include velcro straps for holding a preamp is also available. (Fig. 13).

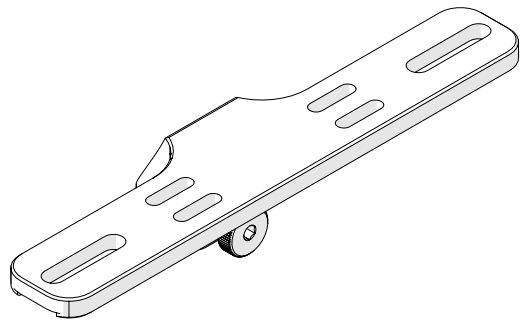

Fig. 13 - Preamp bracket

4.2.3. Encoder Adapter UMA010-

Adapt a scanner's existing encoder connector to a different encoder style (Fig. 14).

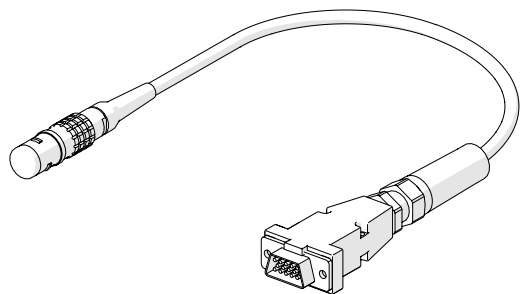

Fig. 14 - Encoder adapter

4.3. Tools

4.3.1. Included tools

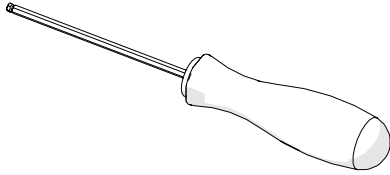

Fig. 15 - 3 mm hex driver

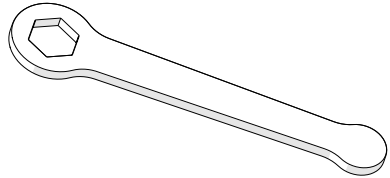

Fig. 16 - 3/8 in wrench

The 3 mm hex driver (*Fig. 15*) is sufficient for all typical operations and adjustments of the **MICROBE**.

The 3/8 in wrench (*Fig. 16*) removes, and installs pivot buttons on the probe holders.

4.3.2. Optional tools

Some specialized adjustments require tools that are not included in this kit.

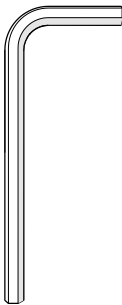

Fig. 17 - 2 mm
hex wrench

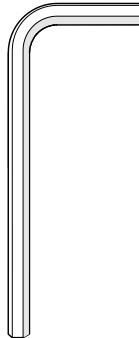

Fig. 18 - 3 mm
hex wrench

PREPARATION FOR USE

5.1. Configurations

5.1.1. One Probe Cantilever

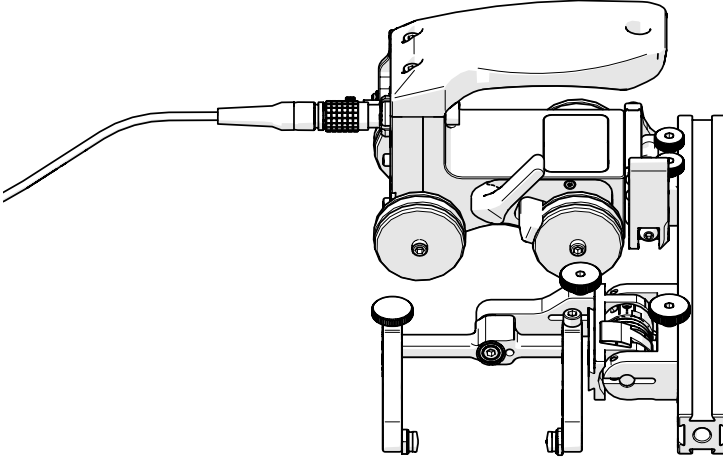

Fig. 19 - One probe cantilever configuration

5.1.2. Two Probe

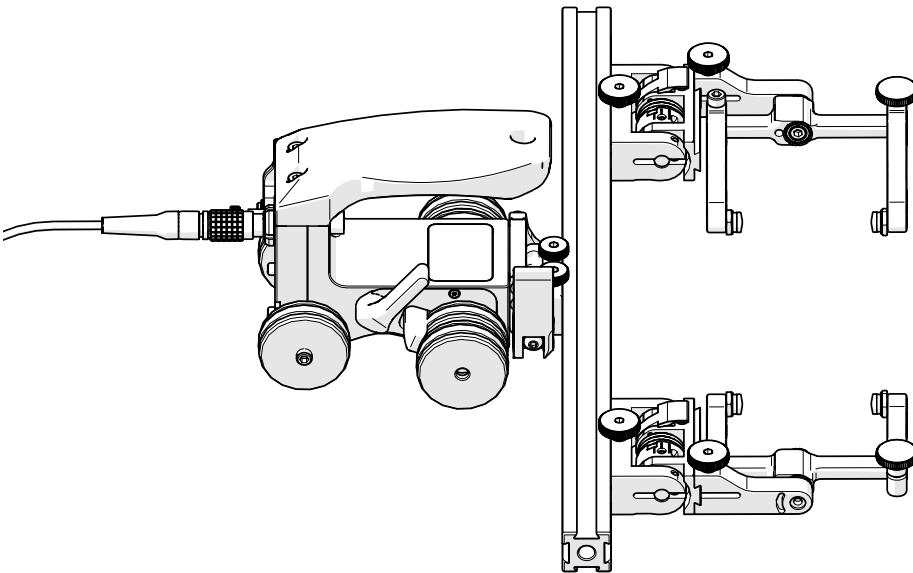

Fig. 20 - Two probe configuration

5.1.3. Two Probe Cantilever

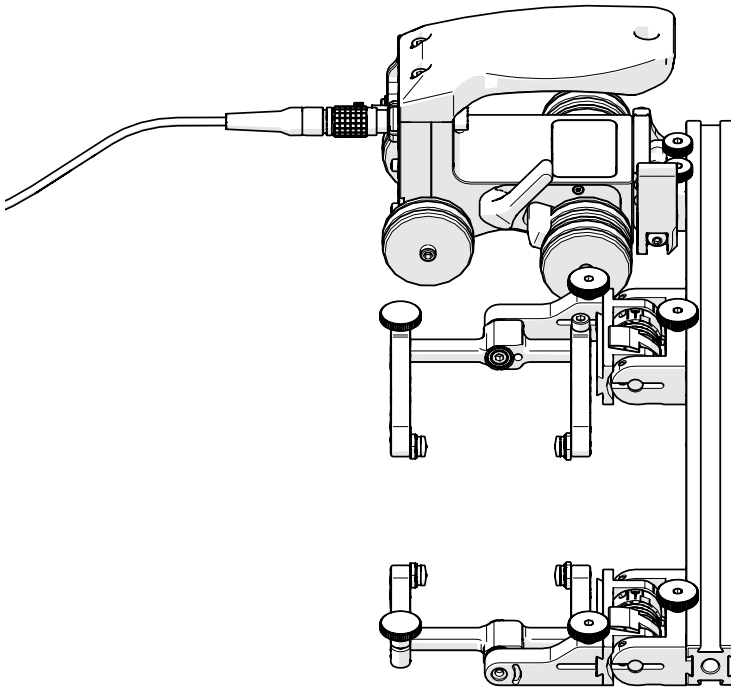

Fig. 21 - Two probe cantilever configuration

5.1.4. Four Probe

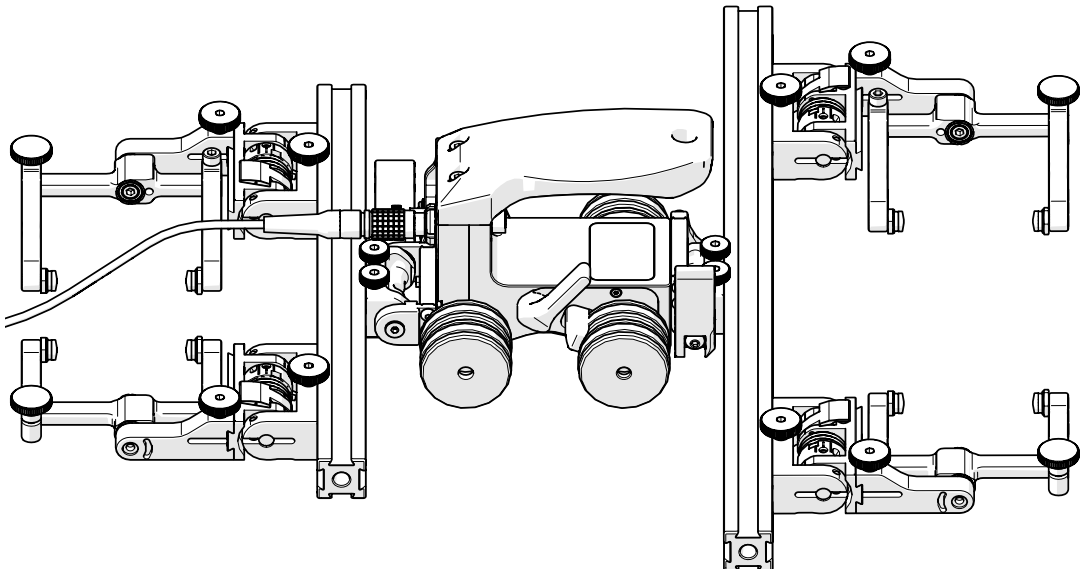

Fig. 22 - Four probe configuration

5.2. Cart Setup And Adjustment

5.2.1. Cart Handle

The handle provides an ergonomic grip during use.

The cart handle may be removed using the supplied 3 mm hex driver to achieve a lower profile when required (*Fig. 23*).

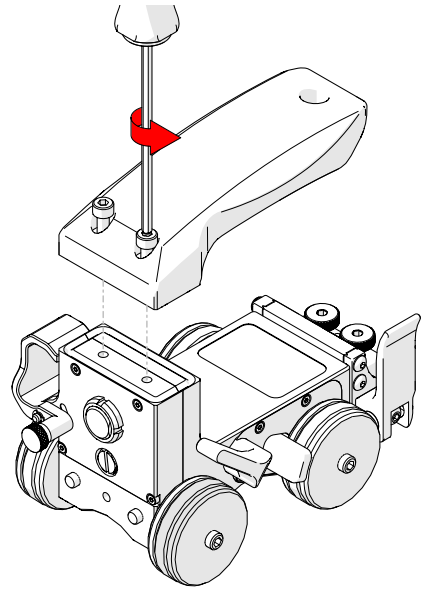

Fig. 23 - Cart handle

5.2.2. Brake Lever

Pivot the red brake lever to engage the braking system. The brake is set when the lever snaps into place (*Fig. 24*).

Reversing this action will disengage the brakes.

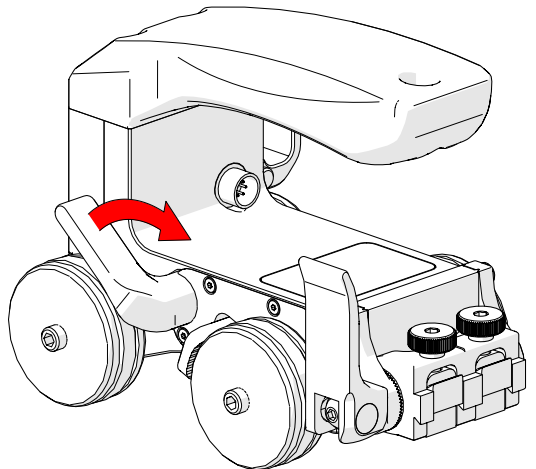

Fig. 24 - Engage brake lever to prevent scanner rolling

5.2.3. Wheel Removal/Installation



WARNING! MAGNETIC MATERIAL. The magnetic wheels produce a magnetic field which may cause failure or permanent damage to items such as watches, memory devices, CRT monitors, medical devices or other electronics. People with pacemakers or ICD's must stay at least 25 cm (10 in) away.

The wheels may be removed and are interchangeable.

To remove/install the cart wheels, insert the provided 3 mm hex driver (Fig. 15) in the end of the shaft opposite the wheel you wish to remove. Thread or unthread the desired wheel by hand (Fig. 25). Additional magnetic wheels may be installed when additional magnetic attraction is required (see *Magnetic Wheel Kit* on page 28).

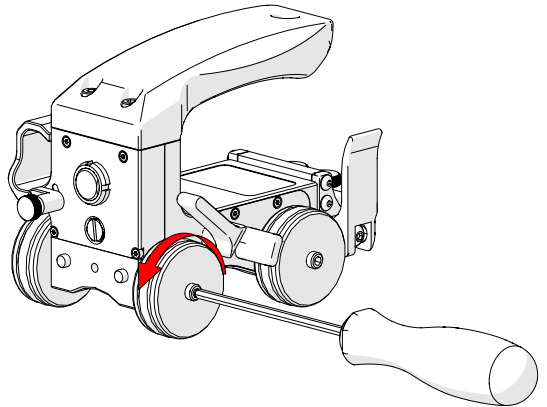

Fig. 25 - Removing wheels

TIP: Ensure all wheels are tight, as this can affect the brake and encoder performance.

NOTE: To increase the magnetic attraction of the additional wheels, it is crucial that the second wheel is repelling the first installed wheel for optimal magnetic performance.

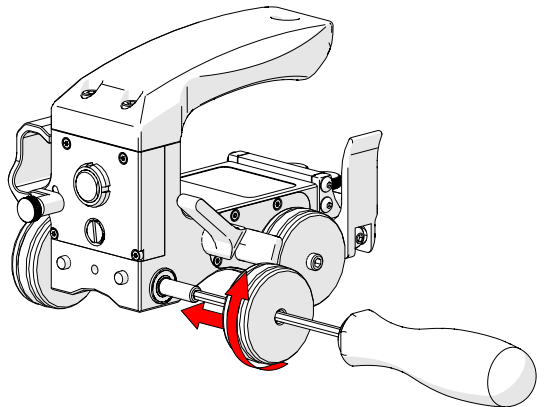

Fig. 26 - Installing wheels

5.2.4. Encoder Cable Connector

The encoder cable connector transmits multiple encoder signals to the user's instrument (Fig. 27).

NOTE: *Inspect the cable and connectors for damage before use. When damage is evident, the cable must **NOT** be used.*

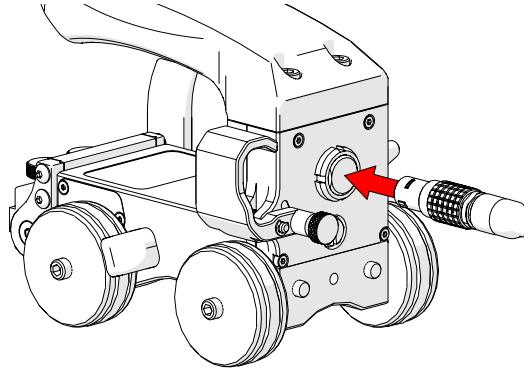

Fig. 27 - Encoder cable connector

5.2.5. Y-Axis Connector

The Y-axis connector provides a connection point for optional accessories, such as PPS encoders that provide positional feedback perpendicular to the direction of cart travel.

The Y-axis connector is found under the cart handle (Fig. 28).

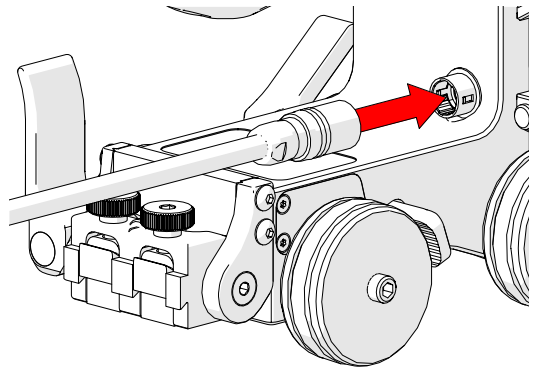

Fig. 28 - Y-axis connector

5.2.6. Pivot Nose

The pivot nose is an attachment point for frame bars.

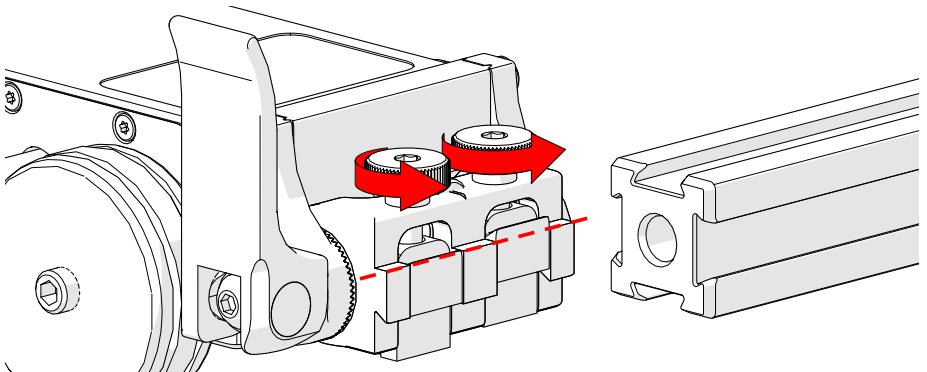

Fig. 29 - Loosen dovetail jaws and align

Loosen the dovetail jaws to align with the frame bar (Fig. 29).

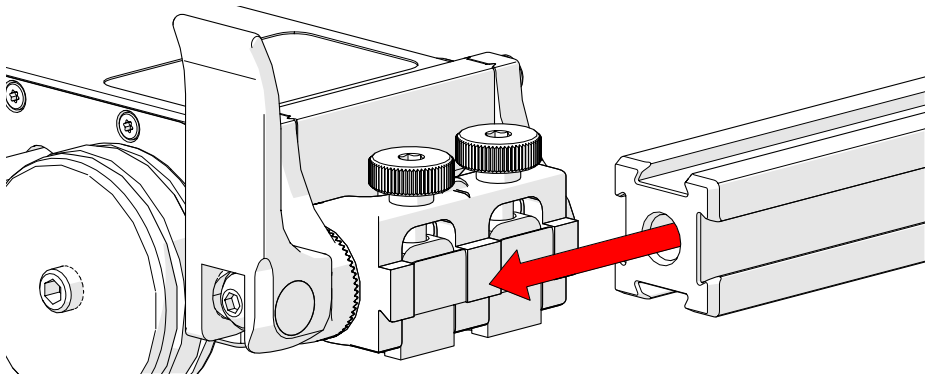

Fig. 30 - Frame bar attachment

Mount the frame bar on the dovetail jaw of the pivot mount and tighten the knobs (Fig. 30).

The angle of the frame bar should be adjusted to match the angle of the inspection surface (see instruction 6 on page 33 for additional details).

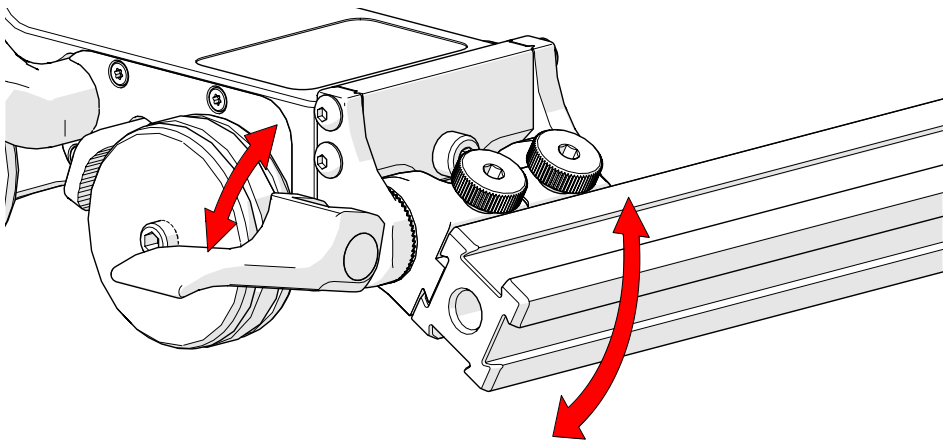

Fig. 31 - Pivot

Loosen the side-mounted lever and pivot to the desired angle, then close the side-mounted lever to lock the frame bar in position (Fig. 31).

5.2.6.1. Pivot Nose Alignment

Tightening the side-mounted lever can damage the pivot's teeth.

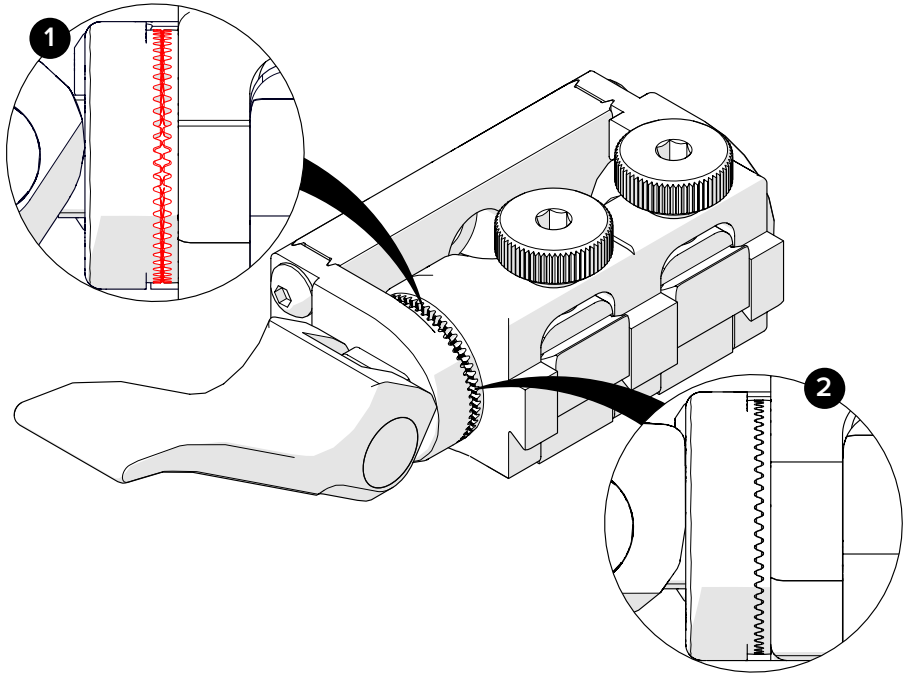

Fig. 32 - Pivot nose alignment

Use caution when tightening the side-mounted lever.

- 1 Ensure the lever is not engaged when the pivot's teeth are aligned tip to tip.
- 2 Align the teeth correctly into the grooves on the opposite side.

5.2.7. Rear Pivot Installation

The rear pivot is positioned at the rear of the cart body and provides an attachment point for frame bars. To mount a rear pivot, follow these steps:

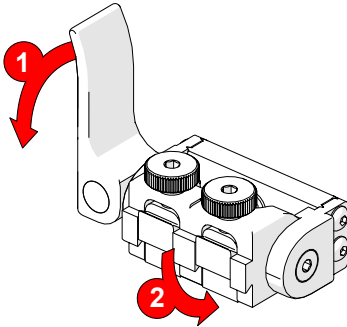

Fig. 33 - Rotate pivot 90° down

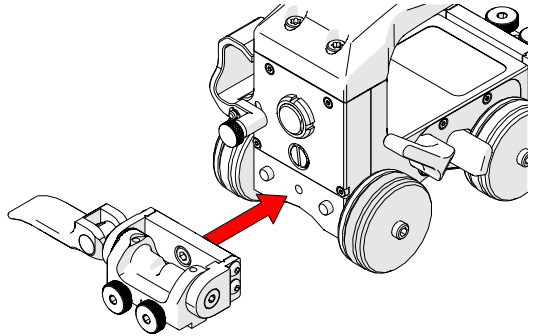

Fig. 34 - Position on cart body

1. Release the side-mounted lever and rotate the pivot down 90° (Fig. 33).
2. Align the rear pivot with the pins at the rear of the cart (Fig. 34).

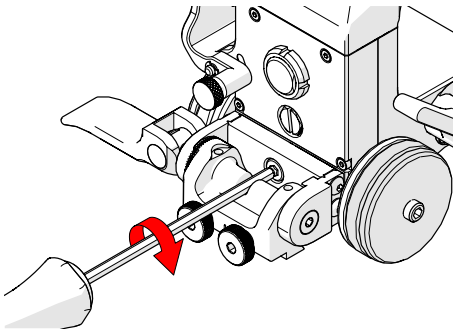

Fig. 35 - Screw to scanner body

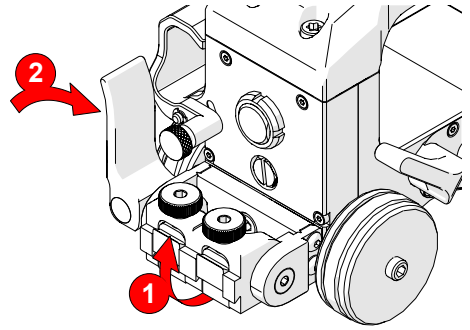

Fig. 36 - Return pivot position

3. Using the supplied 3 mm hex driver, screw the rear pivot to the cart (Fig. 35).
4. Rotate the pivot to the original position and lock the side-mounted lever (Fig. 36).
5. Use caution when tightening the side-mounted lever (see *Pivot Nose Alignment* on page 18)

5.2.8. Cable Management

A convenient clip is provided on the cart body to provide a method to organize and protect cables.

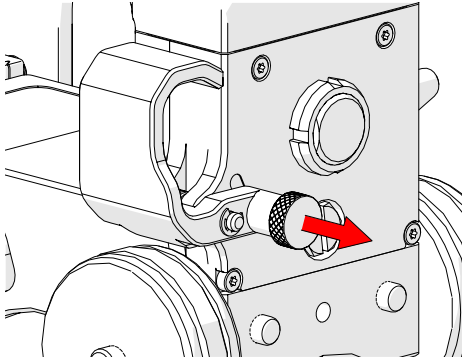

Fig. 37 - Pull latch to open clip

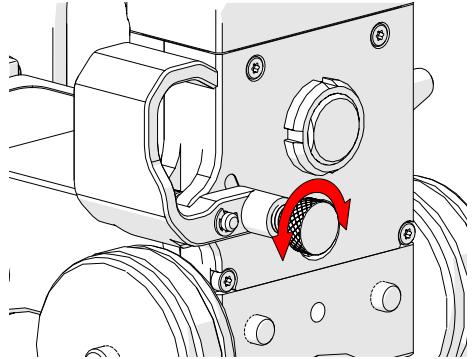

Fig. 38 - Twist latch to maintain clip movement

Pull the latch to open the cable management clip (*Fig. 37*).

Twisting the latch will prevent the latch from locking and, thereby, allow the cable management clip to open freely (*Fig. 38*).

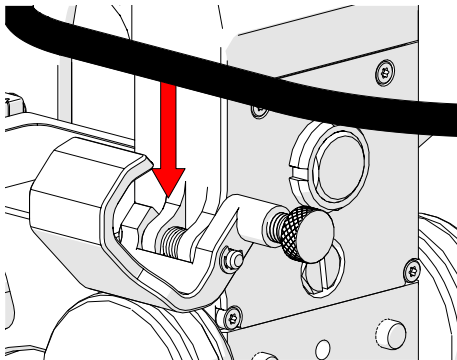

Fig. 39 - Open clip and place cables and hoses

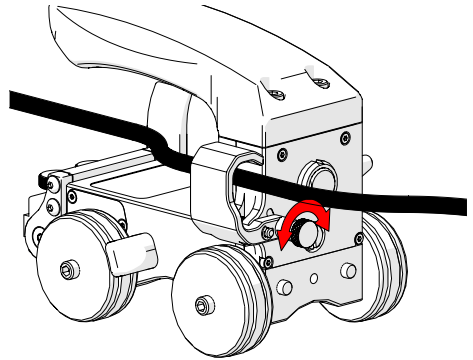

Fig. 40 - Close clip and twist latch to lock

Open the cable management clip and place cables and hoses in the clip as required (*Fig. 39*).

Twist to latch to lock the cable management clip closed (*Fig. 40*).

5.2.9. Anchor Point

The slot in the handle can be used as an anchor point for various equipment (Fig. 41).

NOTE: Carabiner not included.

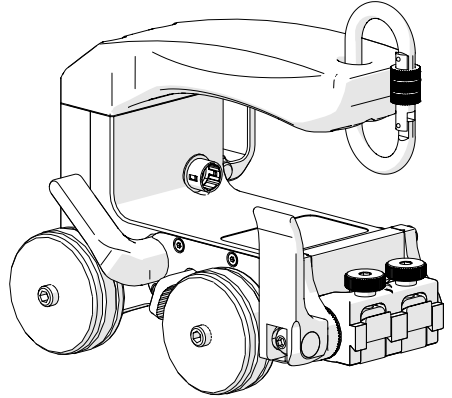

Fig. 41 - Anchor point

5.3. Pivot Buttons

Available in a variety of shapes and sizes, fitting various wedge dimensions.

Use the supplied 3/8 wrench (Fig. 16) to remove and install pivot buttons in the desired hole location (Fig. 42).

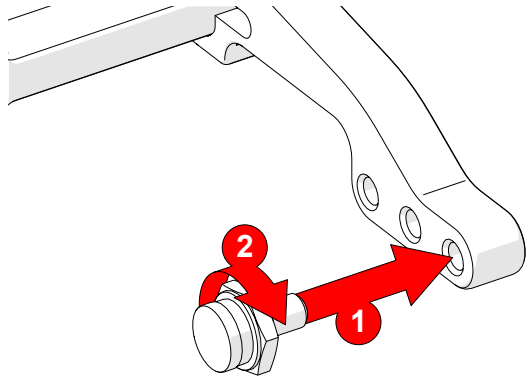

Fig. 42 - Pivot buttons

5.4. Slip Joint Probe Holder

- A Frame Bar
- B Probe Holder Adjustment Knob
- C Latch
- D Swing Arm Knob
- E Yoke
- F Probe Holder Arm Adjustment Knob
- G Probe Holder Arm
- H Arm Clamp Screw
- I Pivot Buttons

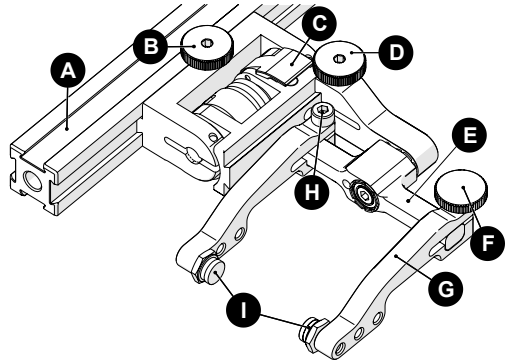

Fig. 43 - Slip joint probe holder

5.4.1. Probe Holder Setup

To mount a UT wedge in the probe holder, follow these steps:

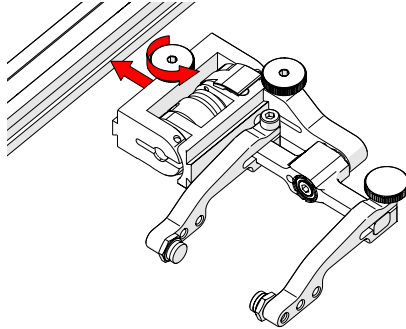

Fig. 44 - Attach to frame bar

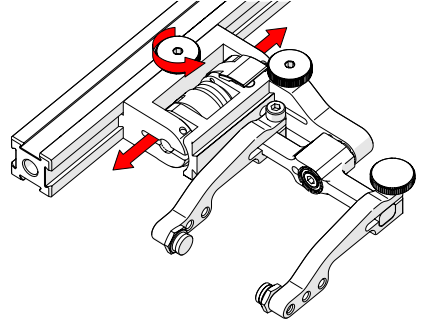

Fig. 45 - Adjust on frame bar

1. Rotate the probe holder adjustment knob and attach the probe holder to a frame bar (Fig. 44).
2. Use the probe holder adjustment knob to position the probe holder along the frame bar (Fig. 45).

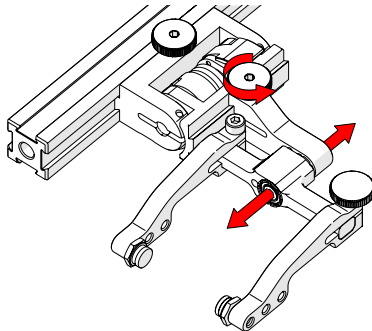

Fig. 46 - Adjust swing arm

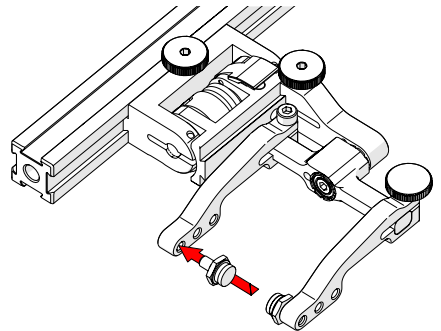

Fig. 47 - Place pivot buttons

- Use the swing arm knob to position the swing arm (Fig. 46).

TIP: The swing arm typically adjusts the TOFD centre-to-centre distance relative to the phased array probes on a four probe configuration (Fig. 22).

- Using the supplied 3/8 in wrench (Fig. 16), place the pivot buttons as required (Fig. 47).

TIP: If a narrow scanning footprint is required, use pivot button holes closest to the yoke. Wedge pivoting may be impeded when closer to the yoke.

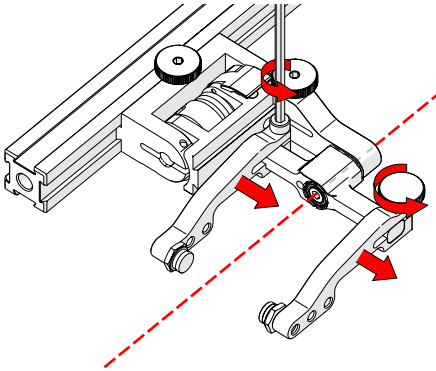

Fig. 48 - Adjust probe holder arms

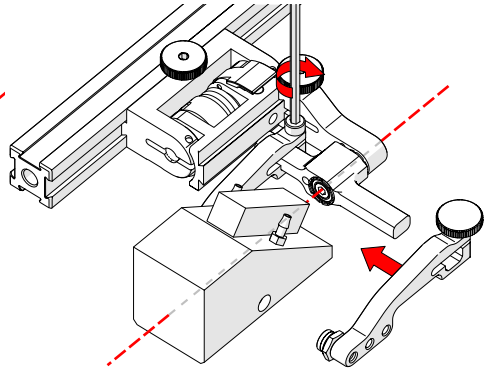

Fig. 49 - Place wedge

- Loosen the arm clamp screw and the probe holder arm adjustment knob (Fig. 48) and remove the outer probe holder arm from the yoke.
- Adjust the inner probe holder arm to best centre the probe on the yoke's pivot axis (Fig. 48).

TIP: The probe holder yoke can accommodate many different probe and wedge sizes of varying widths. It is best to centre the wedge with the yoke's pivot axis to reduce wedge tipping when scanning. Position the inner probe holder arm with the yoke's centre (Fig. 49).

- Position the wedge on the inner probe holder arm (Fig. 49).
- Tighten the arm clamp screw (Fig. 49).
- Slide the outer probe holder arm along the yoke pinching the wedge in place.
- Tighten the probe holder arm adjustment knob (Fig. 50).

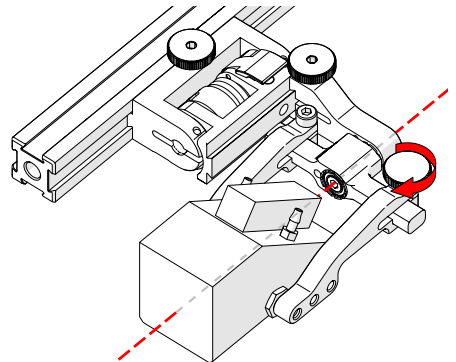

Fig. 50 - Pinch wedge with arm

5.4.2. Probe Holder Adjustment

To adjust the probe holder, follow these steps:

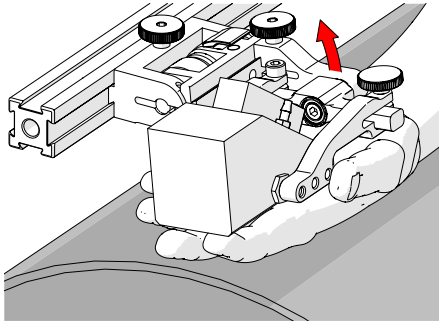

Fig. 51 - Lift to latched position

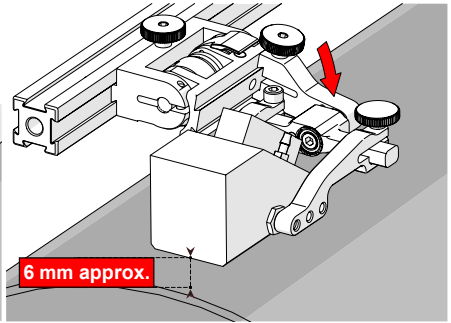

Fig. 52 - Lower to scanning surface

1. Ensure the probe holder is in latched, upper position (*Fig. 51*). If the probe holder is already latched, it will only move within the slip joint adjustment range and have no spring tension.
2. Push the probe holder yoke down toward the inspection surface until the wedge is approximately 6 mm ($\frac{1}{4}$ in) above the inspection surface (*Fig. 52*).

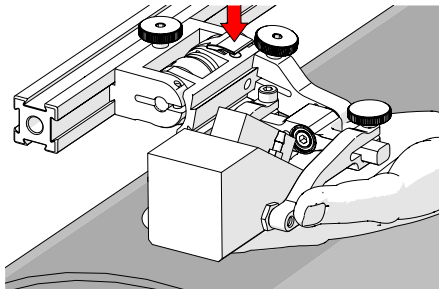

Fig. 53 - Lift and press latch button

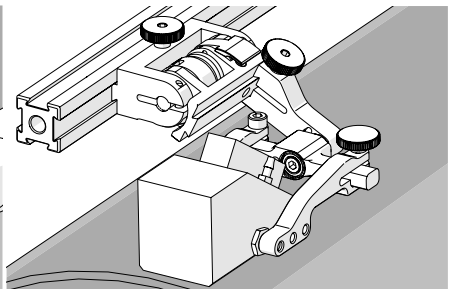

Fig. 54 - Spring loaded scan position

3. Lift the probe slightly and press the latch button (*Fig. 53*) to apply spring pressure to the wedge.
4. Gently lower the probe holder and wedge to the scanning surface (*Fig. 54*).

5.4.3. Probe Holder Force Adjustment

It is possible to adjust the tension of the probe holder spring.

NOTE: The 2 mm hex wrench (*Fig. 17*) and 3 mm hex wrench (*Fig. 18*) are required to perform this operation.

Light	1 kg	2 lb
Medium	2 kg	4 lb
Heavy	3 kg	6 lb

When configured correctly, these settings exert the indicated spring force on the Probe.

To adjust the probe holder's force, follow these steps:

NOTE: Do not perform this operation on the scanning surface.

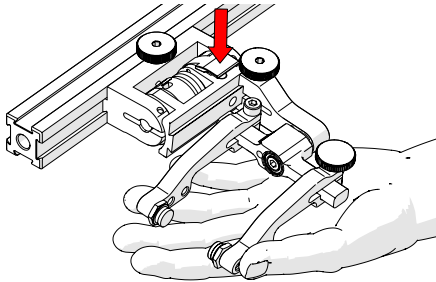

Fig. 55 - Lift slightly and press Latch

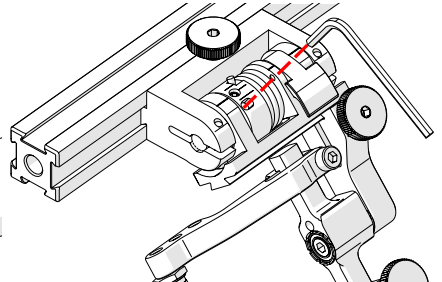

Fig. 56 - Unlatched position

1. Ensure the probe holder is in the upright latched position (Fig. 51).
2. Lift the probe holder slightly and press the latch button (Fig. 55) to release the probe holder to the full 45° degrees.
3. Insert the short arm of a 3 mm hex wrench into the 3 mm slot (Fig. 56).

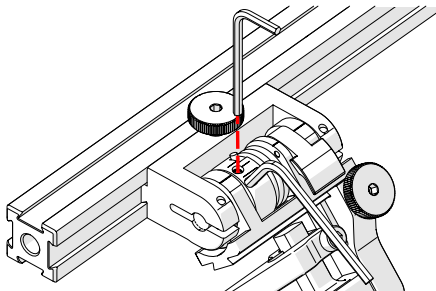

Fig. 57 - Insert hex wrenches

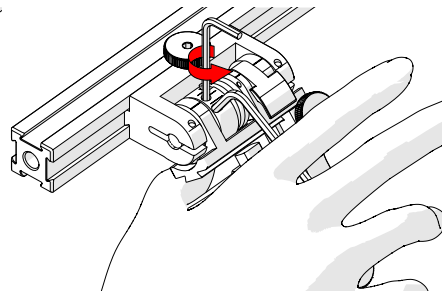

Fig. 58 - Press 3 mm hex wrench down

4. Place the 2 mm hex wrench into the force adjustment screw (Fig. 57).
5. Lightly press the long arm of the 3 mm hex wrench down. Using the 2 mm hex wrench, loosen the force adjustment screw but do not remove it (Fig. 58).
6. Gently apply pressure on the long leg of the 3 mm hex wrench until the force adjustment marker lines up with the desired spring tension. While keeping the markers in line, tighten the force adjustment screw (Fig. 59).

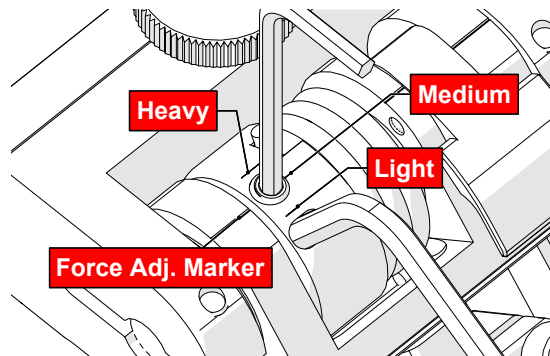

Fig. 59 - Choose desired tension

5.4.4. Slip Joint Probe Holder Left/Right Conversion

To reverse the probe holder, follow these steps:

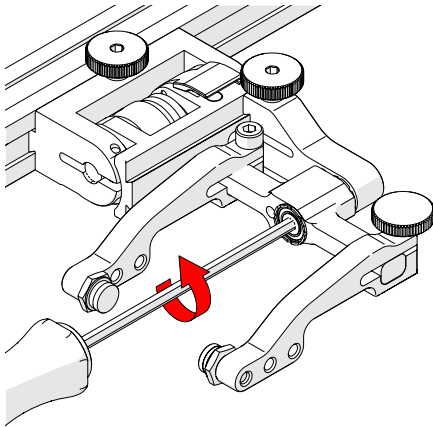

Fig. 60 - Unscrew yoke pivot screw

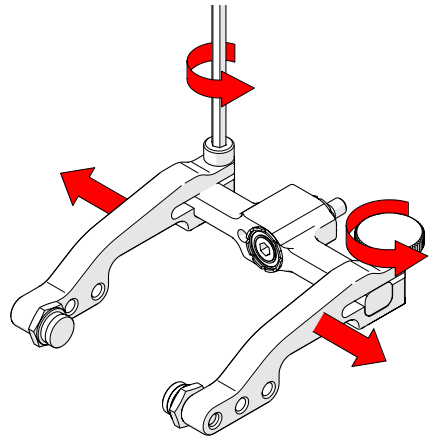

Fig. 61 - Remove arms

1. Unscrew the yoke from the swing arm (Fig. 60).
2. Loosen the probe holder arm adjustment knob and arm clamp screw. Slide the arms from the yoke (Fig. 61).

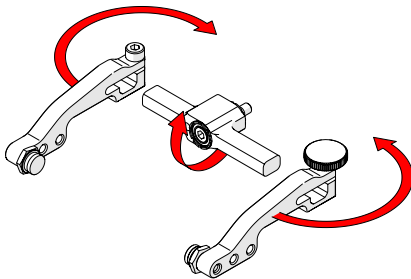

Fig. 62 - Flip yoke and reverse arms

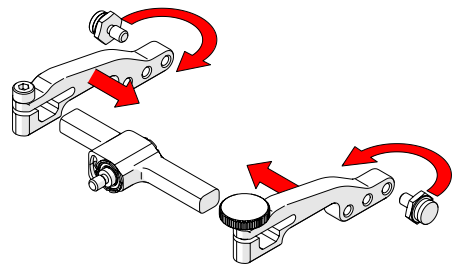

Fig. 63 - Attach arms and move buttons

3. Flip the yoke 180° and reverse the probe holder arms (Fig. 62).
4. Place the pivot buttons on the inside of the probe holder arms (Fig. 63) using a 3/8 in wrench (Fig. 16). Slide the arms onto the yoke and tighten the probe holder arm adjustment knob and the arm clamp screw.

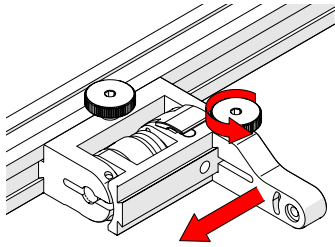

Fig. 64 - Position swing arm

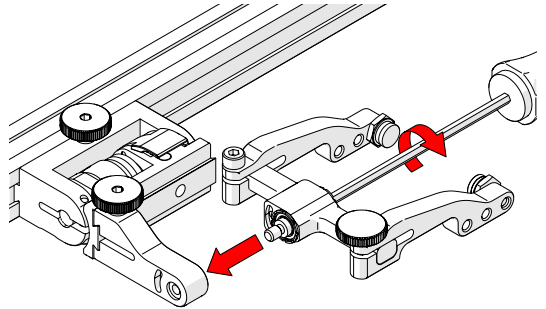

Fig. 65 - Install yoke to swing arm

5. Loosen the swing arm knob and slide the swing arm to the opposite end of the probe holder bracket (*Fig. 64*) or the preferred position. Tighten the swing arm knob.
6. Using the 3 mm hex driver, screw the yoke pivot screw into the opposite side of the probe holder swing arm (*Fig. 65*). Ensure the yoke is level to avoid issues with the plunger/set screw.

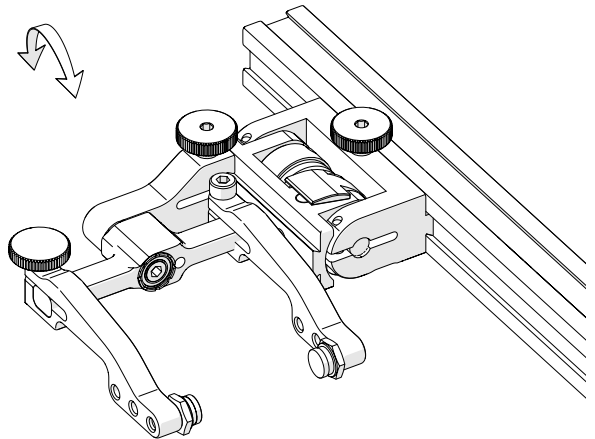

Fig. 66 - Reversed probe holder

5.5. Magnetic Wheel Kit



WARNING! MAGNETIC MATERIAL. The magnetic wheel kit produce a magnetic field which may cause failure or permanent damage to items such as watches, memory devices, CRT monitors, medical devices or other electronics. People with pacemakers or ICD's must stay at least 25 cm (10 in) away.

An additional magnetic wheel kit can also be used on the cart body, thus doubling the magnetic force (Fig. 67).

To install or remove single wheels (see *Wheel Removal/Installation* on page 15).

1. Ensure the four existing wheels are tight (see *Wheel Removal/Installation* on page 15).

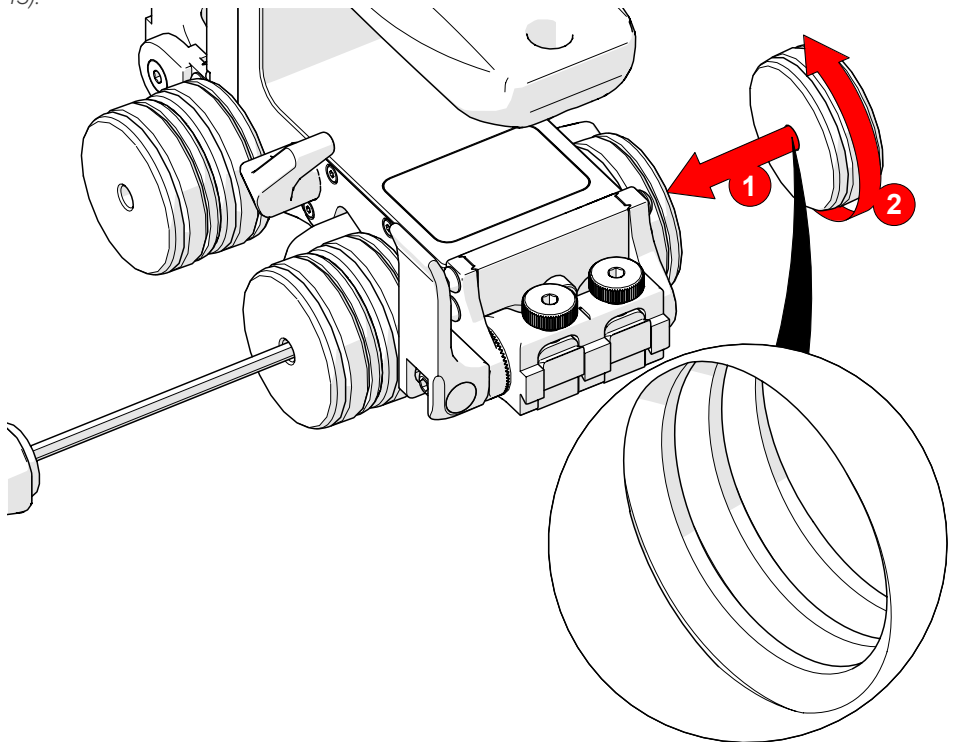

Fig. 67 - Magnetic wheel kit

2. On the magnetic wheel to be attached, locate the threaded side of the magnetic wheel, and orient the threaded side towards the cart (Fig. 67).
3. Overcome the magnetic resistance to screw the additional wheel to the axle of the cart (Fig. 67-1).

NOTE: To increase the magnetic attraction of the additional wheels, it is crucial that the second wheel is repelling the first installed wheel for optimal magnetic performance.

4. Insert the 3 mm hex driver into the opposite axle and tighten the additional wheel (Fig. 67-2).

TIP: To remove wheels, reverse these steps.

5.6. Cable Clips

Clips have been provided to assist with cable management. Pinch the clip and press it into the dovetail groove of the frame bar.

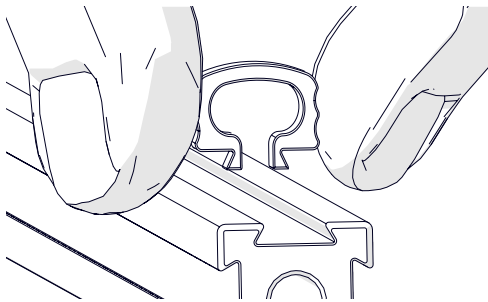

Fig. 68 - Pinch clip

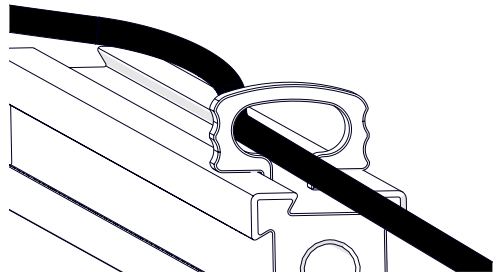

Fig. 69 - Route cables

5.7. Preamp Bracket

Compatible with most standard preamps, use screws or velcro straps to attach a preamp to the preamp bracket.

Intended Use:

- ▶ The preamp bracket is intended to mount objects (*e.g. preamps, splitters, etc.*) that:
- ▶ have a maximum weight of 1.36 kg (3 lb)
- ▶ are attached to the with a lanyard or probe cables strong enough to prevent the object from falling
- ▶ have smooth edges so as not to cut the preamp velcro strap

5.7.1. Mounting Preamp Bracket

The preamp bracket mounts to any dovetail groove.

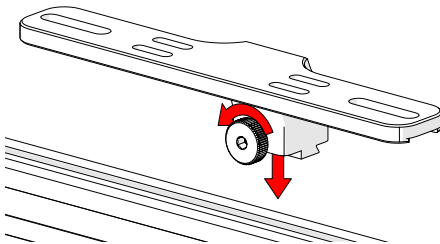

Fig. 70 - Loosen knob and mount to dovetail groove

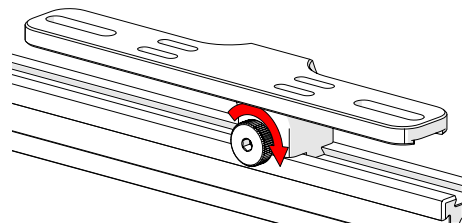

Fig. 71 - Tighten knob

1. Loosen the knob and align with the dovetail groove (*Fig. 70*).
2. Tighten the knob to lock the preamp bracket in place (*Fig. 71*).

5.7.2. Attaching Preamp with Screws

Use the adjustable screw mounting channel on the bottom of the bracket to attach a preamp (*screws not included*).

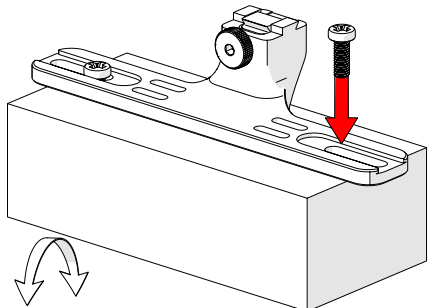

Fig. 72 - Attach preamp with screws

5.7.3. Attaching Preamp with Velcro Strap

To attach the preamp to the bracket using velcro straps, follow these steps:

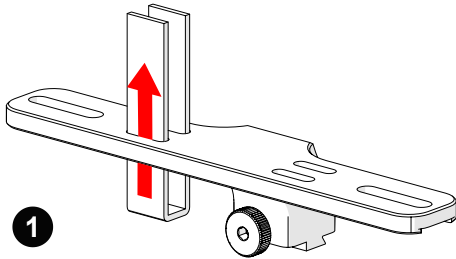

Fig. 73 - Insert velcro straps

1. Slide the velcro strap through the bracket's holes (Fig. 73).
2. Centre and place the preamp on the bracket wrapping the velcro around the preamp (Fig. 74).
3. Secure the preamp to the bracket attaching each side of the velcro (Fig. 75).

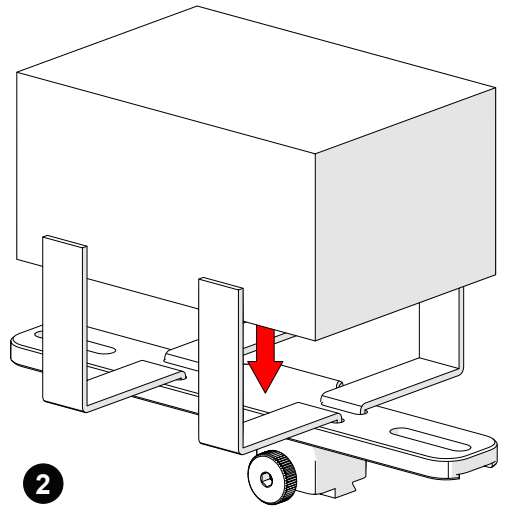

Fig. 74 - Place preamp and wrap velcro

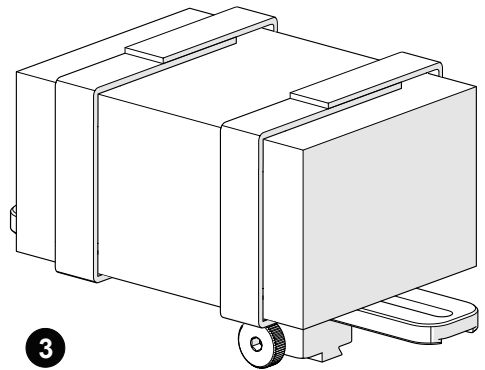

Fig. 75 - Preamp is ready to be mounted to a frame bar

OPERATION

6.1. MICROBE Setup on a Scanning Surface

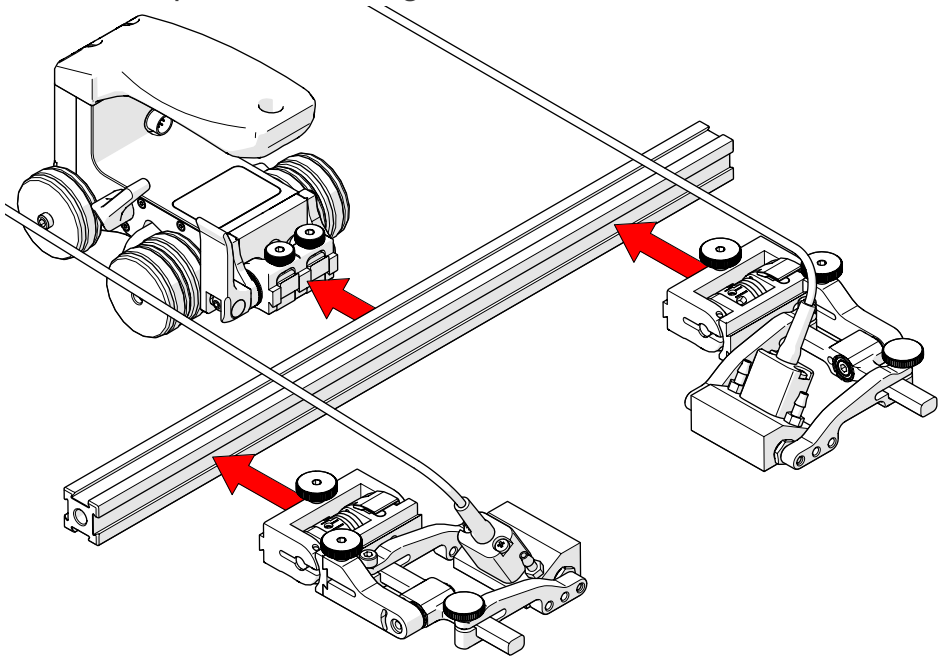

Fig. 76 - Assemble configuration

1. Install the wedge and probes that will be used (see *Slip Joint Probe Holder* on page 22).
2. Assemble the appropriate configuration to the cart (Fig. 76).
3. Route cables and hoses through the cart's cable management clip (Fig. 77).
4. Cable clips may also be used to route hoses and cables (see *Cable Clips* on page 29).

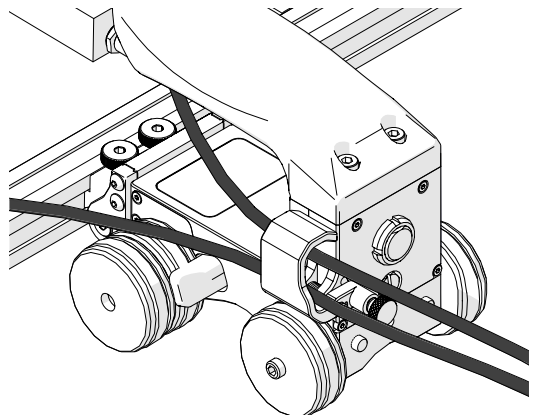

Fig. 77 - Cable management

5. Connect the encoder cable to the cart (Fig. 78).

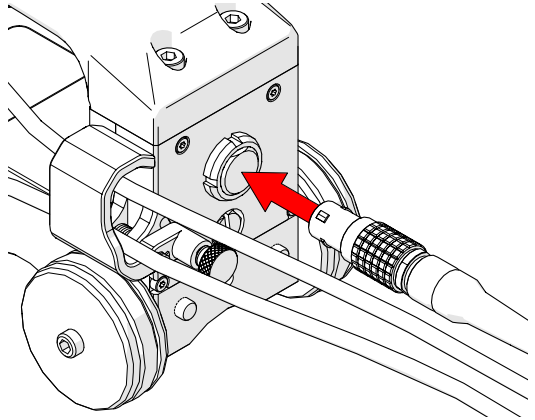

Fig. 78 - Connect encoder cable

6. Ensure the cart's brake is locked (see *Brake Lever* on page 14).
7. Place the configured **MICROBE** on the scan surface (Fig. 79).

TIP: Use caution when placing the scanner on the inspection surface. The magnetized wheels can cause the scanner to lurch toward the inspection surface.

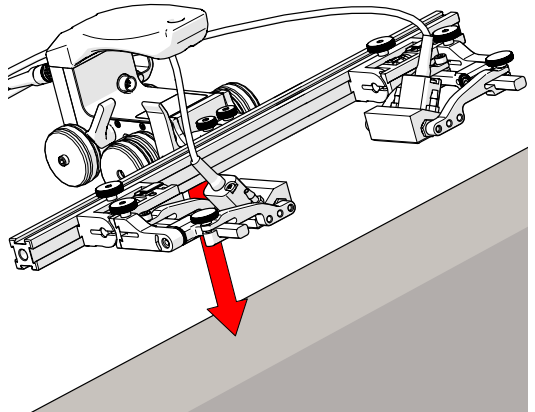

Fig. 79 - Place on scan surface

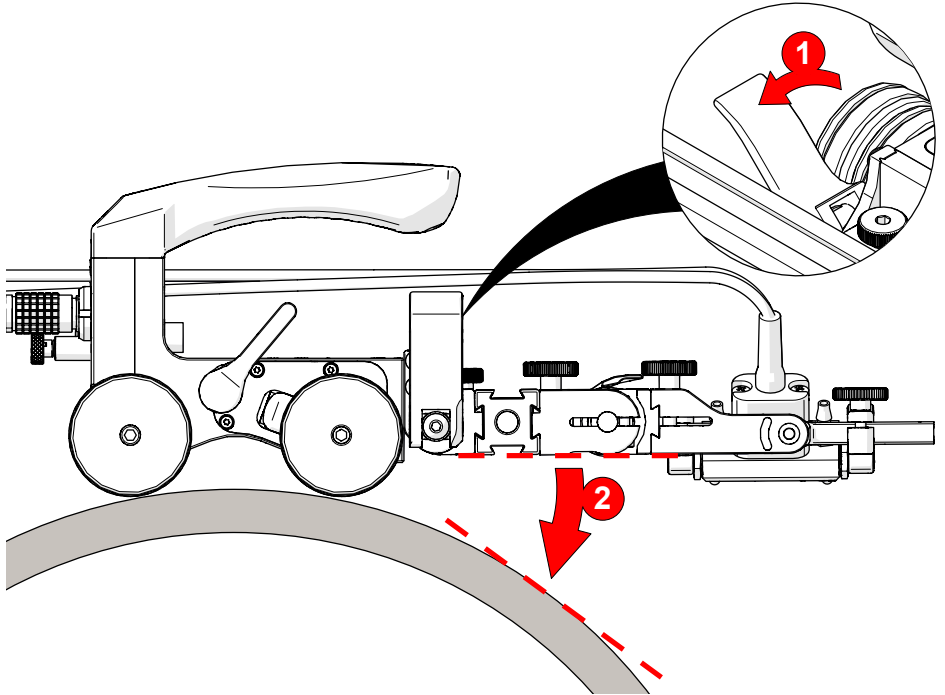

Fig. 80 - Lower pivot nose

8. Adjust the pivot nose (Fig. 80-1) angle to align the frame bar (Fig. 80-2) parallel with the tangent of the scan surface (Fig. 81).

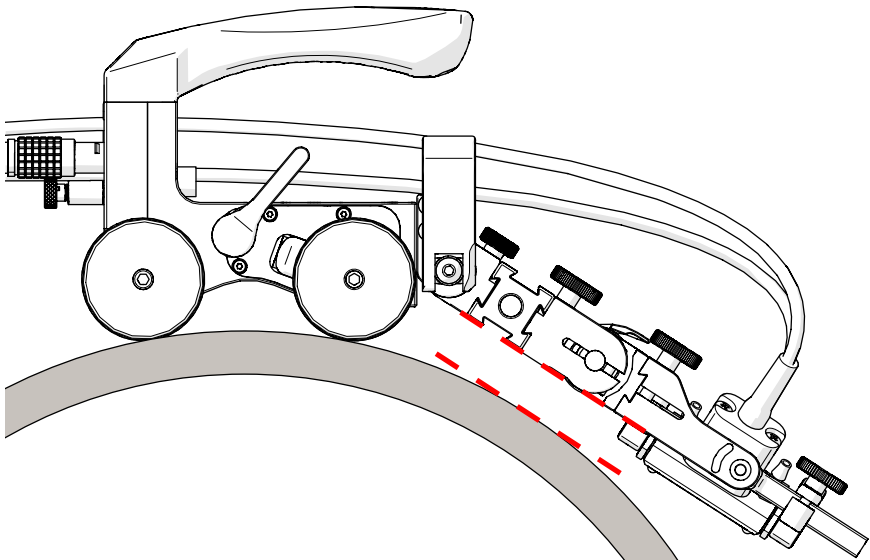

Fig. 81 - Parallel with scan surface tangent

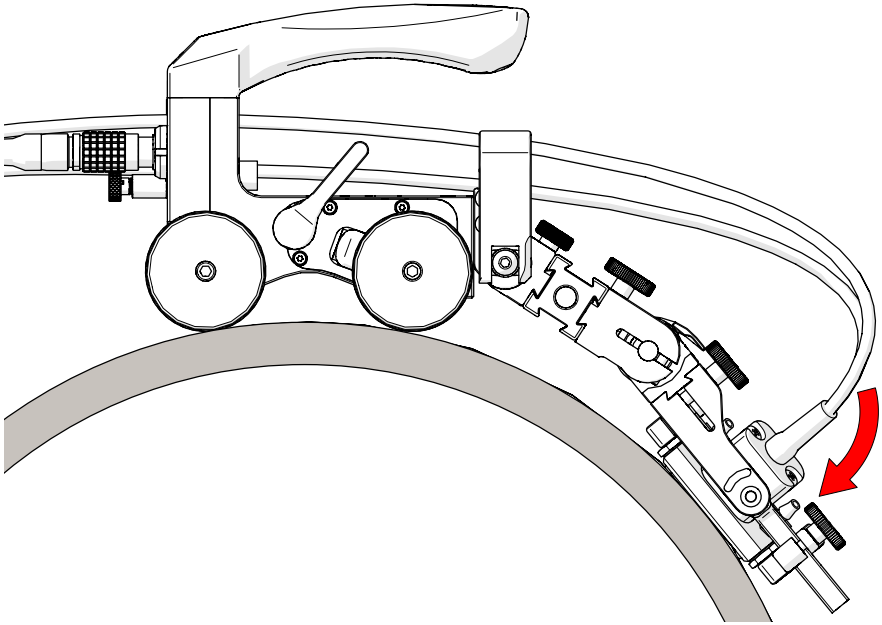

Fig. 82 - Lower probes to scan surface

9. Lower the probes (Fig. 82) to the scan surface using the probe holders (see *Probe Holder Adjustment* on page 24).

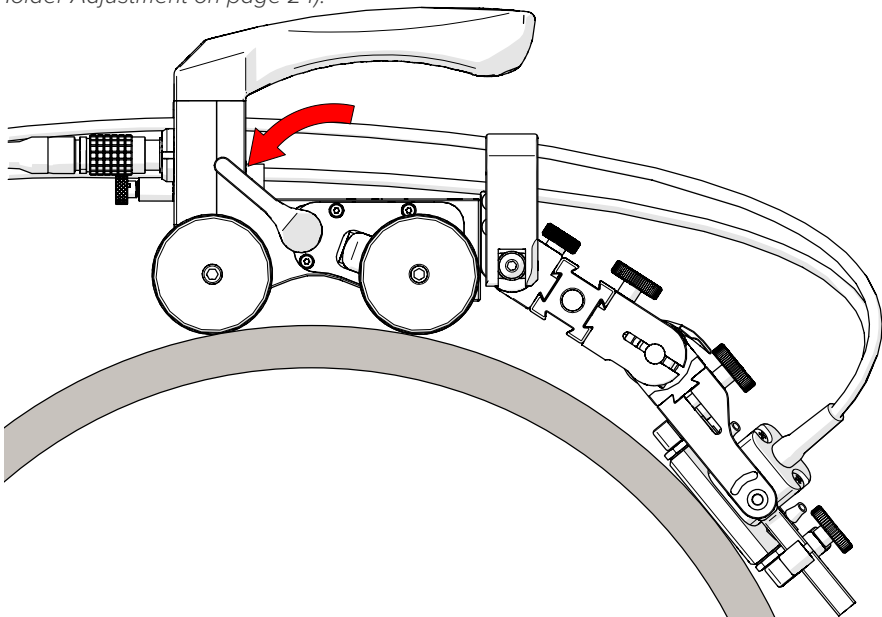

Fig. 83 - Release brake

10. Release the brake to begin the inspection process (Fig. 81).

MAINTENANCE

General cleaning of components is essential to keep your system working well. All components that have no wiring or cables are completely waterproof. Components can be washed with warm water, dish soap and a medium bristle brush.

Before using the scanner, ensure all connectors are free of water and moisture.

NOTE: *All components with wiring, cables or electrical connections are splashproof. However, these components are **NOT** submersible.*

NOTE: *Never use strong solvents or abrasive materials to clean your scanner components.*

TROUBLESHOOTING

Problem	Possible Cause	Solution
Can not close the side-mounted lever on the pivot nose/tail.	The rosettes of the lever and the pivot are not lined up.	Slightly wiggle the pivot nose/tail while locking the side-mounted lever allowing the rosettes to seat appropriately.
Insufficient probe contact.	The scanner is not set correctly.	Reconfigure the scanner as per instructions (see <i>MICROBE Setup on a Scanning Surface on page 32</i>)

8.1. Technical Support

For technical support, contact Jireh Industries (see *Jireh Industries Ltd. on page 1*).

SERVICE AND REPAIR



WARNING! DO NOT DISASSEMBLE. No user-serviceable parts. Disassembling any of the components in this product, beyond the instructions in this user manual, could void the regulatory certifications and/or effect the safety of the product.

SPARE PARTS

To order accessories or replacement parts for your **MICROBE** system.
 (contact Jireh Industries Ltd. on page 1)

NOTE: These drawings are for a parts order. This is not a list of kit contents.

10.1. MICROBE Cart

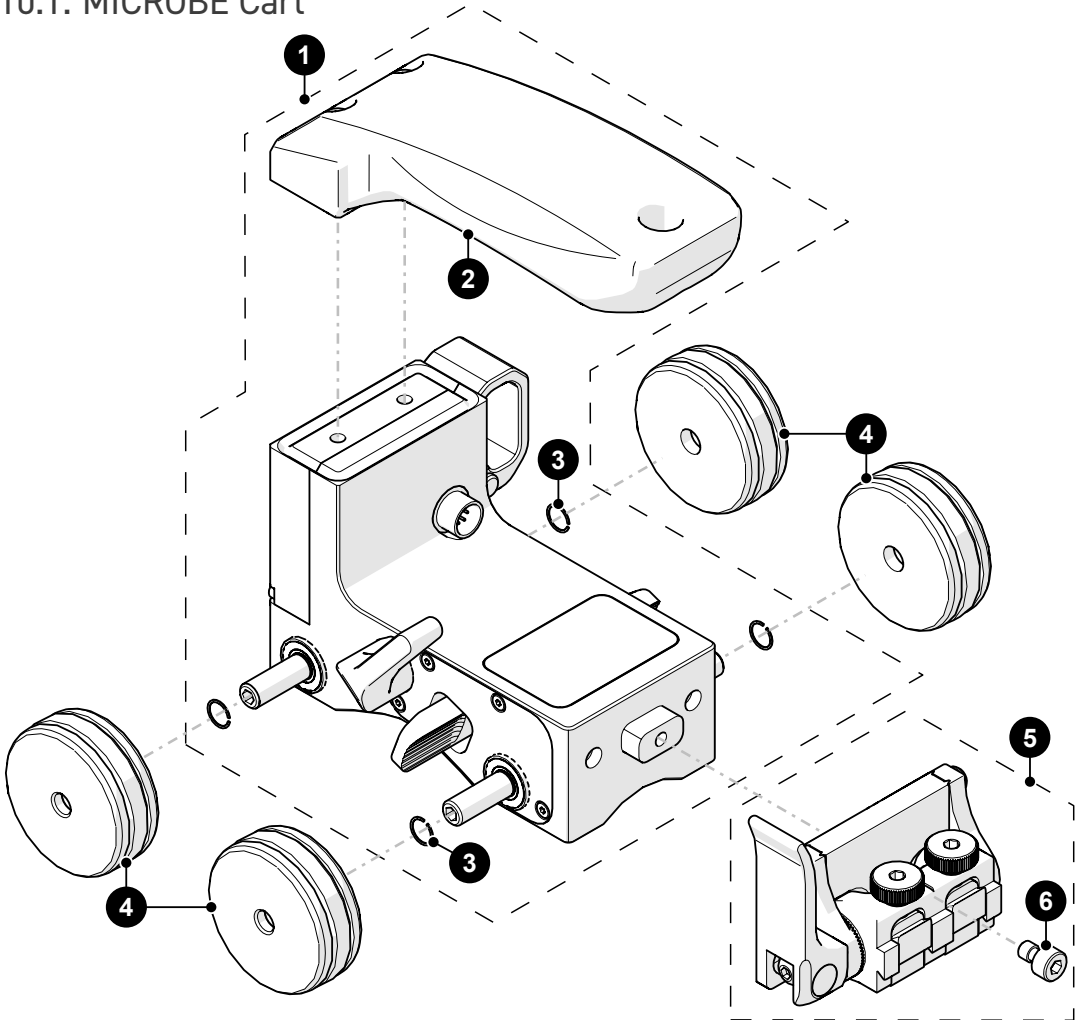

Fig. 84 - MICROBE cart parts

BOM ID	Part #	Description
1	BTS054	Base cart

2	BTS058	MICROBE/ROTIX handle
3	MA042	Axle retaining ring - 6mm
4	BTS031	Magnetic wheel
5	BTS040	MICROBE/ROTIX front pivot
6	MA222	COVER BOLT, M4x6 (3mm THD LENGTH) SHCS TYPE, SST

10.2. Kit Components

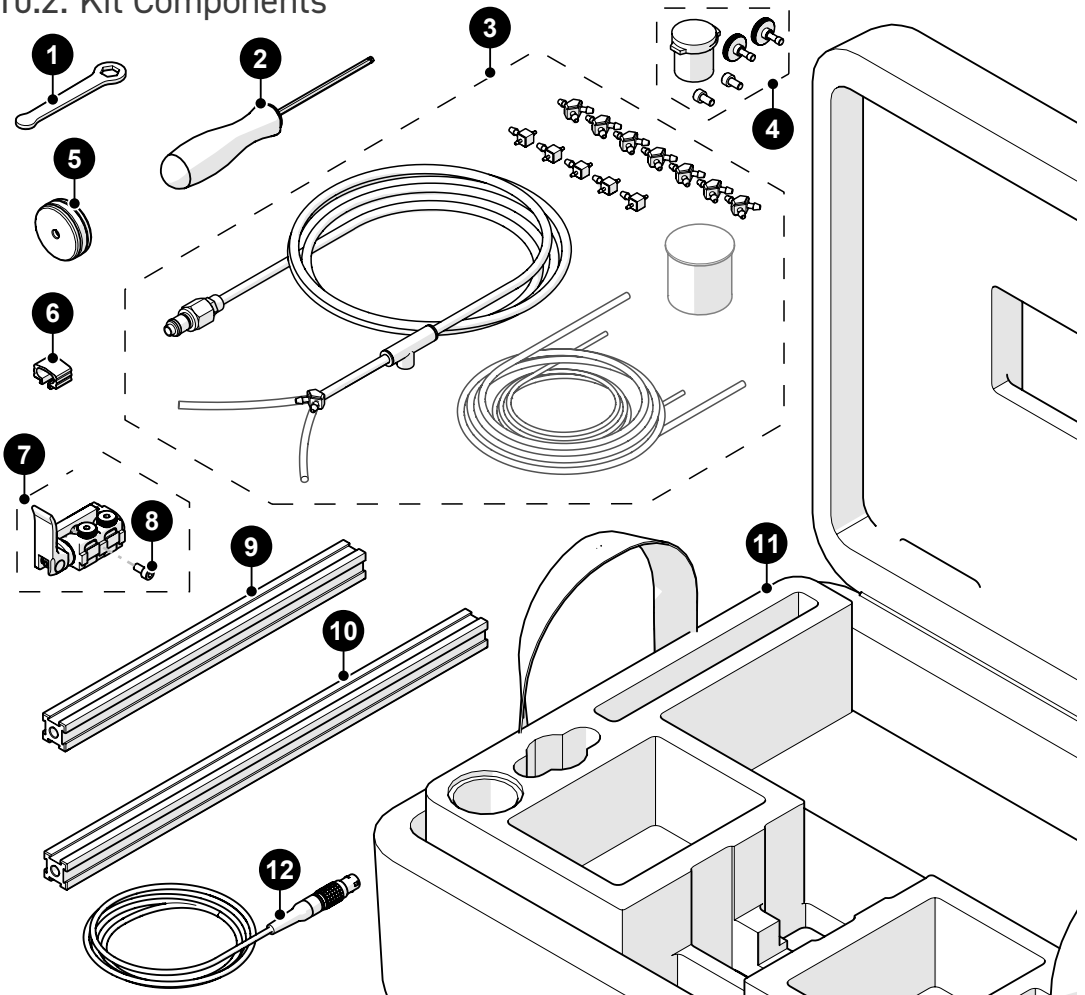

Fig. 85 - MICROBE cart parts

BOM ID	Part #	Description
1	EA470	10 mm (3/8 in) wrench
2	EA414	Hex driver, 3 mm (0.118 in)

3	CMG007	Irrigation kit, 2-4 probe
4	PHG014	2 probe spare parts kit
5	BTS031	Magnetic wheel
6	BG0091	Cable clip
7	BTS042	MICROBE rear pivot
8	MD050-008	SHCS, M4x0.7 X 8mm, SST
9	BG0038-25	Frame bar, 25 cm (<i>see frame bars</i>)
10	BG0038-35	Frame bar, 35 cm (<i>see frame bars</i>)
11	BTA002	MICROBE case
12	UMA026-_	J100 encoder cable (<i>see Encoder Connector Type</i>)

10.2.1. Encoder Connector Type

Connector Type	Company/Instrument	Connector Type	Company/Instrument
B	Olympus OmniScan MX Zetec Topaz	G	Sonotron Isonic 25xx
C	Olympus Focus LT Zetec Z-Scan Eddyfi Ectane 2	U	Sonatest Veo / Prisma
E	Olympus OmniScan SX/MX2/X3 M2M MANTIS/GEKKO LEMO	V	Pragma PAUT
F	TD (<i>Technology Design</i>)	AD	Sonatest Veo / Prisma - Single Axis

NOTE: Additional encoder connector styles are available.
(contact Jireh Industries Ltd. on page 1 for details)

10.3. Probe Holders

10.3.1. Slip Joint Probe Holder Parts

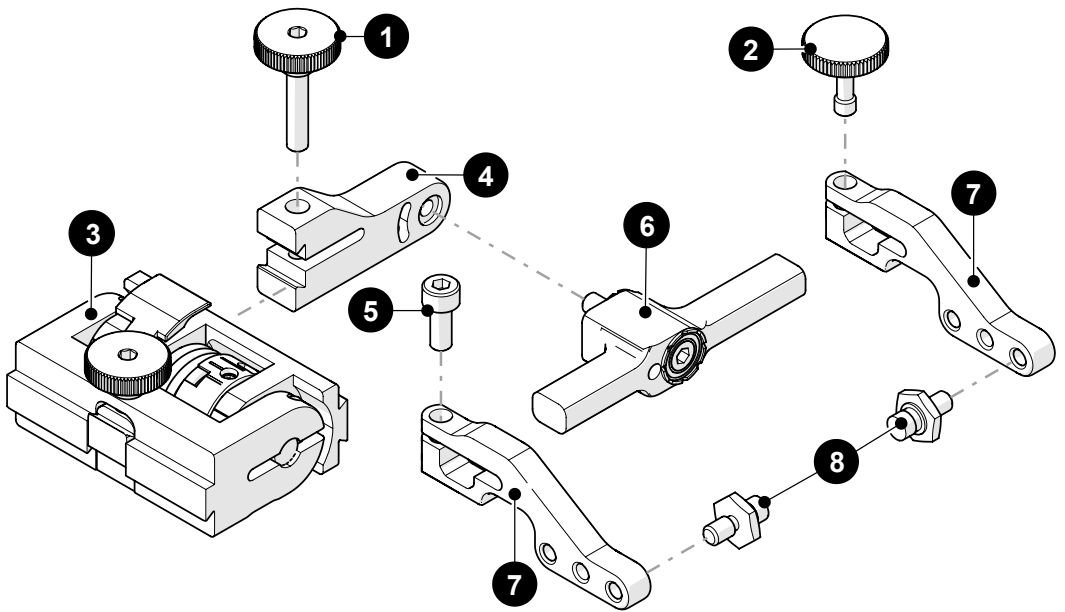

BOM ID	Part #	Description
1	PH0104	Knurled Knob, M4 x 0.7 x 18 mm, 4 mm stand off, SST
2	PH0082	Knurled Knob, M4 x 0.7 x 10 mm, 3 mm stand off, SST
3	PHS022	Slip Joint Probe Holder Subassembly
4		<i>see Swing Arm Style</i>
5	MD050-010	SHCS, M4 x 0.7 x 10 mm, SST
6		<i>see Yoke Style</i>
7		<i>see Arm Style</i>
8	PH0011- <u> </u>	Pivot Button Style (<i>see Pivot Button Style</i>)

Fig. 86 - Slip joint probe holder parts

10.4. Probe Holder Components

10.4.1. Arm Style











Arm Style	Part #		Arm Style	Part #	
A Standard, Flat	PH0090		B Short, Flat	PH0089	
C Long, Flat	PH0099		D Standard, Drop	PH0093	
E Short, Drop	PH0092		F Long, Drop	PH0094	
G Standard, Extra-Drop	PH0096		H Short, Extra-Drop	PH0095	
I Extra-Short, Flat	PH0159		J Extra-Short, Drop	PH0161	

Fig. 87 - Probe holder arm selection

10.4.2. Yoke Style

Yoke Style	Part #	Length		Yoke Style	Part #	Length	
S Standard	PHS052	6.3 cm (2.47 in)		W Wide	PHS063	7.9 cm (3.06 in)	

Fig. 88 - Probe holder yoke selection

10.4.3. Swing Arm Style

Swing Arm Style	Part #	Length		Swing Arm Style	Part #	Length	
Short	PH0069	4.1 cm (1.61 in)		Long	PH0100	4.6 cm (1.81 in)	

Fig. 89 - Swing arm selection

NOTE: Short swing arm only compatible with standard yoke style.

10.4.4. Pivot Button Style











Pivot Hole Size	Wedge Type		Pivot Hole Size	Wedge Type	
01 8.0 mm (0.315 in)	Olympus PA		02 5.0 mm (0.197 in)	Olympus TOFD	
03 2.7 mm (0.106 in)	Sonatest DAAH PA		04 9.5 mm (0.375 in)	-	
06 3.0 mm (0.118 in)	-		07 2.3 mm (0.09 in)	-	
08 Conical Head	-		09 5 mm (0.197 in) Internal	Zetec PA/TOFD	
11 3 mm (0.118 in) Internal	-		14 4 mm (0.157 in)	-	

Fig. 90 - Pivot button selection

NOTE: Additional probe holder pivot buttons are available. (contact Jireh Industries Ltd. on page 1)

10.5. Variable Components

10.5.1. Frame Bars











Part #	Length		Part #	Length	
BG0038-05	5 cm (1.97 in)		BG0038-10	10 cm (3.94 in)	
BG0038-15	15 cm (5.91 in)		BG0038-20	20 cm (7.87 in)	
BG0038-25	25 cm (9.84 in)		BG0038-30	30 cm (11.81 in)	
BG0038-35	35 cm (13.78 in)		BG0038-40	40 cm (15.75 in)	
BG0038-45	45 cm (17.72 in)		BG0038-50	50 cm (19.69 in)	
BG0038-55	55 cm (21.65 in)				

Fig. 91 - Frame bar selection

10.6. Accessories

10.6.1. Magnetic Wheel Kit

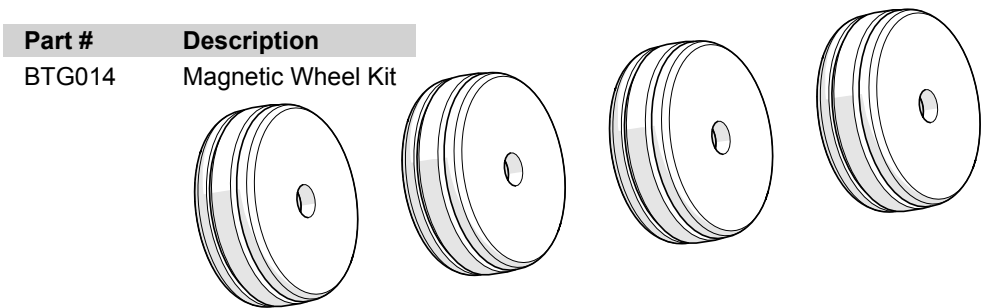

Fig. 92 - Magnetic wheel kit

10.6.2. Preamp Bracket

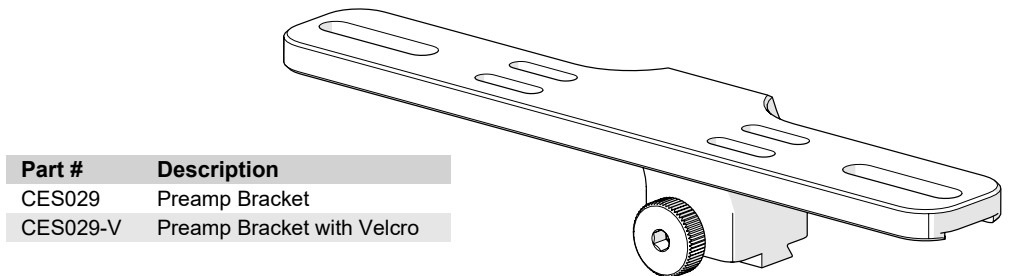
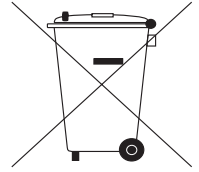

Fig. 93 - Preamp bracket

DISPOSAL

WEEE Directive

In accordance with European Directive on Waste Electrical and Electronic Equipment (WEEE), this symbol indicates that the product must not be disposed of as unsorted municipal waste, but should be collected separately. Refer to Jireh Industries for return and/or collection systems available in your country.



LIMITED WARRANTY

WARRANTY COVERAGE

Jireh Industries warranty obligations are limited to the terms set forth below: Jireh Industries Ltd. (“Jireh”) warrants this hardware product against defects in materials and workmanship for a period of THREE (3) YEARS from the original date of purchase. If a defect exists, at its option Jireh will (1) repair the product at no charge, using new or refurbished replacement parts, (2) exchange the product with a product that is new or which has been manufactured from new or serviceable used parts and is at least functionally equivalent to the original product, or (3) refund the purchase price of the product. A replacement product/part assumes the remaining warranty of the original product or ninety (90) days from the date of replacement or repair, whichever provides longer coverage for you. When a product or part is exchanged, any replacement item becomes your property and the replaced item becomes Jireh’s property. When a refund is given, your product becomes Jireh’s property.

OBTAINING WARRANTY SERVICE

To utilize Jireh’s warranty service you must ship the product, at your expense, to and from Jireh Industries. Before you deliver your product for warranty service you must phone Jireh and obtain an RMA number. This number will be used to process and track your product. Jireh is not responsible for any damage incurred during transit.

EXCLUSIONS AND LIMITATIONS

This Limited Warranty applies only to hardware products manufactured by or for Jireh Industries. This warranty does not apply: (a) to damage caused by accident, abuse, misuse, misapplication, or non-Jireh products; (b) to damage caused by service (including upgrades and expansions) performed by anyone who is not a Jireh Authorized Service Provider; (c) to a product or a part that has been modified without the written permission of Jireh.

Jireh Industries Ltd.
53158 Range Rd 224
Ardrossan AB T8E 2K4
Canada
Phone: 780-922-4534
jireh.com

All brands are trademarks or registered trademarks of their respective owners and third-party entities.

Changes or modifications to this unit or accessories not expressly approved by the party responsible for compliance could void the user's authority to operate the equipment.

All specifications are subject to change without notice.

© 2024 Jireh Industries Ltd.



Jireh Industries Ltd.
53158 Range Road 224
Ardrossan, Alberta
Canada
T8E 2K4

780-922-4534

jireh.com