



**■ ROTIX**

CE0205 Rev 00.3  
Chain Corrosion Scanner

---

## SAFETY WARNINGS / PRECAUTIONS

### **KEEP THIS MANUAL – DO NOT LOSE**

THIS MANUAL IS PART OF THE **ROTIX** AND MUST BE RETAINED FOR THE LIFE OF THE PRODUCT. PASS ON TO SUBSEQUENT OWNERS.  
Ensure any amendments are incorporated with this document.



**WARNING!** The **ROTIX** is designed for a specific use. Using the **ROTIX** outside of its intended use could cause damage to the product. Read and understand this manual before using.



**WARNING!** Do **NOT** operate scanner in an explosive environment.  
Do **NOT** operate scanner in the presence of volatile substances.



**WARNING! DO NOT DISASSEMBLE.** No user-serviceable parts. Disassembling any of the components in this product, beyond the instructions in this user manual, could void the regulatory certifications and/or effect the safety of the product.



The **WEEE** symbol indicates that the product must not be disposed of as unsorted municipal waste, but should be collected separately.

(see *Disposal* on page 46)

---

# TABLE OF CONTENTS

<b>1</b>	<b>Identification</b> .....	<b>1</b>
	1.1. Product Brand .....	1
	1.2. Manufacturer .....	1
<b>2</b>	<b>Product Specifications</b> .....	<b>2</b>
	2.1. Base ROTIX Specifications .....	2
	2.1.1. Intended use .....	2
	2.1.2. Dimensions and Weight .....	3
	2.1.3. Environmental Sealing.....	3
	2.1.4. Performance Specifications .....	3
<b>3</b>	<b>Definitions</b> .....	<b>4</b>
	3.1. Definition of Symbols.....	4
	3.2. Definitions of Terms .....	4
<b>4</b>	<b>System Components</b> .....	<b>5</b>
	4.1. Base System Components.....	5
	4.1.1. ROTIX Corrosion Chain Frame .....	5
	4.1.2. J100 Encoder Cable .....	5
	4.1.3. PPS Encoder.....	5
	4.1.4. Heavy Duty Vertical Probe Holder .....	6
	4.1.5. Frame Bar with Ruler .....	6
	4.1.6. Corrosion Scanner Stabilizers .....	6
	4.1.7. QuickLink Components .....	7
	4.1.8. Irrigation Kit .....	8
	4.1.9. Cable Management, Dovetail Mount .....	8
	4.1.10. Tools .....	8
	4.1.11. Case .....	8
	4.2. Compatible Components .....	9
	4.2.1. Encoder Adapter .....	9

4.2.2. Preamp Bracket .....	9
4.3. Tools .....	10
4.3.1. Included Tools .....	10

**5**

**Configuration ..... 11**

5.1. Configurations.....	11
5.1.1. Centre Chain .....	11
5.1.2. Cantilever Chain .....	12
5.2. Corrosion Link and Setup .....	13
5.2.1. Mounting a Frame Bar .....	13
5.2.2. Index Encoder Connection .....	13
5.2.3. Encoder Connection .....	14
5.2.4. Brake .....	14
5.2.5. Wheel Removal/Installation .....	14
5.2.6. QuickLink Tail .....	15
5.3. Carrier .....	16
5.3.1. Index Nuts .....	16
5.3.2. Indexing Latch .....	17
5.3.3. Indexing Plunger .....	18
5.3.4. Carrier Cable Clip .....	18
5.4. Connecting QuickLinks & Dovetail Links .....	19
5.4.1. Connecting QuickLinks .....	19
5.4.2. Disconnecting QuickLinks .....	19
5.4.3. Disconnecting the Dovetail QuickLink .....	20
5.5. Frame Bar with Ruler .....	20
5.6. Heavy Duty Vertical Probe Holder .....	21
5.6.1. Probe Holder Setup .....	21
5.6.2. Probe Holder Vertical Adjustment.....	22
5.6.3. Probe Holder Left/Right Conversion .....	23
5.6.4. Probe Holder 90° Adjustment.....	24
5.7. Pivot Buttons .....	24
5.8. Index Encoder .....	25
5.9. Cable Clips.....	26
5.10. Cable Management System .....	26
5.10.1. Cable Management Dovetail Mount .....	27
5.10.2. Cable Management Setup .....	27
5.10.3. Clamp Setup .....	28
5.11. Preamp Bracket .....	29
5.11.1. Mounting Preamp Bracket .....	29
5.11.2. Attaching Preamp with Screws .....	29

- 6** Operation .....31
  - 6.1. Setup of ROTIX on a Scanning Surface .....31
- 7** Maintenance .....35
- 8** Troubleshooting .....36
  - 8.1. Technical Support .....36
- 9** Service and Repair .....37
- 10** Spare Parts .....38
  - 10.1. Corrosion Scanner .....38
  - 10.2.Kit Components.....40
    - 10.2.1. ROTIX Corrosion Case .....41
    - 10.2.2. Encoder Connector Type .....41
    - 10.2.3. Cable Management, Dovetail Mount .....42
  - 10.3.Accessories .....43
    - 10.3.1. Preamp Bracket .....43
    - 10.3.2. HydroFORM™ Cart .....43
  - 10.4.Heavy Duty Vertical Probe Holder .....44
  - 10.5.Probe Holder Components .....45
    - 10.5.1. Heavy Duty Yoke Style .....45
    - 10.5.2. Pivot Button Style .....45
- 11** Disposal .....46
- 12** Limited Warranty .....47
- 13** Appendix.....49
  - 13.1. Chain Configuration Setup Chart .....49

# IDENTIFICATION

## 1.1. Product Brand

This user manual describes the proper safety precautions, setup and use of the **ROTIX** scanner.

## 1.2. Manufacturer

Distributor:

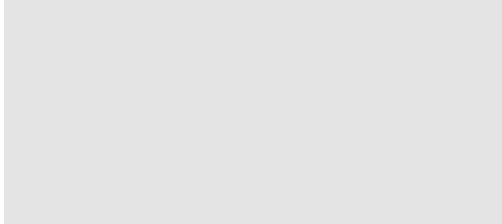

Manufacturer:

Jireh Industries Ltd.  
53158 Range Road 224  
Ardrossan, Alberta, Canada  
T8E 2K4  
Phone: 780.922.4534  
jireh.com

# PRODUCT SPECIFICATIONS

## 2.1. Base ROTIX Specifications

### 2.1.1. Intended use

The **ROTIX** chain scanner is a manually operated scanner which provides indexed corrosion scanning.

#### 2.1.1.1 Operating Limits

Category	Parameter	Specification
Inspection Surface	Minimum OD, external circumferential pipe/tube range	10.2 cm (4 in)
	Maximum OD, external circumferential pipe/tube range	96.5 cm (38 in)
Scanner	Radial scanner clearance	13.1 cm (5.14 in)
	Stroke length	61 cm (24 in)

#### 2.1.1.2 Operating environment

The **ROTIX** chain scanner is designed for use in an industrial environment that is between -20°C (-4°F) and 50°C (122°F).

## 2.1.2. Dimensions and Weight

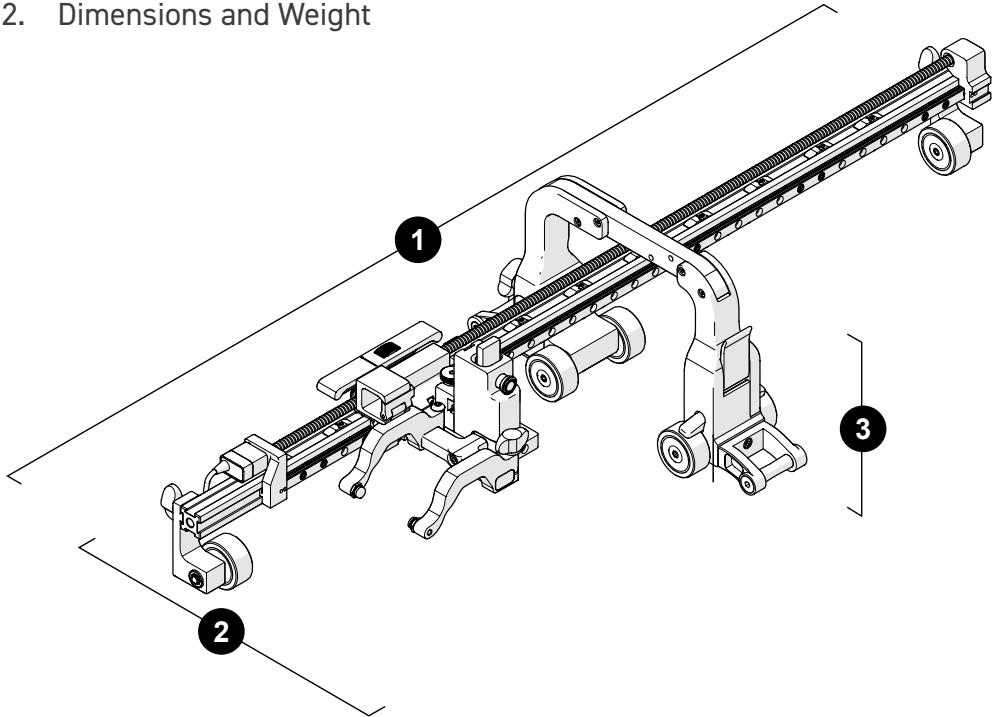

Fig. 1 - Dimensions

1:	Scanner width	75 cm	(29.5 in)
2:	Scanner depth	27.8 cm	(11 in)
3:	Scanner height	15.1 cm	(5.9 in)
	Frame weight	2.8 kg	(6.2 lb)
	Encoder cable length	7.5 m	(24.6 ft)

## 2.1.3. Environmental Sealing

Dust-tight, watertight (*not submersible*).

## 2.1.4. Performance Specifications

Category	Specification
Scan encoder resolution	16.3 counts/mm (414.5 counts/inch)
Index encoder resolution	40.3 counts/mm (1023.9 counts/inch)



# DEFINITIONS

## 3.1. Definition of Symbols



Instructions to 'look here' or to 'see this part.'

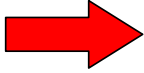

Denotes movement. Instructing users to carry out an action in a specified direction.

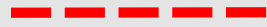

Indicates alignment axis.



Alerts user that the view has changed to a reverse angle.

## 3.2. Definitions of Terms

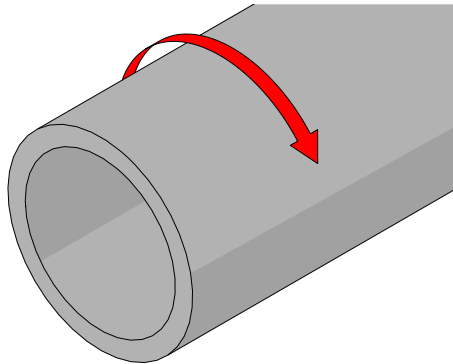

Fig. 2 - Circumferential scanning

**Circumferential**

Direction of scan travel is around the circumference of the pipe/tube (*Fig. 2*).

## SYSTEM COMPONENTS

### 4.1. Base System Components

#### 4.1.1. ROTIX Corrosion Chain Frame CEA042-

The corrosion chain frame includes the system braking and an internal positional encoder.

The slider system allows positioning of a probe holder.

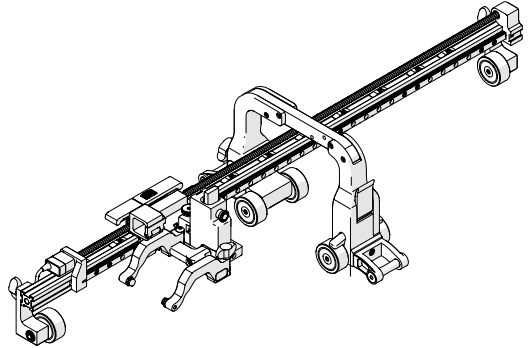

Fig. 3 - Corrosion chain frame

#### 4.1.2. J100 Encoder Cable UMA026-

The encoder cable connects the ROTIX system to the user's instrument. (Fig. 4).

Various encoder cable styles are available for various instruments.

**NOTE:** *Inspect the cable and connectors for damage before use. When damage is evident, the cable must **NOT** be used.*

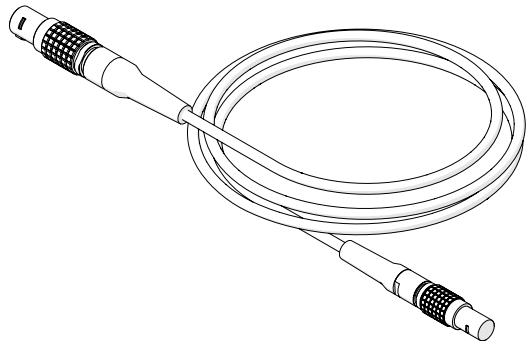

Fig. 4 - J100 Encoder cable

#### 4.1.3. PPS Encoder DKS009-

The PPS Encoder offers the capability of two-axis encoding on the ROTIX chain scanner (Fig. 5).

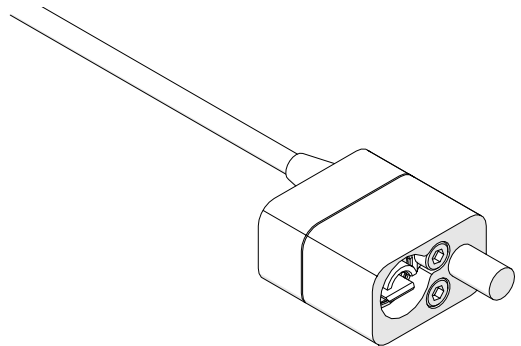

Fig. 5 - PPS encoder

#### 4.1.4. Heavy Duty Vertical Probe Holder PHS043-

The heavy duty vertical probe holder is designed to carry larger probes. Available with various arm, yoke and pivot buttons, the heavy duty vertical probe holder exerts more downforce on a large footprint probe/wedge (Fig. 6).

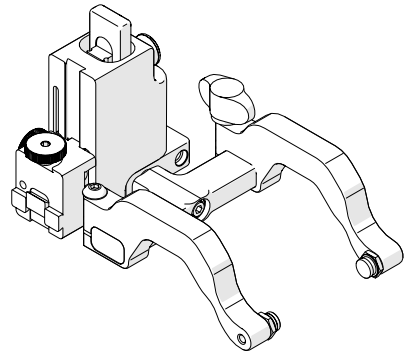

Fig. 6 - Heavy duty vertical probe holder

#### 4.1.5. Frame Bar with Ruler BG0090-

Frame bars are used to mount probe holders, probe positioning systems and other accessories. The frame bar includes a ruler with 1 mm measurements. The ruler can be used to assist with the positioning of index nuts (Fig. 7).

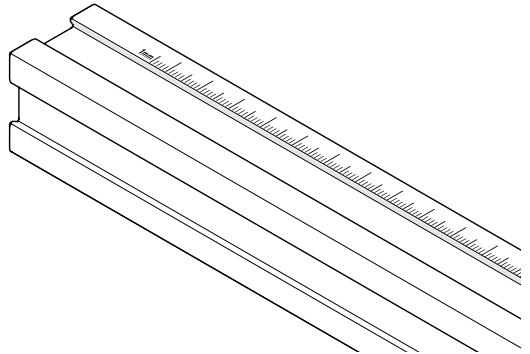

Fig. 7 - Frame bar with ruler

#### 4.1.6. Corrosion Scanner Stabilizers CES053-

Two corrosion scanner stabilizers are included to maintain balance of the system when mounted on a pipe (Fig. 8).

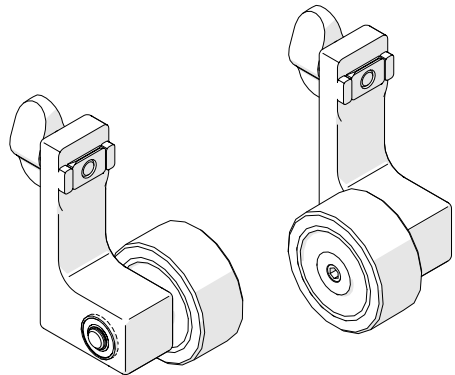

Fig. 8 - Corrosion scanner stabilizers

## 4.1.7. QuickLink Components

The QuickLink components fasten a **ROTIX** system circumferentially around a pipe or tube.

### 4.1.7.1 QuickLink EES004

QuickLinks connect to assemble the required length to mount the system on a pipe (Fig. 9).

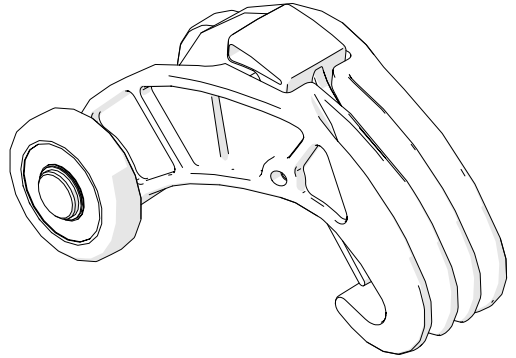

Fig. 9 - QuickLink

### 4.1.7.2 Dovetail QuickLink EES019

The Dovetail QuickLink connects to QuickLinks, providing a mounting point for accessories such as cable management (Fig. 10).

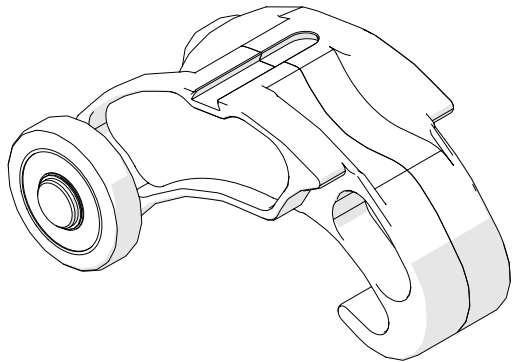

Fig. 10 - Dovetail QuickLink

### 4.1.7.3 QuickLink Buckle EES014

The QuickLink Buckle enables adjustment of the chain tension and provides the connection point of the QuickLinks assembly (Fig. 11).

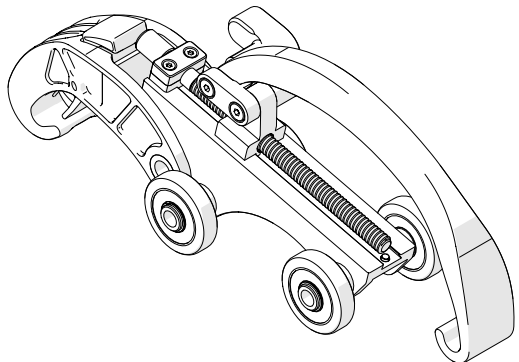

Fig. 11 - QuickLink Buckle

#### 4.1.8. Irrigation Kit CMG007

The irrigation kit provides a variety of hoses, fittings, connectors, and splitters commonly used during non-destructive inspection (*Fig. 12*).

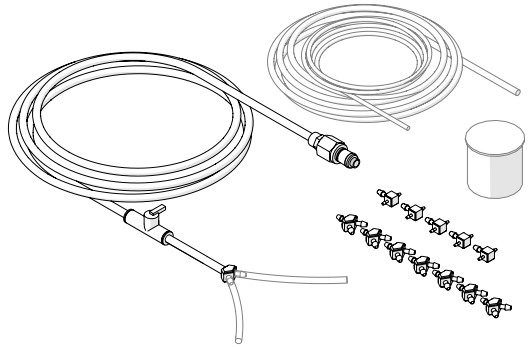

Fig. 12 - Irrigation kit

#### 4.1.9. Cable Management, Dovetail Mount CES044-

The cable management provides a means of protecting and organizing cables, tubes and hoses. The dovetail mount connects to the Dovetail QuickLink (*Fig. 13*).

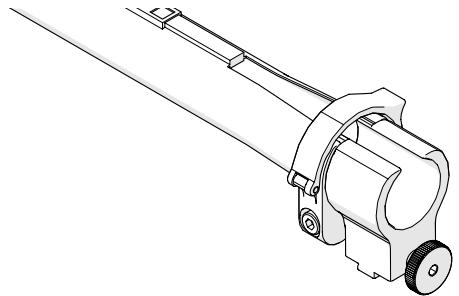

Fig. 13 - Cable management, dovetail mount

#### 4.1.10. Tools

Several tools are included for various scanner and accessory adjustments. (*see Tools on page 10*).

#### 4.1.11. Case

The system is provided with a rugged carrying case.

## 4.2. Compatible Components

### 4.2.1. Encoder Adapter UMA010-

Adapt a scanner's existing encoder connector to a different encoder style (Fig. 14).

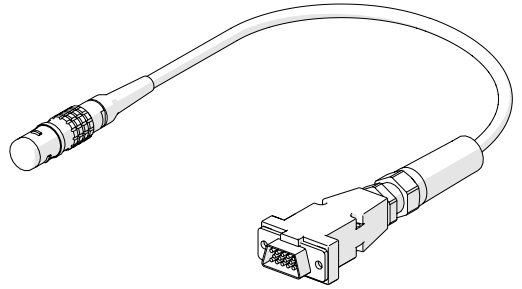

Fig. 14 - Encoder adapter

### 4.2.2. Preamp Bracket CES029-

A bracket that mounts to a scanner to hold various preamps (Fig. 15).

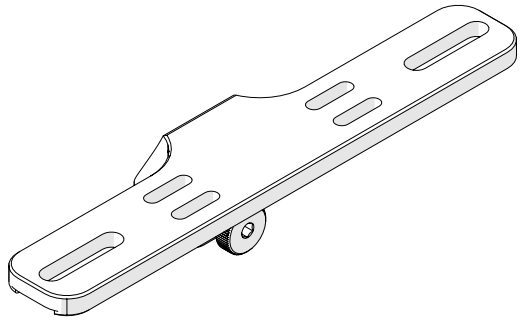

Fig. 15 - Preamp bracket

## 4.3. Tools

### 4.3.1. Included Tools

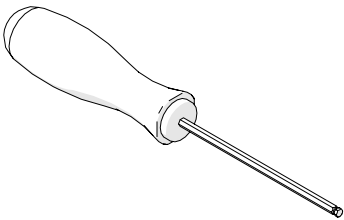

Fig. 16 - 3 mm hex driver

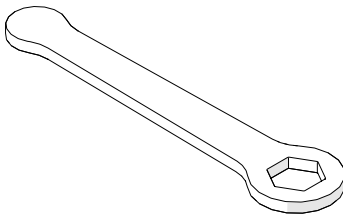

Fig. 17 - 3/8 in wrench

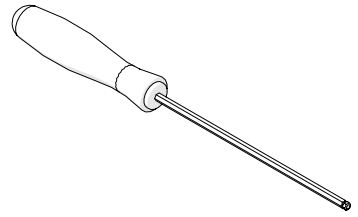

Fig. 18 - 2 mm hex driver

- ▶ The 3 mm hex driver is sufficient for all typical operations and adjustments. (Fig. 16).
- ▶ The 3/8 in wrench removes, and installs pivot buttons on the probe holders (Fig. 17).
- ▶ The 2 mm hex driver adjusts the index nuts (Fig. 18).
- ▶ The short 2 mm hex wrench may adjust the index nuts along the frame bar (Fig. 19).

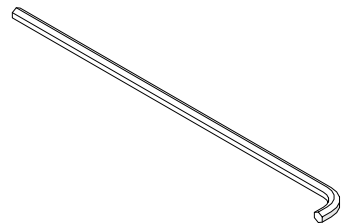

Fig. 19 - Short 2 mm hex wrench

# CONFIGURATION

## 5.1. Configurations

### 5.1.1. Centre Chain

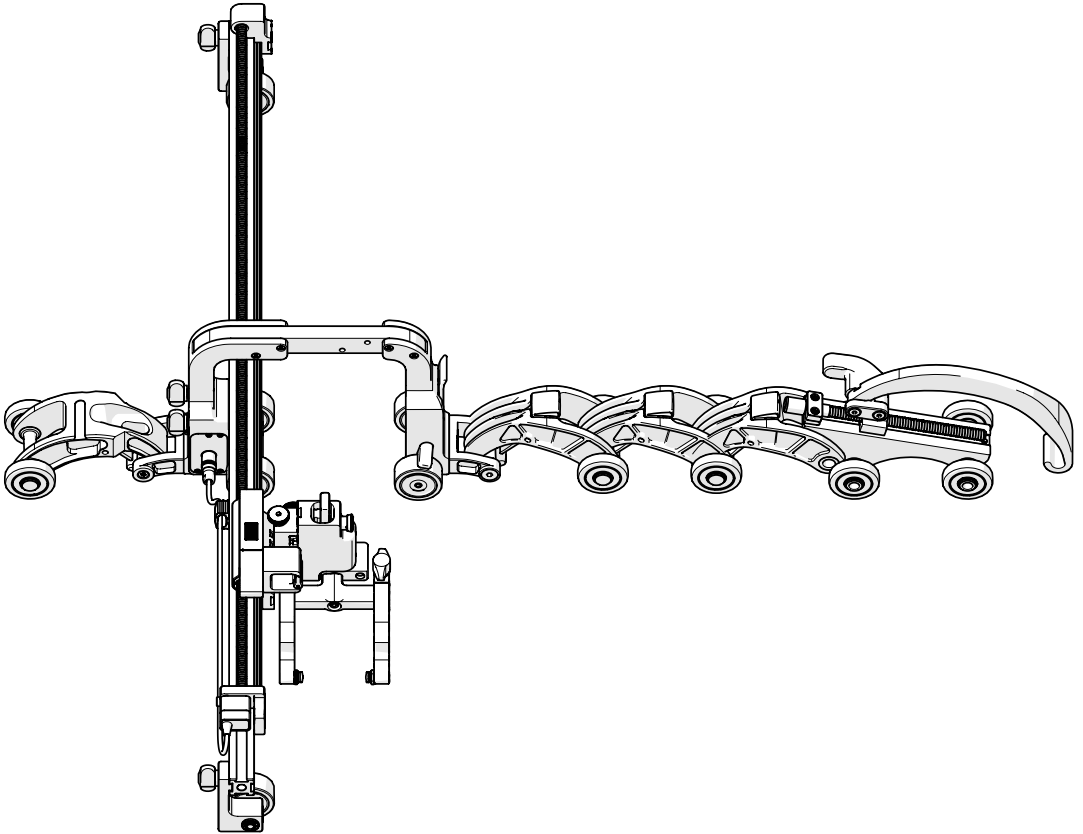

Fig. 20 - Centre chain configuration



## 5.1.2. Cantilever Chain

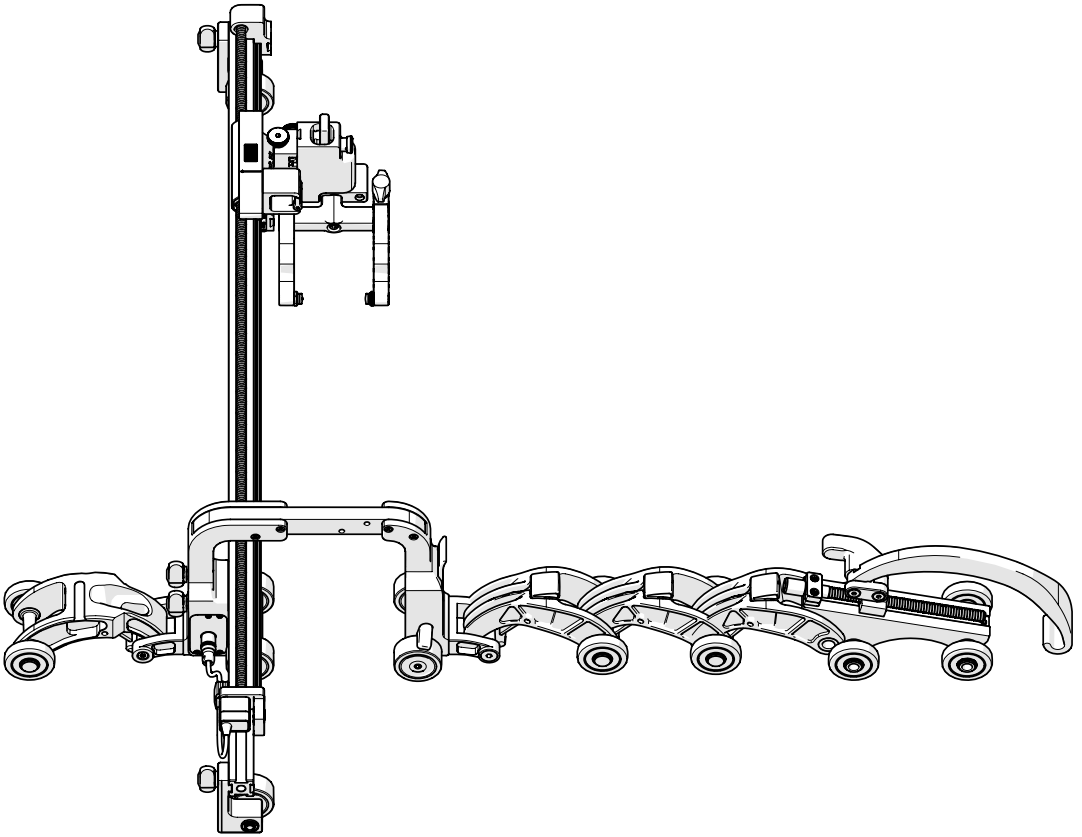

Fig. 21 - Cantilever chain configuration

## 5.2. Corrosion Link and Setup

### 5.2.1. Mounting a Frame Bar

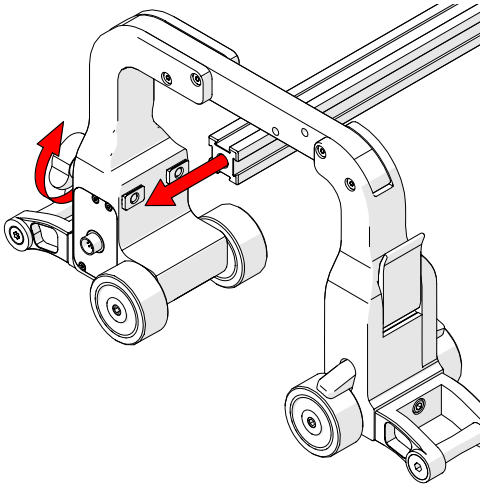

Fig. 22 - Loosen wing knobs

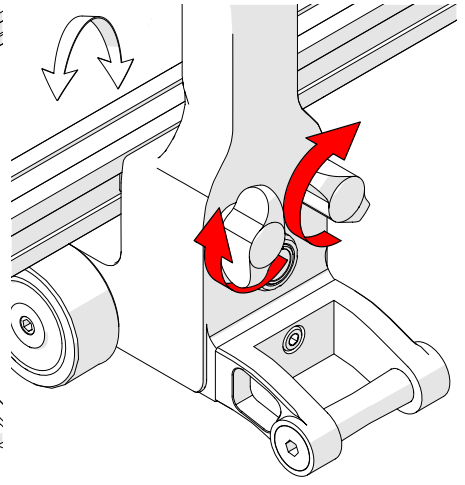

Fig. 23 - Tighten wing knobs

Loosen the two black wing knobs of the corrosion link (Fig. 22). Slide the frame bar along the dovetail nuts of the corrosion link (Fig. 22). When the frame bar is positioned where appropriate, tighten the two black wing knobs (Fig. 23).

### 5.2.2. Index Encoder Connection

The index encoder connection (Fig. 24) is located along the side of the corrosion link. The cable from the index encoder (see *Index Encoder* on page 25) connects to this point.

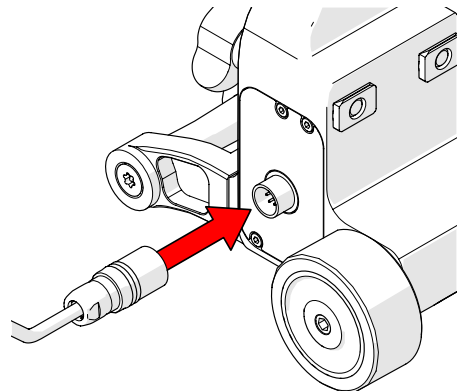

Fig. 24 - Index encoder connection

### 5.2.3. Encoder Connection

The encoder cable connects to the encoder connection at the rear of the corrosion link (Fig. 25). The opposite end of the encoder cable connects to the user's instrument.

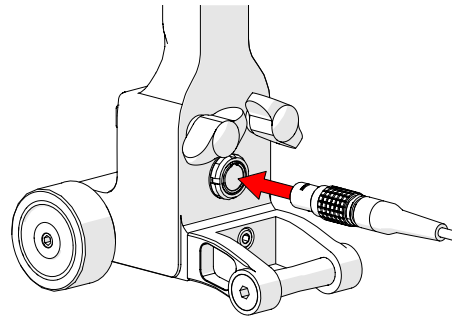

Fig. 25 - Encoder connection

### 5.2.4. Brake

The red brake lever (Fig. 26) located on the corrosion link provides braking to the system. Press the lever down to activate the brake.

**TIP:** When the brake is engaged and the scanner is moved, this may loosen the wheels from the axle. Grip the wheel tightly and retighten the axle with the 3 mm hex driver.

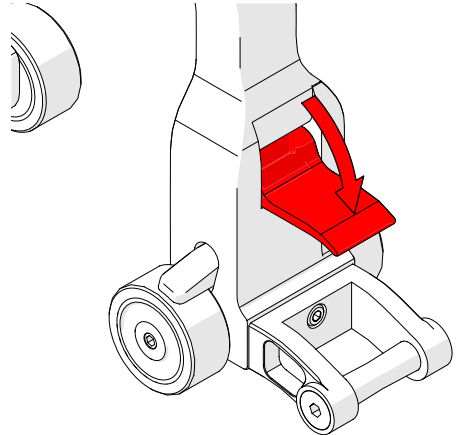

Fig. 26 - Brake

### 5.2.5. Wheel Removal/Installation

#### 5.2.5.1 Removal

Tightly grip the wheel to be removed by hand. Insert the provided 3 mm hex driver in the shaft of the wheel to be removed (Fig. 16), and unthread the wheel from the axle (Fig. 27).

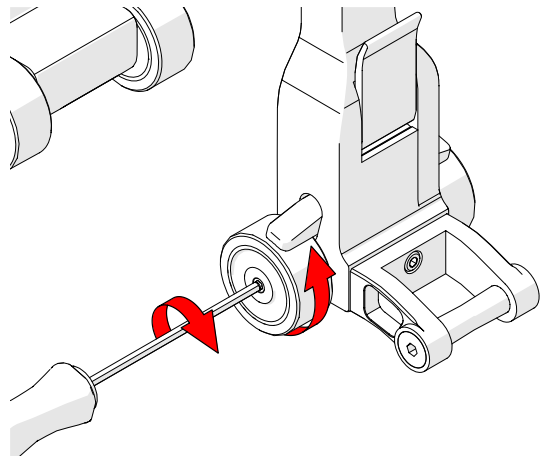

Fig. 27 - Removing wheels

### 5.2.5.2 Installation

Press the wheel on the axle and insert the 3 mm hex driver in the shaft while threading the wheel to the axle (Fig. 27).

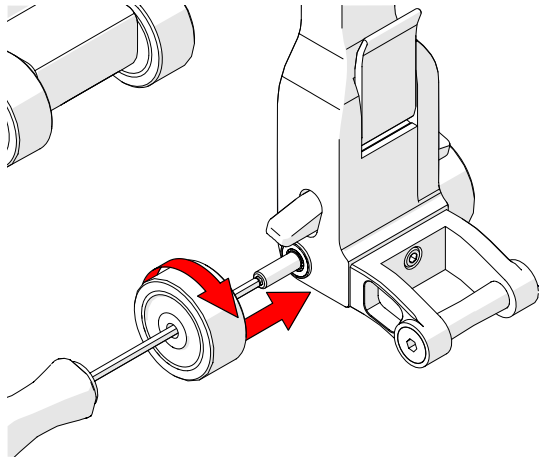

Fig. 28 - Installing wheels

### 5.2.6. QuickLink Tail

Located at both ends of the corrosion link, a QuickLink Tail (Fig. 29) is a mounting point for QuickLinks.

Use the supplied 3 mm hex driver to install or remove the tail.

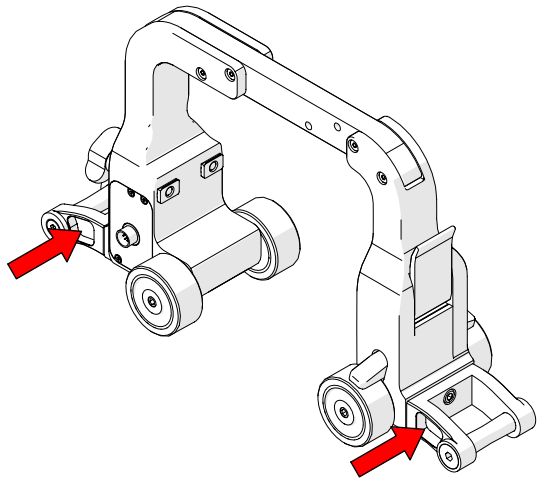

Fig. 29 - QuickLink tail

## 5.3. Carrier

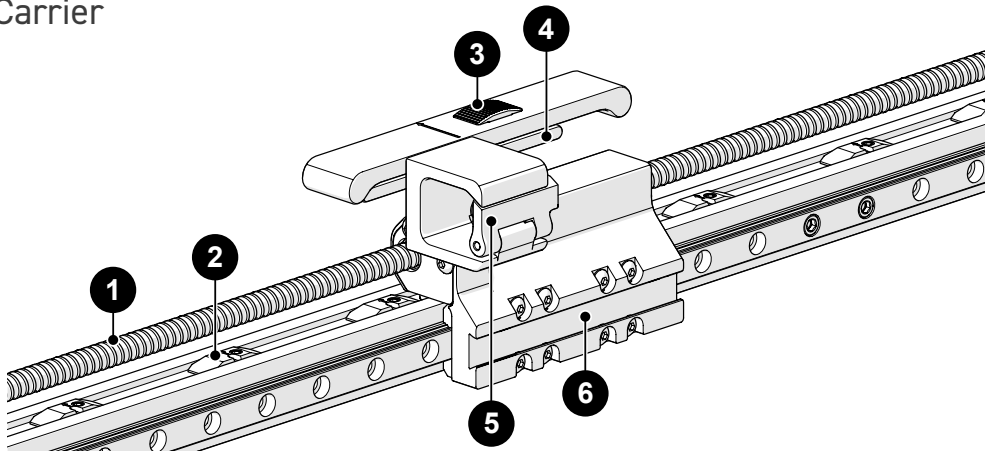

Fig. 30 - Carrier identification

With the use of a leadscrew, the carrier can move along the length of the frame bar.

1	Leadscrew	4	Indexing plunger
2	Index nut	5	Carrier cable clip
3	Indexing latch	6	Probe holder dovetail

### 5.3.1. Index Nuts

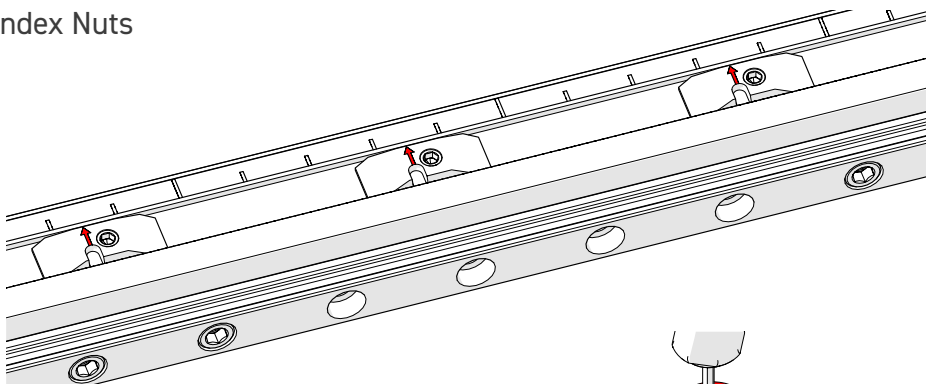

Fig. 31 - Index nuts

The index nuts (*Fig. 31*), located along the frame bar, offer index positions during scans. The arrow on each nut confirms alignment with the ruler on the frame bar.

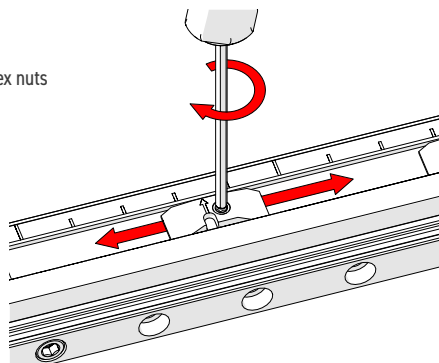

Fig. 32 - Position index nuts

**NOTE:** The index nuts can be repositioned. Placement of the index nuts works in conjunction with common probe specifications. Adjustment of the index nuts is not recommended.

The manufacturer configures the index nuts with a spacing of 58 mm (2.28 in). The spacing at the end of the scanner's final position is 48 mm (1.89 in).

### 5.3.2. Indexing Latch

The indexing latch toggles between stopping the carrier at each index nut or sliding freely.

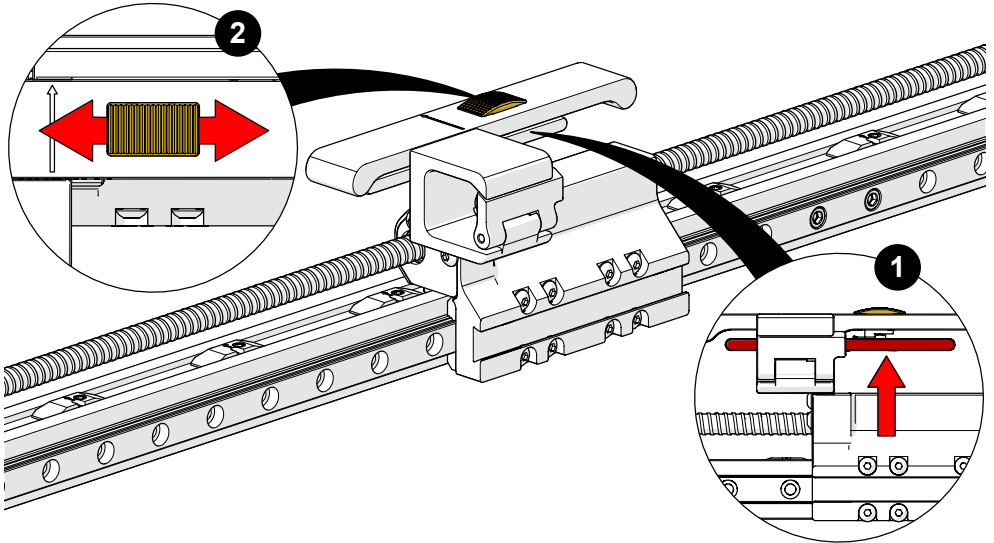

Fig. 33 - Carrier indexing latch

1. Lift the **1** indexing plunger and move the **2** indexing latch to the left to permanently disengage the indexing plunger (Fig. 34). This will allow the carrier to move freely along the leadscrew (Fig. 35).
2. Lift the **1** indexing plunger and move the **2** indexing latch to the right to activate the indexing plunger (see *Indexing Plunger* on page 18 for additional details).

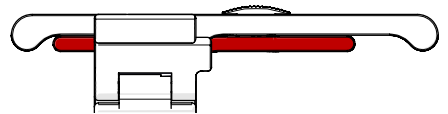

Fig. 34 - Indexing plunger disengaged

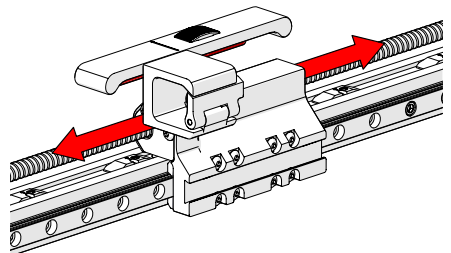

Fig. 35 - Carrier moves freely

### 5.3.3. Indexing Plunger

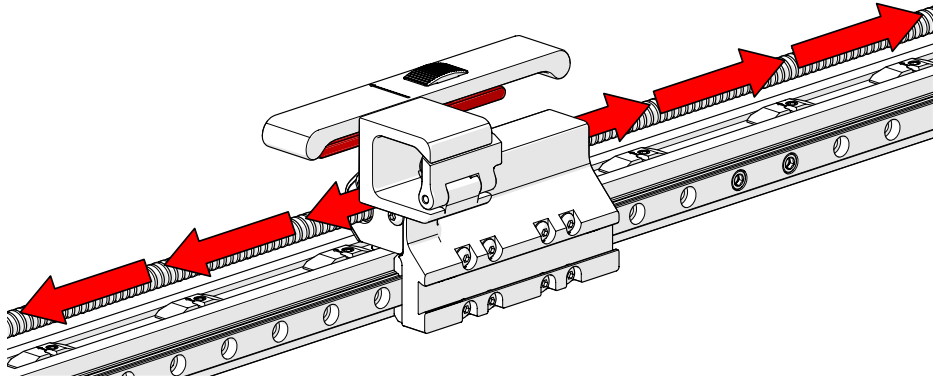

Fig. 36 - Indexing plunger

1. Lift the indexing plunger and move the carrier slightly to release the carrier from the locked position. Lower the indexing plunger and slide the carrier to the next index location where the carrier will lock in position (Fig. 36).

### 5.3.4. Carrier Cable Clip

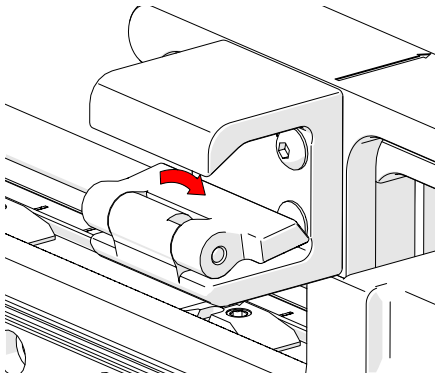

Fig. 37 - Carrier cable clip flap

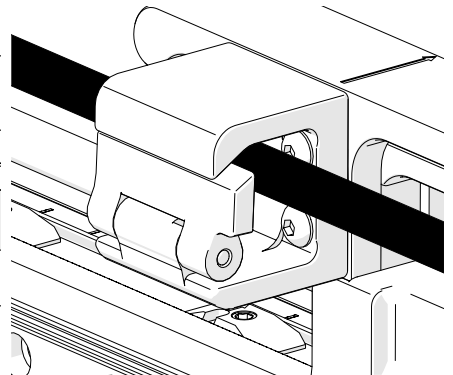

Fig. 38 - Carrier cable clip

1. Push the cable clip flap down (Fig. 37) and insert the cables and hoses (Fig. 38).

## 5.4. Connecting QuickLinks & Dovetail Links

### 5.4.1. Connecting QuickLinks

To connect QuickLinks, see the following steps:

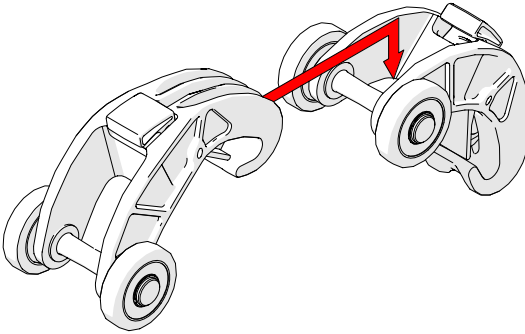

Fig. 39 - Lift the hook over the axle of the QuickLink

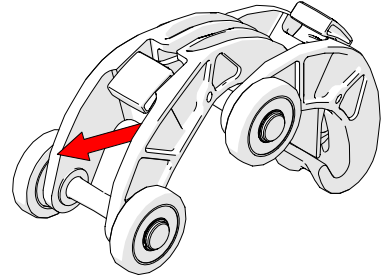

Fig. 40 - Pull the link backwards to secure catch

1. Lift the hook of the QuickLink over the axle of the QuickLink that is to be connected (Fig. 39).
2. Pull the QuickLink until you hear a click that ensures the latch has been set (Fig. 40).

### 5.4.2. Disconnecting QuickLinks

To disconnect QuickLinks, see the following steps:

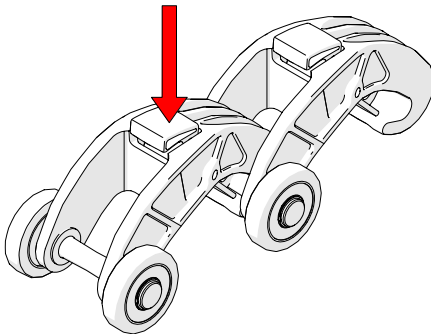

Fig. 41 - Press button

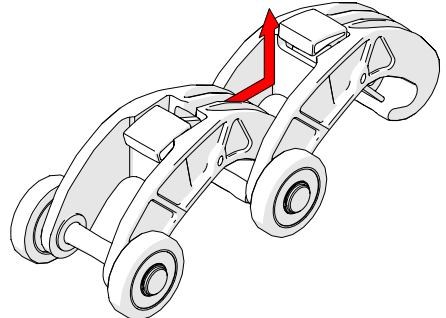

Fig. 42 - Slide QuickLink forward and lift

1. Press the button on the top of the QuickLink (Fig. 41).
2. While pressing the button, slide the QuickLink forward and up, clearing the hook of the QuickLink from the 2<sup>nd</sup> QuickLink's axle (Fig. 42).



### 5.4.3. Disconnecting the Dovetail QuickLink

To disconnect Dovetail QuickLinks, see the following steps:

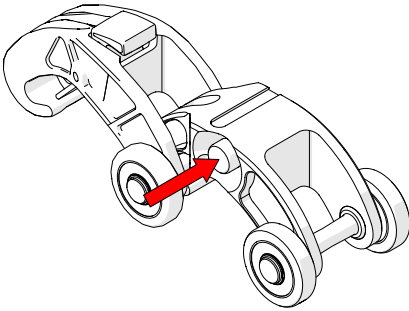

Fig. 43 - Press red button

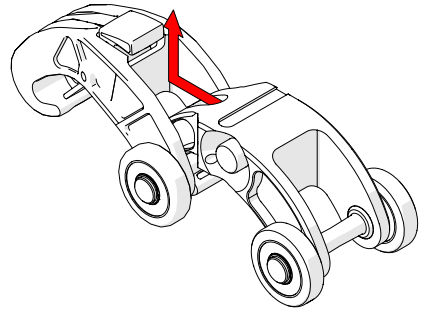

Fig. 44 - Slide Dovetail QuickLink forward and lift

1. Press the button on the side of the Dovetail QuickLink (Fig. 43).
2. While pressing the red button, slide the Dovetail QuickLink forward and up, clearing the hook of the Dovetail QuickLink from the 2<sup>nd</sup> QuickLink's axle (Fig. 44).

### 5.5. Frame Bar with Ruler

Frame bars (Fig. 45) are used to mount probe holders, probe positioning systems and other accessories. The frame bar includes a ruler with 1 mm measurements. The ruler can be used to assist with the positioning of index nuts.

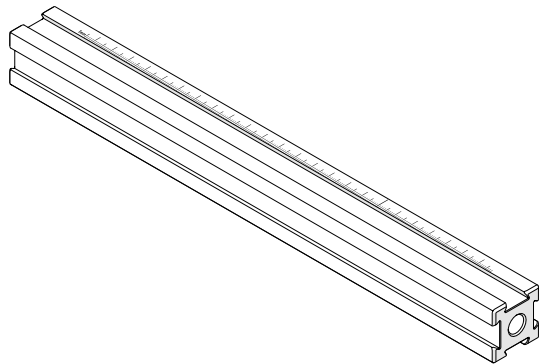

Fig. 45 - Frame bar with ruler

## 5.6. Heavy Duty Vertical Probe Holder

- A Latch
- B Probe Holder Arm Adjustment Knob
- C Yoke
- D Probe Holder Arms
- E Pivot Buttons
- F Arm Clamp Screw
- G Probe Holder Adjustment Knob
- H Vertical Adjustment Knob

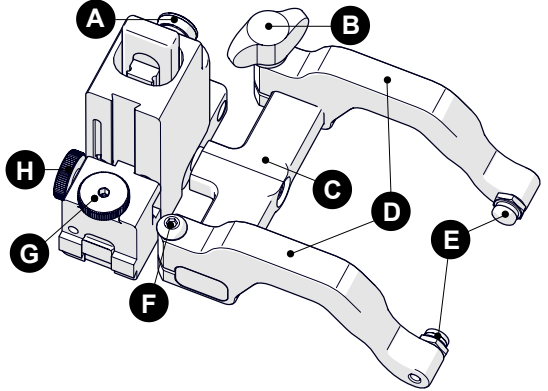

Fig. 46 - Heavy duty vertical probe holder

### 5.6.1. Probe Holder Setup

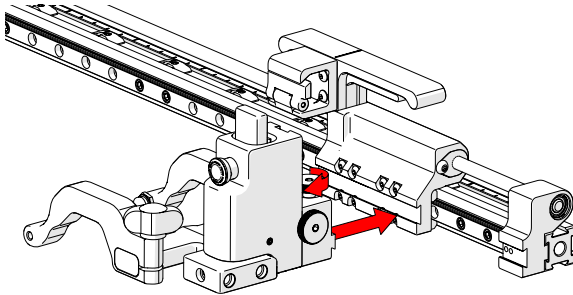

Fig. 47 - Mount probe holder to carrier

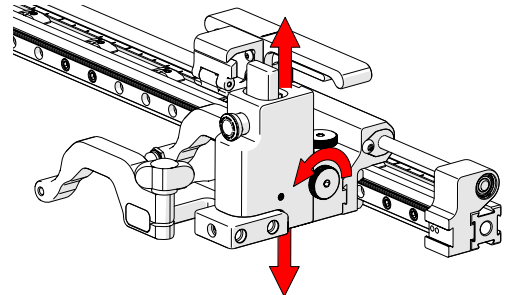

Fig. 48 - Vertical adjustment

1. Loosen the probe holder adjustment knob (*Fig. 47*) and mount the heavy duty vertical probe holder's dovetail jaw to the carrier.
2. The vertical adjustment knob (*Fig. 48*) allows height adjustment of the heavy duty vertical probe holder. This adjustment also controls the probe holder's spring tension.

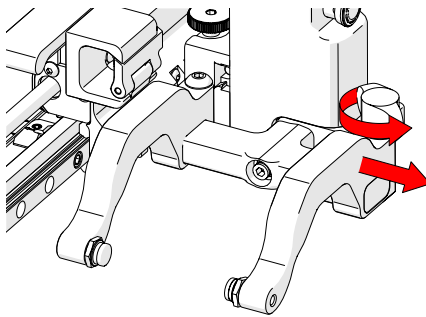

Fig. 49 - Remove outer arm

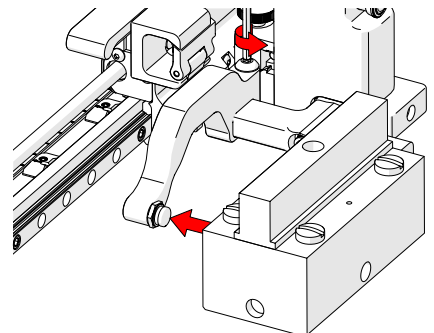

Fig. 50 - Adjust inner arm

- Loosen the probe holder adjustment knob and remove the outer probe holder arm (Fig. 49).
- Loosen the arm clamp screw (Fig. 50).
- Place the wedge on the pivot button of the inner probe holder arm (Fig. 50).

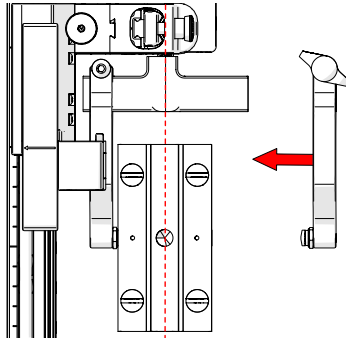

Fig. 51 - Remove outer arm

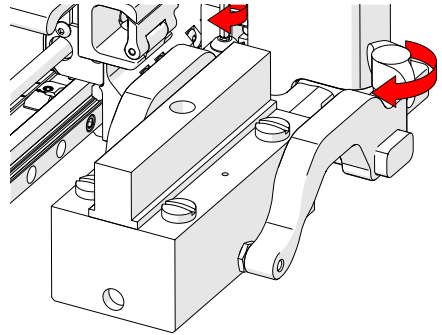

Fig. 52 - Pivot buttons

- Align the middle of the wedge with the centre of the yoke (Fig. 51).
- Tighten the probe holder adjustment knob and the arm clamp screw (Fig. 52) while ensuring the wedge remains centred with the yoke.

## 5.6.2. Probe Holder Vertical Adjustment

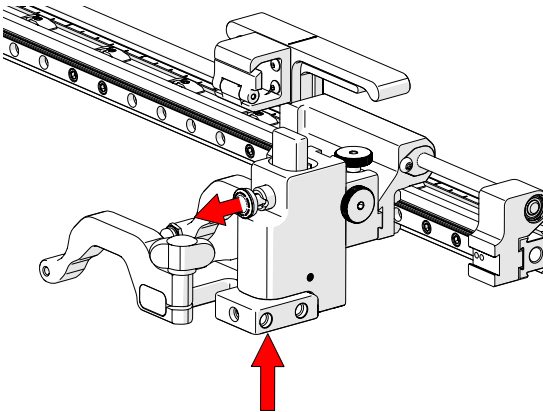

Fig. 53 - Press up and pull latch

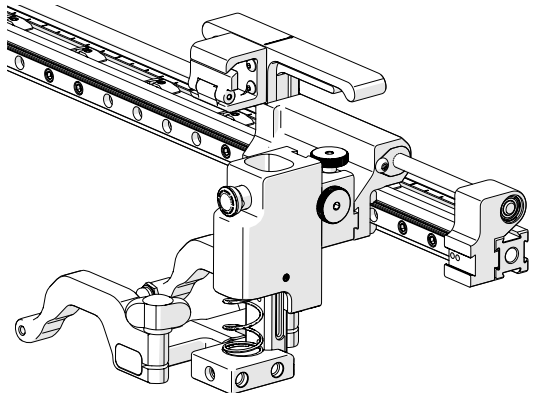

Fig. 54 - Lowered toward scan surface

- Gently lift the heavy duty vertical probe holder and simultaneously pull the latch (Fig. 53). This action will unlock the probe holder. Slowly lower the probe holder towards the scan surface (Fig. 54).

### 5.6.3. Probe Holder Left/Right Conversion

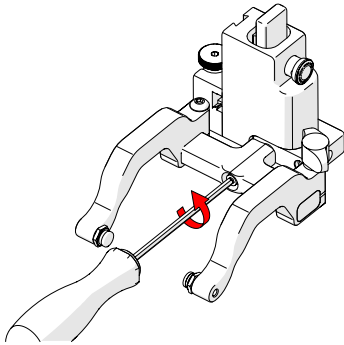

Fig. 55 - Remove yoke

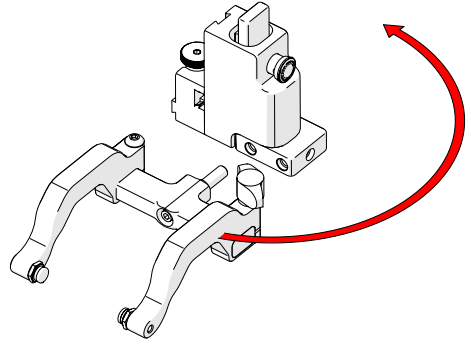

Fig. 56 - Orient to opposite side

1. Using the supplied 3 mm driver, unscrew the yoke (Fig. 55).
2. Position the yoke and arms to the opposite side of the probe holder (Fig. 56).

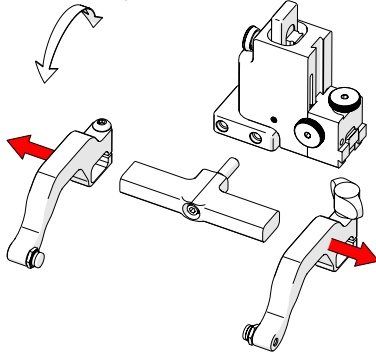

Fig. 57 - Remove probe holder arms

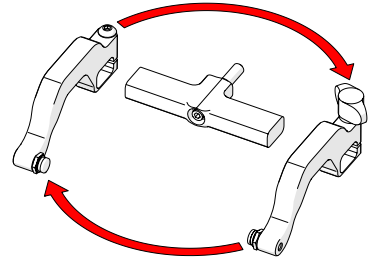

Fig. 58 - Reverse position around yoke

3. Loosen the arm clamp screw and the probe holder arm adjustment knob allowing the removal of the probe holder arms (Fig. 57).
4. Position the removed arms to the opposite sides of the yoke (Fig. 58).

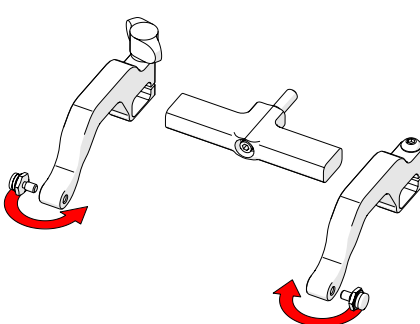

Fig. 59 - Position pivot buttons

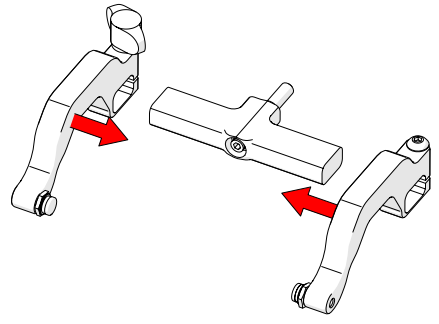

Fig. 60 - Place arms back onto yoke

5. Position the pivot buttons to the inside of the probe holder arms (Fig. 59).
6. Place the probe holder arms on the yoke and tighten the arm clamp screw and probe holder adjustment knob (Fig. 60).
7. Screw the yoke to the probe holder (Fig. 61).

**TIP:** Position the yoke in the threaded hole closest to the frame bar when using a standard yoke length. Position the yoke in the threaded hole furthest from the frame bar when using a wide yoke length.

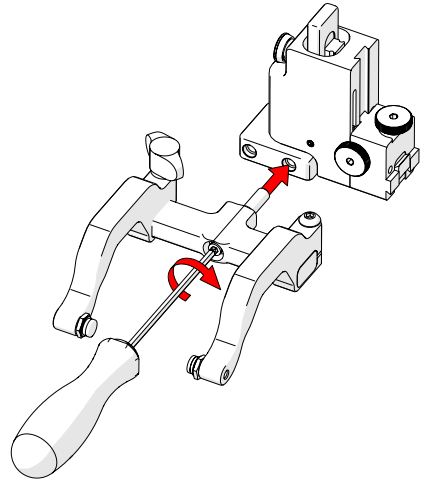

Fig. 61 - Screw into threaded hole

#### 5.6.4. Probe Holder 90° Adjustment

1. Remove the yoke using the supplied 3 mm hex driver (Fig. 55).
2. Orient the yoke to the front of the probe holder and screw the yoke into the threaded hole provided (Fig. 62).

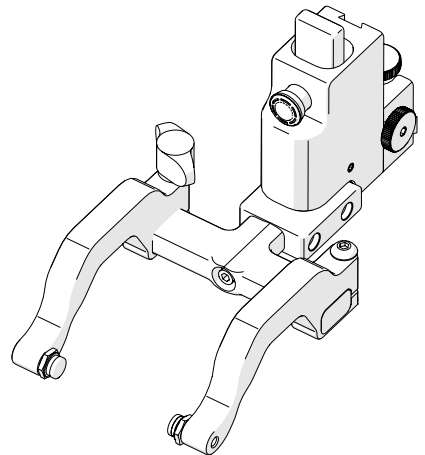

Fig. 62 - 90° probe holder positioning

#### 5.7. Pivot Buttons

Available in a variety of shapes and sizes, fitting various wedge dimensions.

Use the supplied 3/8 in wrench (Fig. 17) to remove and install pivot buttons (Fig. 63).

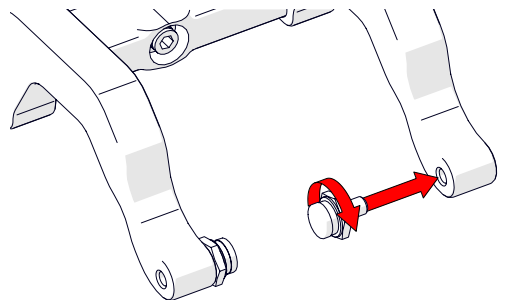

Fig. 63 - Pivot buttons

## 5.8. Index Encoder

The index encoder provides positional feedback perpendicular to the scan direction of travel.

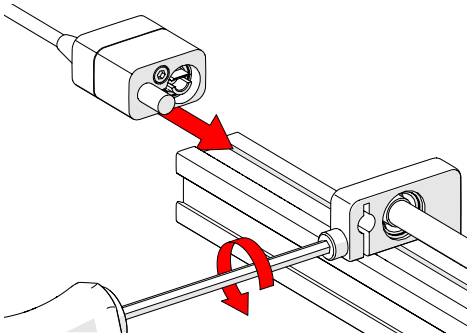

Fig. 64 - Loosen and slide post in place

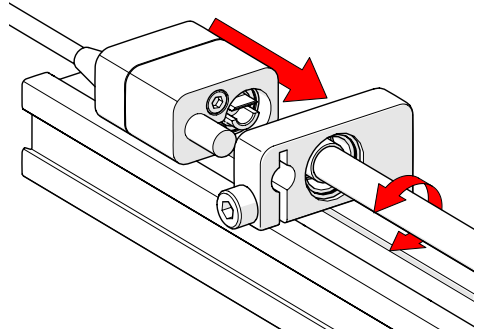

Fig. 65 - Align and mount post

1. To install the index encoder, loosen the clamp screw on the encoder with the supplied 3 mm hex driver (Fig. 64).
2. Insert the encoder post in the index encoder support bracket while aligning the leadscrew shaft with the encoder socket (Fig. 65).

**TIP:** You can rotate the leadscrew by hand to assist in the alignment of the encoder socket.

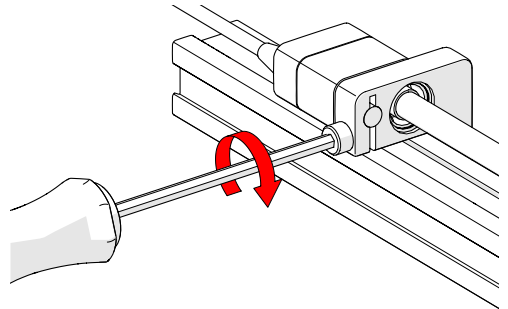

Fig. 66 - Tighten clamp screw

3. Tightening the 3 mm clamp screw on the index encoder support bracket (Fig. 66).
4. Route the cable along the frame bar using the cable clips. Plug the encoder end into the index encoder connection on the side of the corrosion link (Fig. 67).

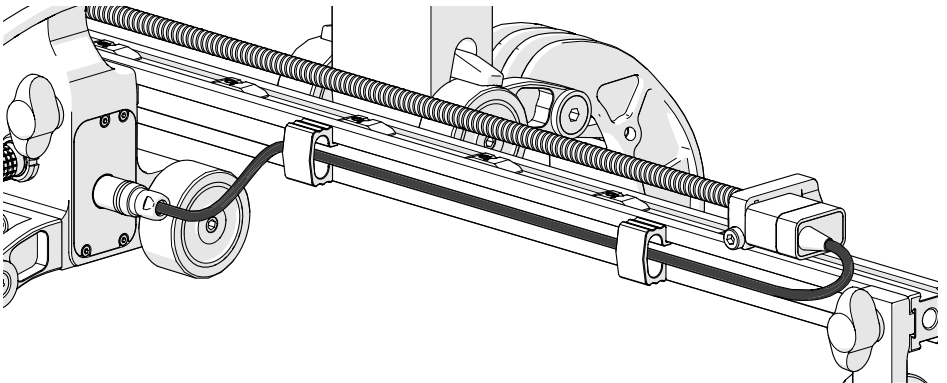

Fig. 67 - Connect index encoder to index encoder connection

## 5.9. Cable Clips

Clips have been provided to assist with cable management. Pinch the clip and press it into the dovetail groove of the frame bar.

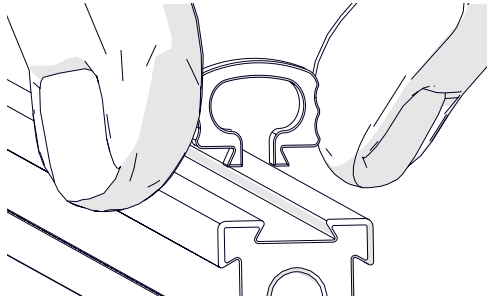

Fig. 68 - Pinch clip

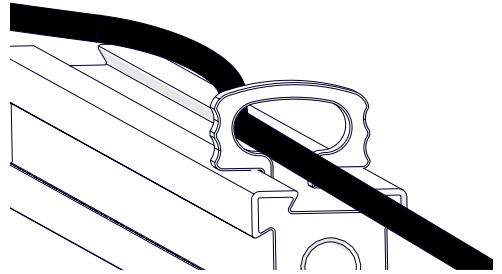

Fig. 69 - Route cables

## 5.10. Cable Management System

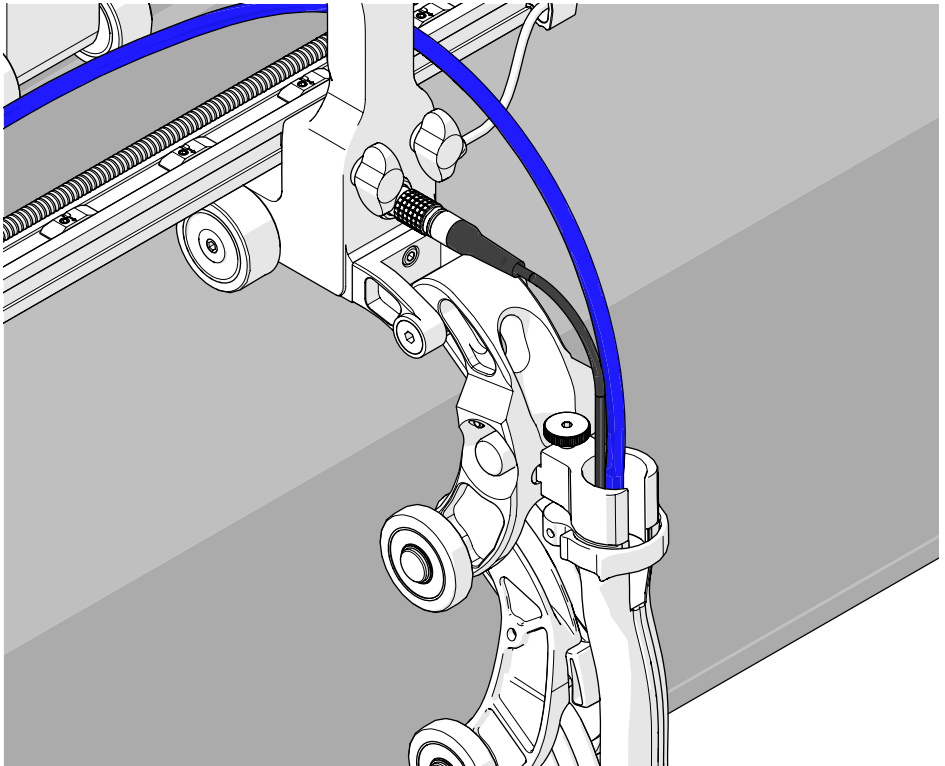

Fig. 70 - Cable management

**TIP:** When using cable management, ensure the dovetail link is placed directly behind the corrosion link.

### 5.10.1. Cable Management Dovetail Mount

To attach cable management, follow these steps:

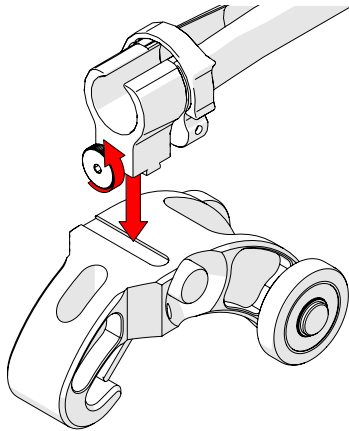

Fig. 71 - Loosen and slide on

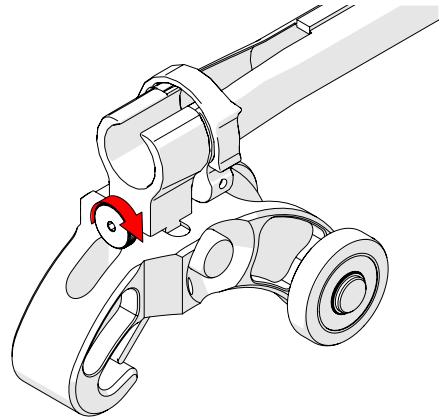

Fig. 72 - Tighten knob

1. Loosen the knob on the cable management dovetail mount. Position the mount onto the Dovetail QuickLink (Fig. 71).
2. Once centred on the Dovetail QuickLink, tighten the cable management's dovetail mount knob (Fig. 72).

### 5.10.2. Cable Management Setup

The cable management is offered in a variety of lengths and provides a means of bundling and protecting cables and hoses that run to the scanner.

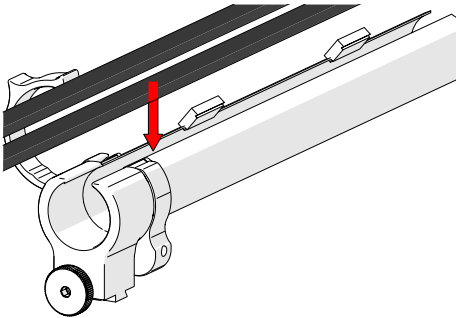

Fig. 73 - Insert cables and hoses

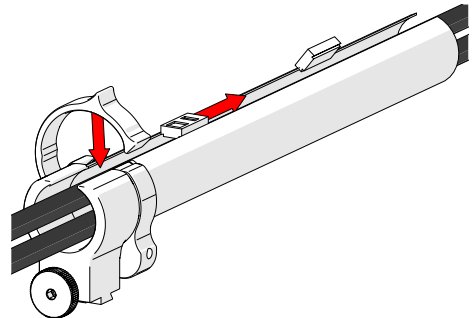

Fig. 74 - Zip up to close

1. Open the cable management and cable latch. Begin at the tube's dovetail mount and place the cabling in the tube (Fig. 73).
2. Follow the cable placement, zipping the tube closed and closing the cable management's cable clip (Fig. 74).



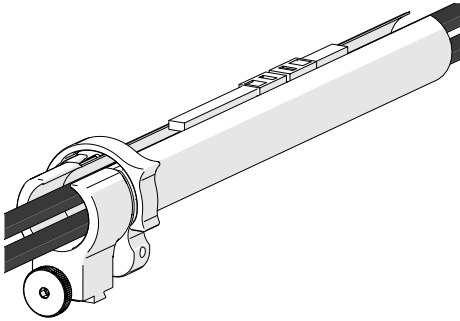

Fig. 75 - Zip opposite end

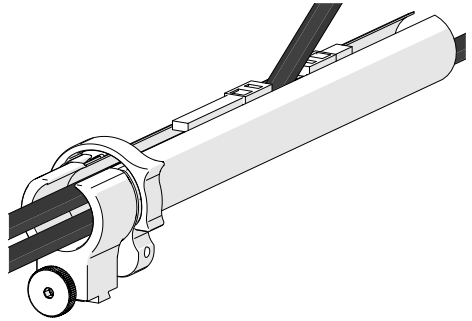

Fig. 76 - Flexibility

3. Once the cable is placed the entire length of the tube, bring the zipper from the tube's opposite end, meeting at any point in the middle (Fig. 75).
4. When necessary, the two zippers may be opened to allow cables to exit the tube anywhere between the ends (Fig. 76).

### 5.10.3. Clamp Setup

If the tube becomes disconnected from the cable management dovetail mount, follow these instructions to re-attach the tube and dovetail mount.

1. Loosen the clamp screw using the supplied 3 mm hex driver.
2. Slide the clamp around the tube first and then slide the tube around the outside of the cable management dovetail mount (Fig. 77). Align the zipper opening and the cable management dovetail mount opening.
3. Slide the clamp over the tube and cable management dovetail mount, pinching the tube in between (Fig. 78).
4. Tighten the clamp screw (Fig. 79).

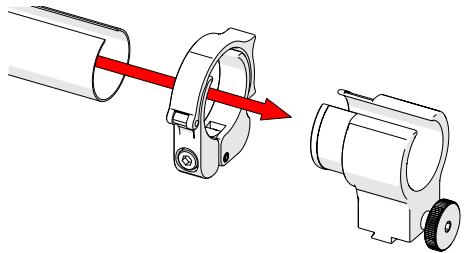

Fig. 77 - Slide tube around mount

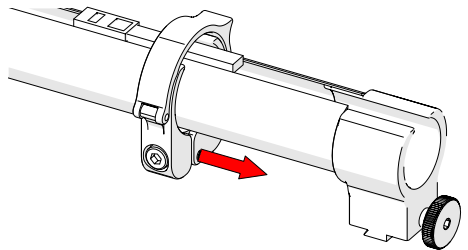

Fig. 78 - Slide clamp onto mount

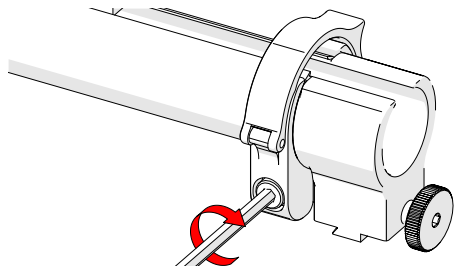

Fig. 79 - Tighten clamp screw

## 5.11. Preamp Bracket

Compatible with most standard preamps, use screws or the optional velcro straps to attach a preamp to the preamp bracket.

Intended Use

- ▶ The preamp bracket is intended to mount objects (e.g. preamps, splitters, etc.) that:
- ▶ have a maximum weight of 1.36 kg (3 lb)
- ▶ are attached to the with a lanyard or probe cables strong enough to prevent the object from falling
- ▶ have smooth edges so as not to cut the bracket's velcro strap

### 5.11.1. Mounting Preamp Bracket

The preamp bracket mounts to any dovetail groove.

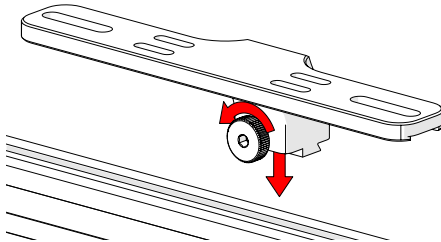

Fig. 80 - Loosen knob and mount to dovetail groove

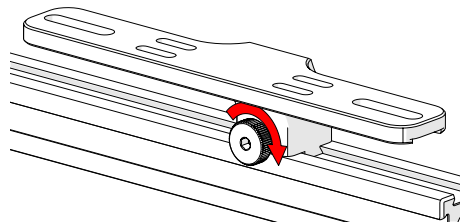

Fig. 81 - Tighten knob

1. Loosen the knob and align the dovetail nut with the dovetail groove (Fig. 80).
2. Tighten the knob to lock the preamp bracket in place (Fig. 81).

### 5.11.2. Attaching Preamp with Screws

Use the adjustable screw mounting channel on the bottom of the bracket to attach a preamp (screws not included).

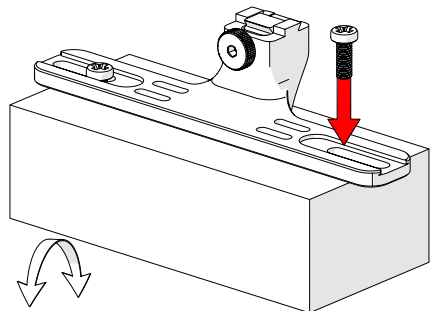

Fig. 82 - Attach preamp with screws

### 5.11.3. Attaching Preamp with Velcro Straps

To attach the preamp to the bracket using velcro straps, follow these steps:

1. Slide the velcro strap through the bracket's holes (Fig. 83).

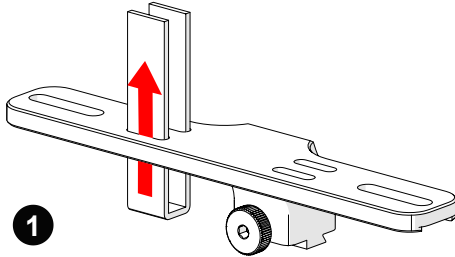

Fig. 83 - Insert velcro straps

2. Centre and place the preamp on the bracket, wrapping the velcro around the preamp (Fig. 84).
3. Secure the preamp to the bracket, attaching each side of the velcro (Fig. 85).

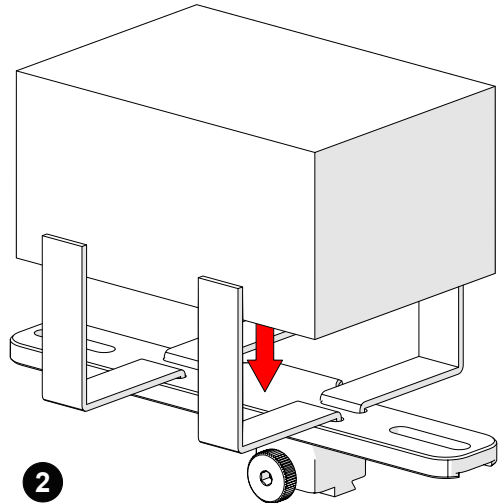

Fig. 84 - Place preamp and wrap velcro

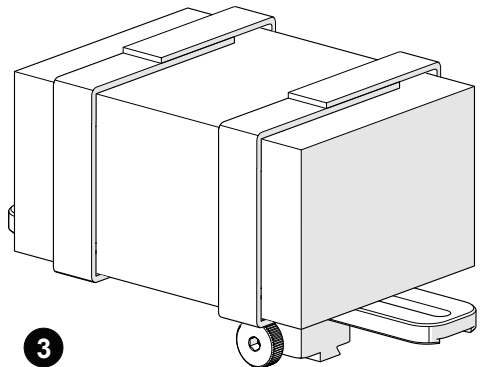

Fig. 85 - Mount bracket on a frame bar

# OPERATION

## 6.1. Setup of ROTIX on a Scanning Surface

1. Determine the diameter of the pipe or tube to be scanned. The **ROTIX** kit and this manual include a setup chart (see *Chain Configuration Setup Chart on page 49*). This chart indicates the number of links required based on the diameter of the pipe or tubing (Fig. 86).

**TIP:** The following example is a configuration for a 30.5 cm (12 in) pipe diameter.



Fig. 86 - Refer to setup chart

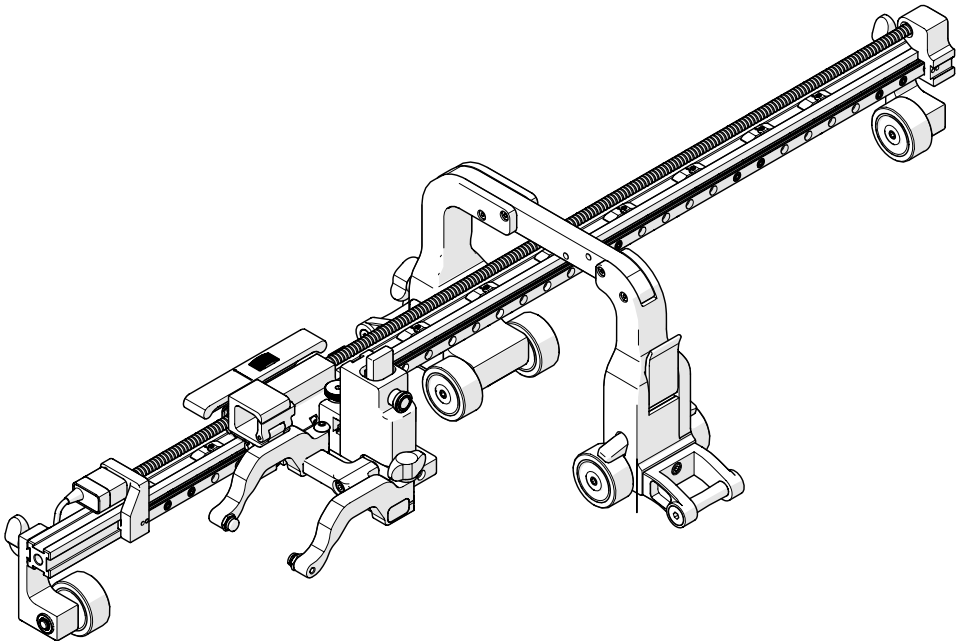

Fig. 87 - Assemble configuration

2. Ensure the appropriate configuration is set up (Fig. 87). Install the wedge to be used in the probe holder (see *Probe Holder Setup on page 21*).

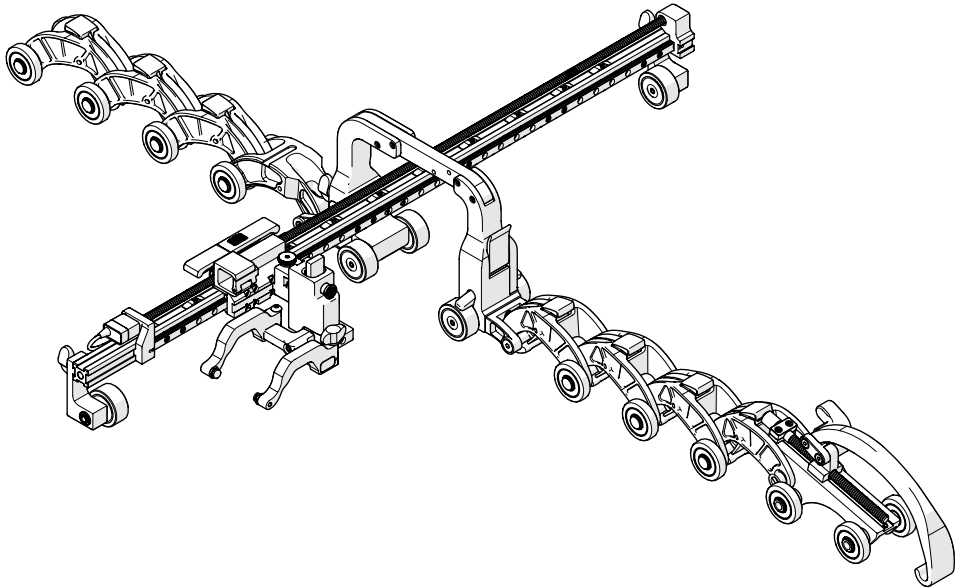

Fig. 88 - Assemble configuration

3. On a flat surface, connect the appropriate number of links (see *Connecting QuickLinks on page 19*) as indicated on the **ROTIX** setup chart. Arrange the link setup with the buckle and catch link 180° opposite the corrosion link (Fig. 88).

**TIP:** Place the dovetail link (Fig. 89-2) after the corrosion link.

4. Ensure the brake (Fig. 89-1) is activated (see *Brake on page 14*).
5. Drape the configured assembly around the pipe/tube to be inspected (Fig. 89).

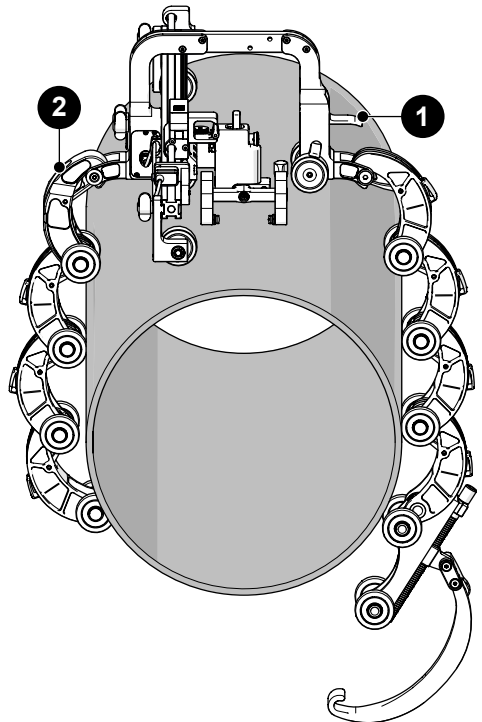

Fig. 89 - Place on pipe

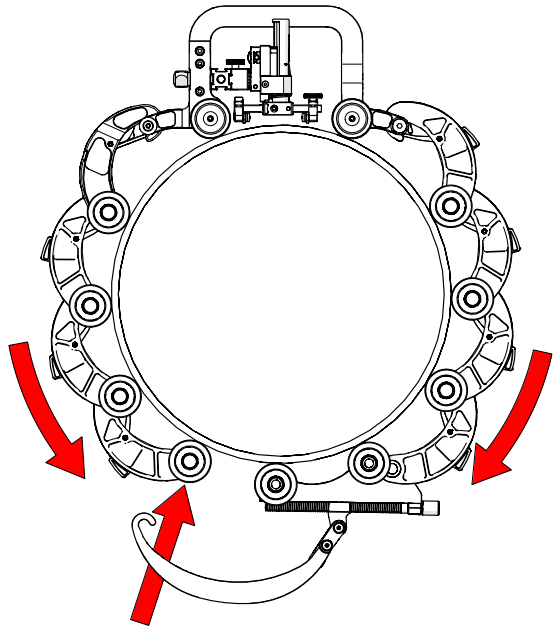

Fig. 90 - Hook QuickLink Buckle to QuickLink

6. The tightness of the **ROTIX** on the pipe can be adjusted using the QuickLink Buckle adjustment knob (Fig. 91-1).

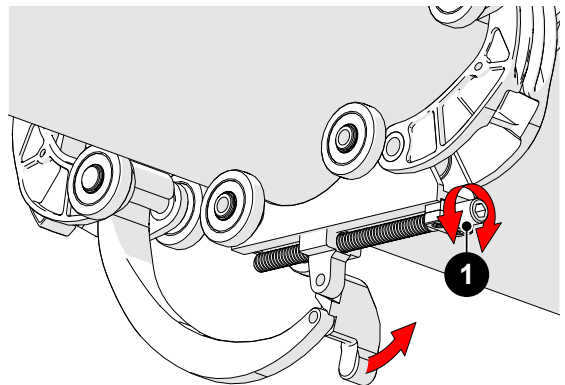

Fig. 91 - Adjust pressure of QuickLink Buckle

7. Rotate the knob until the QuickLink Buckle's lever can be pushed down, locking the QuickLink Buckle in place (Fig. 92).

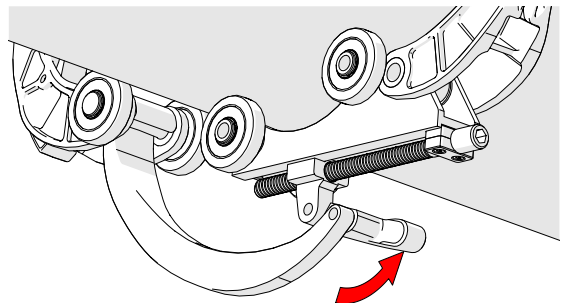

Fig. 92 - Press down to lock

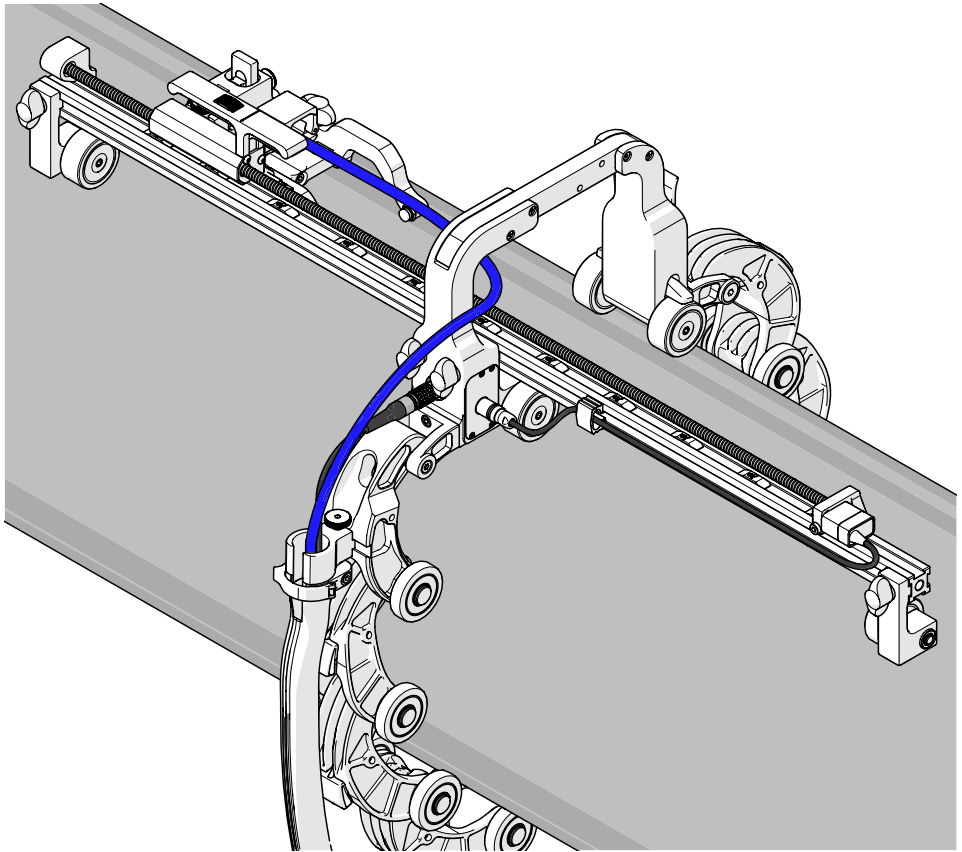

Fig. 93 - Cable and irrigation setup

8. Route all cabling and hoses (*Encoder cable and sample irrigation tube shown*) to the cable management (*see Cable Management System on page 26*).
9. Lower probe holders to the scan surface (*see Probe Holder Setup on page 21*).
10. Release the brake to commence scanning (*see Brake on page 14*).

## MAINTENANCE

General cleaning of components is important to keep your system working well. All components that have no wiring or cables are completely waterproof. Components can be washed with warm water, dish soap and a medium bristle brush.

Before using the scanner, ensure all connectors are free of water and moisture.

**NOTE:** *All components with wiring, cables or electrical connections are splashproof. However, these components are **NOT** submersible.*

**NOTE:** *Never use strong solvents or abrasive materials to clean your scanner components.*



# TROUBLESHOOTING

Problem	Possible Cause	Solution
The chain is too loose/tight.	Incorrect number of QuickLinks for proper scanner configuration.	Refer to the <b>ROTIX</b> setup chart ( <i>see Chain Configuration Setup Chart on page 49</i> ) for the required number of links for the diameter of the pipe/tube to be scanned. Ensure the correct outer diameter measurement of the pipe/tube. Reset the scanner with the correct number of links.
	The QuickLink Buckle is incorrectly set up.	Adjust the tightness of the QuickLink Buckle ( <i>see page 33</i> ).
Insufficient probe contact.	The scanner is not set correctly.	Reconfigure the scanner as per instructions ( <i>see Setup of ROTIX on a Scanning Surface on page 31</i> ).

## 8.1. Technical Support

For technical support, contact Jireh Industries (*see "Jireh Industries Ltd." on page 1*).

## SERVICE AND REPAIR



**WARNING! DO NOT DISASSEMBLE.** No user-serviceable parts. Disassembling any of the components in this product, beyond the instructions in this user manual, could void the regulatory certifications and/or effect the safety of the product.

# SPARE PARTS

To order accessories or replacement parts for your ROTIX system.  
(contact Jireh Industries Ltd. on page 1)

**NOTE:** These drawings are for parts order. This is not a list of kit contents.

## 10.1. Corrosion Scanner

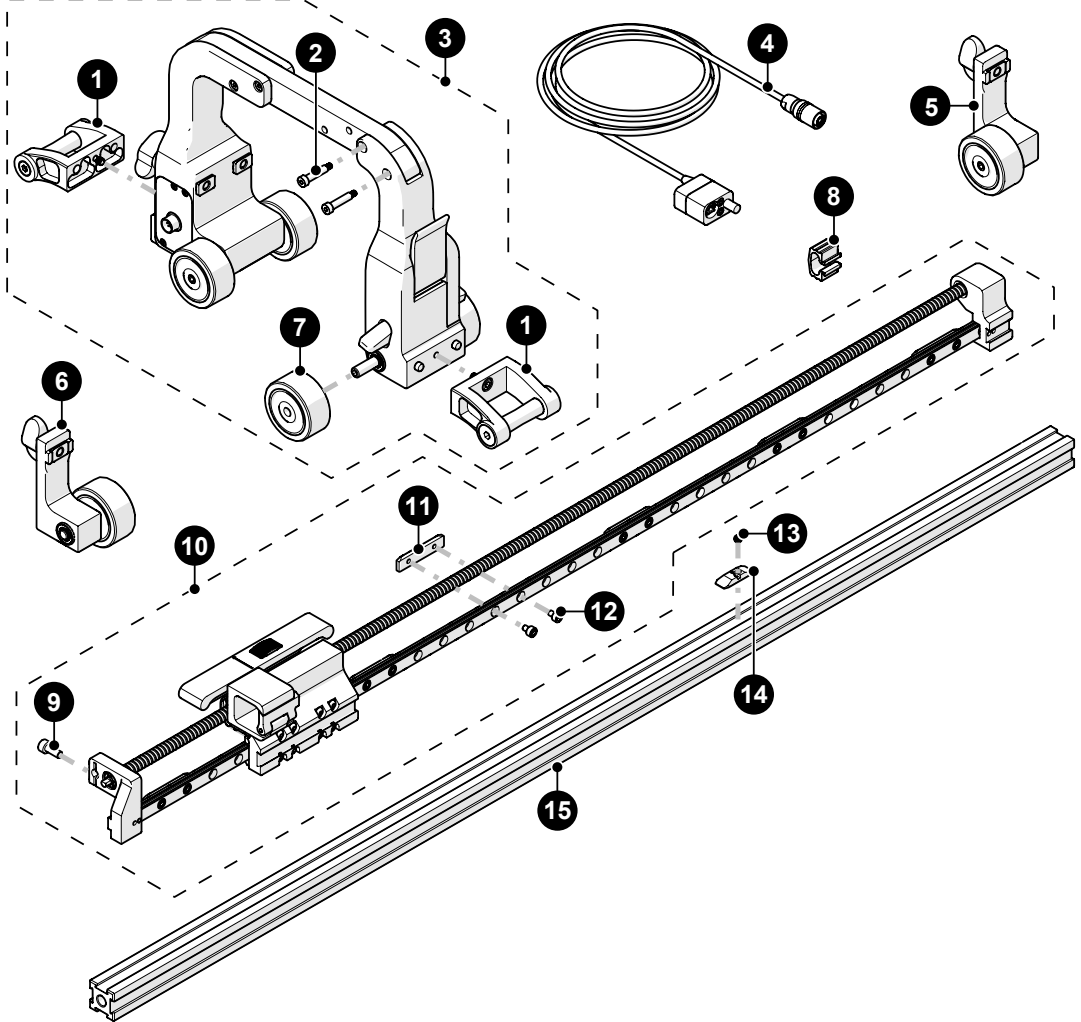

Fig. 94 - ROTIX corrosion frame parts

Part #	BOM ID	Description
1	CES095	QuickLink Tail
2	MA252	SHSB, M3 x 0.5 x 4 mm, Ø 4 mm x 16 mm, SST
3	CES097	Corrosion Link
4	DKS009-S-0.4	PPS encoder
5	CES053-L	Corrosion scanner stabilizer ( <i>left</i> )
6	CES053-R	Corrosion scanner stabilizer ( <i>right</i> )
7	CES012	Non-Magnetic wheel
8	BG0091	Cable clip
9	MD050-010	SHCS, M4x0.7 X 10 mm, SST
10	DKS010-__	Corrosion Slider
11	DK0020	Dovetail nut
12	DK0019	SHCS, M3 x 0.5 x 4.5 mm, 3 mm hex, SST
13	MA254	SHSS, M4 x 0.7 x 3 mm, flat point, SST
14	CE0116	Index nut
15	BG0090-75	Frame bar with ruler, 75 cm

## 10.2. Kit Components

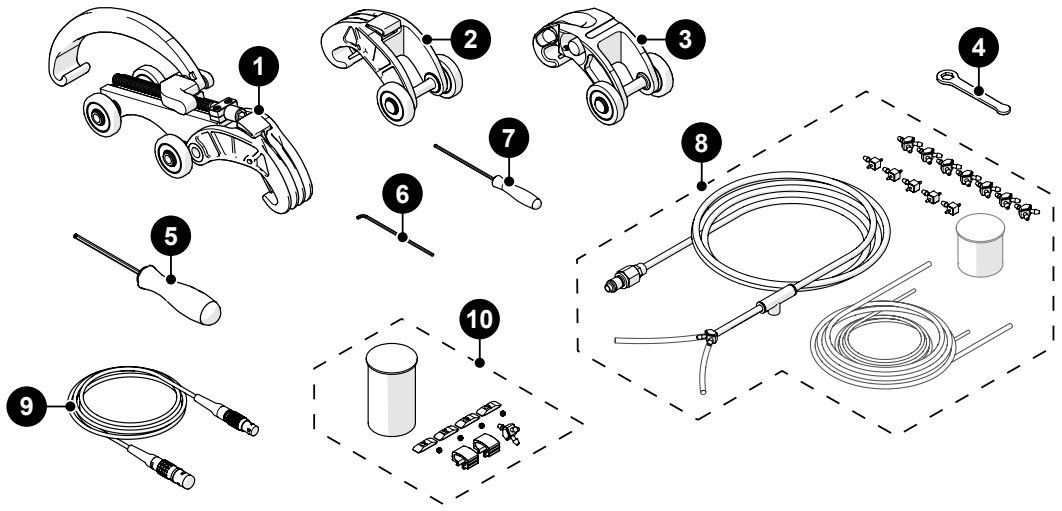

Fig. 95 - ROTIX corrosion scanner parts

Part #	BOM ID	Description
1	EES014	QuickLink Buckle
2	EES004	QuickLink
3	EES019	Dovetail QuickLink
4	EA470	10 mm (3/8 in) wrench
5	EA414	Hex driver, 3 mm (0.118 in)
6	CE0137	Short 2 mm Hex Wrench
7	EA476	Hex Driver: 2 mm (0.078 in)
8	CMG007	Irrigation kit, 2-4 probe
9	UMA026_	J100 Encoder cable (see Encoder Connector Type)
10	CEG029	Corrosion Scanner Spare Parts Kit

### 10.2.1. ROTIX Corrosion Case

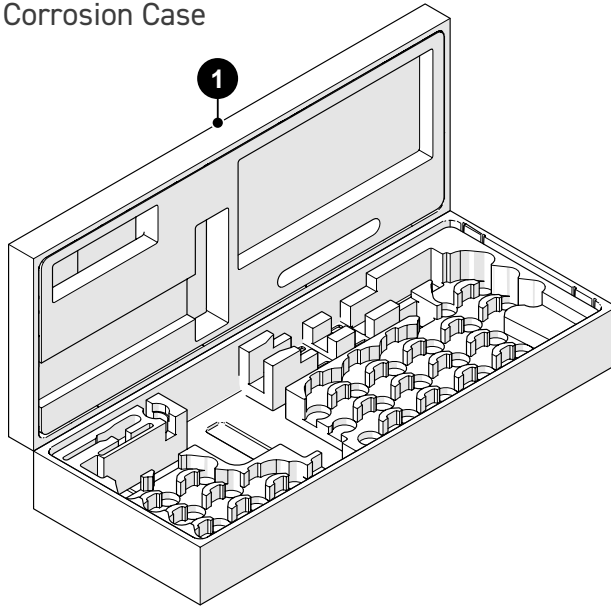

Fig. 96 - ROTIX corrosion case

Part #	BOM ID	Description
1	CEA046	ROTIX Corrosion Case

### 10.2.2. Encoder Connector Type

Connector Type	Company/Instrument	Connector Type	Company/Instrument
B	Olympus OmniScan MX Zetec Topaz	G	Sonotron Isonic 25xx
C	Olympus Focus LT Zetec Z-Scan Eddyfi Ectane 2	U	Sonatest Veo / Prisma
E	Olympus OmniScan SX/MX2/X3 M2M MANTIS/GEKKO LEMO	V	Pragma PAUT
F	TD ( <i>Technology Design</i> )	AD	Sonatest Veo / Prisma - Single Axis

**NOTE:** Additional encoder connector types are available (contact Jireh Industries Ltd. on page 1).

### 10.2.3. Cable Management, Dovetail Mount

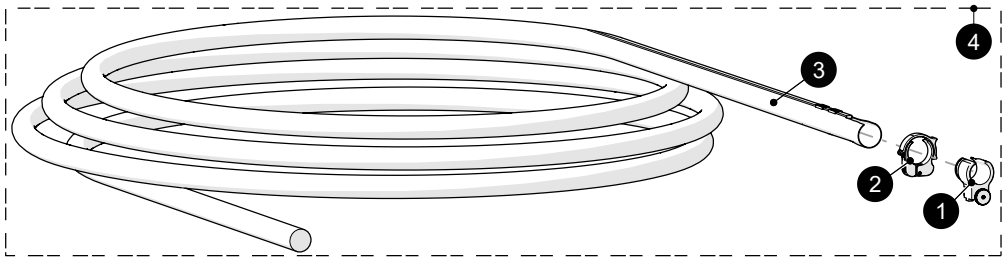

BOM ID	Part #	Description
1	CES067	Cable Management Mount, Dovetail Mount
2	CES066	Cable Management Clamp, Dovetail Mount
3	<i>See Cable Management Sleeving</i>	
4	CES044- <u>    </u>	Cable Management: Dovetail ( <i>see cable management sleeving</i> )

Fig. 97 - Cable management

#### 10.2.3.1 Cable Management Sleeving

Part #	Length
CX0141	4.5 m (14.7 ft)
CX0145	9.5 m (31.2 ft)

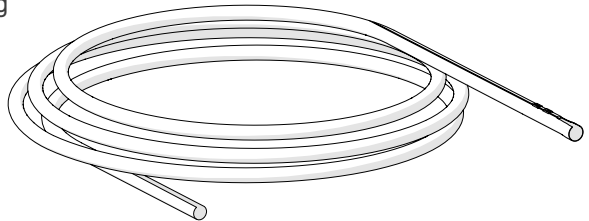

Fig. 98 - Cable management sleeving

## 10.3. Accessories

### 10.3.1. Preamp Bracket

Part #	Description
CES029	Preamp Bracket
CES029-V	Preamp Bracket with Velcro

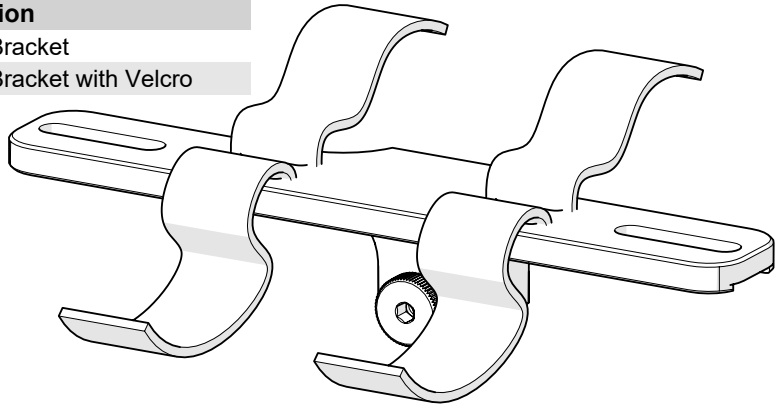

Fig. 99 - Preamp bracket

### 10.3.2. HydroFORM™ Cart

BOM ID	Part #	Description
1	PHS092	HydroFORM Cart - 2 <sup>nd</sup> Generation
2	CES054	Mini Wing Knob Assembly

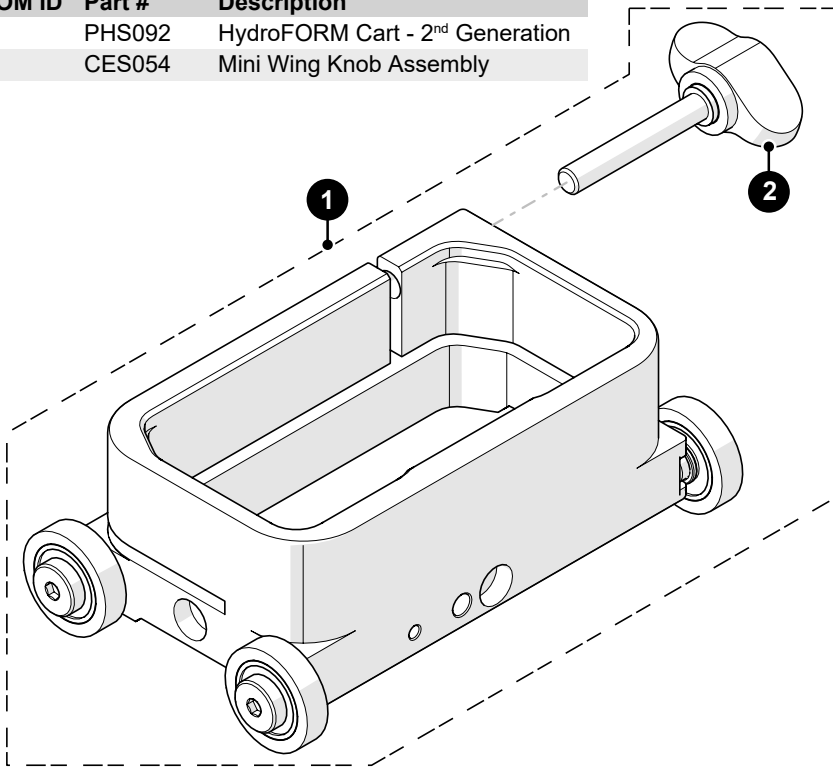
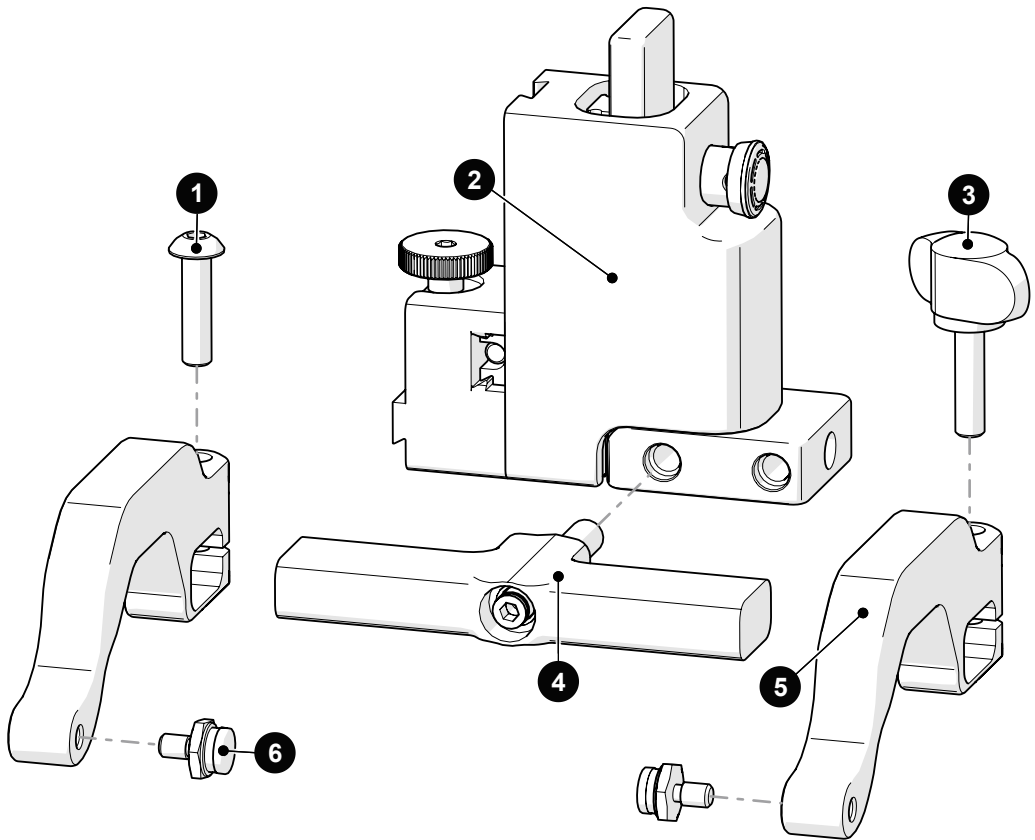

Fig. 100 - HydroFORM™ wheel replacement



## 10.4. Heavy Duty Vertical Probe Holder



BOM ID	Part #	Description
1	MD074-020	BHCS, M5 x 0.8 x 20 mm, SST
2	PHS049	Heavy Duty Probe Holder Subassembly
3	EA154	Probe Holder Arm Adjustment Knob
4	<i>See Heavy Duty Yoke Style</i>	
5	PH0165	Heavy Duty Probe Holder Arm, Standard, Drop
6	PH0011-__	Pivot Button Style ( <i>See Pivot Button Style</i> )

Fig. 101 - Heavy duty vertical probe holder

## 10.5. Probe Holder Components

### 10.5.1. Heavy Duty Yoke Style

Yoke Style	Part #	Length		Yoke Style	Part #	Length	
<b>S</b> Standard	PHS048	8.3 cm (3.26 in)		<b>W</b> Wide	PHS047	12.2 cm (4.79 in)	

Fig. 102 - Heavy duty probe holder yoke selection

### 10.5.2. Pivot Button Style









Pivot Hole Size	Wedge Type		Pivot Hole Size	Wedge Type	
<b>01</b> 8.0 mm (0.315 in)	Olympus PA		<b>02</b> 5.0 mm (0.197 in)	Olympus TOFD	
<b>03</b> 2.7 mm (0.106 in)	Sonatest DAAH PA		<b>04</b> 9.5 mm (0.375 in)	-	
<b>06</b> 3.0 mm (0.118 in)	-		<b>07</b> 2.3 mm (0.09 in)	-	
<b>08</b> Conical Head	-		<b>09</b> 5 mm (0.197 in) Internal	Zetec PA/TOFD	

Fig. 103 - Pivot button selection

**NOTE:** Additional probe holder pivot button types are available.  
(contact Jireh Industries Ltd. on page 1)

## DISPOSAL

### WEEE Directive

In accordance with European Directive on Waste Electrical and Electronic Equipment (*WEEE*), this symbol indicates that the product must not be disposed of as unsorted municipal waste, but should be collected separately. Refer to Jireh Industries for return and/or collection systems available in your country.



# LIMITED WARRANTY

## WARRANTY COVERAGE

Jireh Industries warranty obligations are limited to the terms set forth below: Jireh Industries Ltd. (“Jireh”) warrants this hardware product against defects in materials and workmanship for a period of THREE (3) YEARS from the original date of purchase. If a defect exists, at its option Jireh will (1) repair the product at no charge, using new or refurbished replacement parts, (2) exchange the product with a product that is new or which has been manufactured from new or serviceable used parts and is at least functionally equivalent to the original product, or (3) refund the purchase price of the product. A replacement product/part assumes the remaining warranty of the original product or ninety (90) days from the date of replacement or repair, whichever provides longer coverage for you. When a product or part is exchanged, any replacement item becomes your property and the replaced item becomes Jireh’s property. When a refund is given, your product becomes Jireh’s property.

## OBTAINING WARRANTY SERVICE

To utilize Jireh’s warranty service you must ship the product, at your expense, to and from Jireh Industries. Before you deliver your product for warranty service you must phone Jireh and obtain an RMA number. This number will be used to process and track your product. Jireh is not responsible for any damage incurred during transit.

## EXCLUSIONS AND LIMITATIONS

This Limited Warranty applies only to hardware products manufactured by or for Jireh Industries. This warranty does not apply: (a) to damage caused by accident, abuse, misuse, misapplication, or non-Jireh products; (b) to damage caused by service (including upgrades and expansions) performed by anyone who is not a Jireh Authorized Service Provider; (c) to a product or a part that has been modified without the written permission of Jireh.

**Jireh Industries Ltd.**

53158 Range Road 224  
Ardrossan AB T8E 2K4  
Canada

Phone: 780-922-4534

[jireh.com](http://jireh.com)

HydroFORM™ is a trademark of Olympus.

All brands are trademarks or registered trademarks of their respective owners and third-party entities.

Changes or modifications to this unit or accessories not expressly approved by the party responsible for compliance could void the user's authority to operate the equipment.

All specifications are subject to change without notice.

© 2023-2024 Jireh Industries

# APPENDIX

## 13.1. Chain Configuration Setup Chart

PIPE OD RANGE					QUICKLINKS EES004	DOVETAIL QUICKLINK EES019
MIN (in)	MAX (in)	MIN (mm)	MAX (mm)			
4.0	5.1	102	130	0	1	
5.1	6.6	130	168	1		
6.6	7.9	168	201	2		
7.9	9.2	201	234	3		
9.2	10.5	234	267	4		
10.4	11.7	264	297	5		
11.6	12.9	295	328	6		
12.8	14.0	325	356	7		
13.9	15.2	353	386	8		
15.1	16.3	384	414	9		
16.2	17.5	411	445	10		
17.3	18.6	439	472	11		
18.4	19.7	467	500	12		
19.5	20.8	495	528	13		
20.6	21.9	523	556	14		
21.7	23.0	551	584	15		
22.8	24.1	579	612	16		
23.9	25.2	607	640	17		
25.0	26.3	635	668	18		
26.1	27.4	663	696	19		
27.2	28.5	691	724	20		
28.2	29.5	716	749	21		
29.3	30.6	744	777	22		
30.4	31.7	772	805	23		
31.5	32.8	800	833	24		
32.6	33.9	828	861	25		
33.6	35.0	853	889	26		
34.7	36.0	881	914	27		
35.8	37.1	909	942	28		
36.9	38.2	937	970	29		
38.0	39.3	965	998	30		

CE0207 Rev 01



Jireh Industries Ltd.  
53158 Range Road 224  
Ardrossan, Alberta  
Canada  
T8E 2K4

780-922-4534

[jireh.com](http://jireh.com)