



**SKOOT**

DN0108 Rev 02

Automated Scanner

---

## SAFETY WARNINGS / PRECAUTIONS

### **KEEP THIS MANUAL – DO NOT LOSE**

THIS MANUAL IS PART OF THE **SKOOT** SYSTEM AND MUST BE RETAINED FOR THE LIFE OF THE PRODUCT. PASS ON TO SUBSEQUENT OWNERS.

Ensure any amendments are incorporated with this document.



**WARNING!** The **SKOOT** is designed for a specific use. Using the **SKOOT** outside of its intended use is dangerous. Failure to comply with the warnings, instructions, and specifications in this manual could result in **SEVERE INJURY** or **DEATH**. Read and understand this manual before using.



**WARNING! FALLING OBJECT HAZARD.** The area below a crawler must be kept clear at all times. A clearly marked **NO ENTRY ZONE** must be cordoned off directly below the area of crawler operation.

*(see Preparation for Safe Use on page 32 for additional details)*

**WARNING!** Do **NOT** operate or place crawler on a surface higher than 2 m (6 ft) without a proper tether held taut at all times.

*(see Tether Requirements and Attachment on page 33 for additional details)*



**WARNING! ELECTRICAL CORDS CAN BE HAZARDOUS.**

Misuse can result in **FIRE** or **DEATH** by **ELECTRICAL SHOCK**. Inspect thoroughly before each use. Do **NOT** use if damaged. Do **NOT** use when wet. Keep away from water. Do **NOT** drive, drag or place objects over cord.



**WARNING!** Do **NOT** operate scanner in an explosive environment. Do **NOT** operate scanner in the presence of volatile substances.



**WARNING! MAGNETIC MATERIAL.** The wheels of the crawler produce an extremely strong magnetic field which may cause failure or permanent damage to items such as watches, memory devices, CRT monitors, medical devices or other electronics.



Tools, magnets and metal objects can cut, pinch or entrap hands and fingers. **HANDLE WITH CARE.**

People with pacemakers or ICD's must stay at least 25 cm (10 in) away.

**WARNING! MAGNETIC MATERIAL.** The handheld controller produces a strong magnetic field which may cause failure or permanent damage to items such as watches, memory devices, CRT monitors, medical devices or other electronics.

People with pacemakers or ICD's must stay at least 10 cm (4 in) away.

**WARNING! MAGNETIC MATERIAL.** The installation/removal mat (see "Installation/Removal Mat" on page 24) contains magnetic material.

People with pacemakers or ICD's must stay at least 10 cm (4 in) away.



**WARNING! LASER RADIATION.** The battery powered optical guide contains a Class 1M laser. Do not view directly with optical instruments.



**WARNING!** If this product is to be used with any Child Products listed in (Chapter 2.3), be sure to read and comply with the warnings, instructions, and specifications in the Child Product's User Manual(s).



**WARNING! DO NOT DISASSEMBLE.** No user-serviceable parts. Disassembling any of the components in this product, beyond the instructions in this user manual, could void the regulatory certifications and/or effect the safety of the product.



**CAUTION! DO NOT** operate the **SKOOT** crawler on an inspection surface which is electrically connected to a component that is being welded.



**CAUTION!** DO NOT DISCONNECT UNDER LOAD. Shut off power before connection or disconnecting. Permanent damage to electronics could occur.



**STOP.** This symbol indicates stop button.



The WEEE symbol indicates that the product must not be disposed of as unsorted municipal waste, but should be collected separately.

*(see Disposal on page 139 for additional details).*

---

# TABLE OF CONTENTS

<b>1</b>	<b>Identification</b> .....	<b>1</b>
	1.1. Product Brand .....	1
	1.2. Manufacturer .....	1
	1.3. Compliance Declarations .....	1
	1.3.1. ISED Emissions Compliance (Canada).....	1
	1.3.2. FCC Suppliers Declaration of Conformity (United States).....	1
	1.3.3. European Union CE Declarations .....	2
	1.3.4. UKCA Declarations .....	2
<b>2</b>	<b>Product Specifications</b> .....	<b>3</b>
	2.1. Base SKOOT System Specifications .....	3
	2.1.1. Intended Use .....	3
	2.1.1.1 Operating Limits .....	4
	2.1.1.2 Operating Environment .....	5
	2.1.1.3 User .....	5
	2.1.2. Unintended Use .....	6
	2.1.3. Dimensions and Weight .....	6
	2.1.4. Power Requirements .....	8
	2.1.5. Environmental Sealing .....	8
	2.1.6. Performance Specifications .....	8
	2.1.7. Encoder Interface Specifications .....	9
	2.2. Compatible Components Specifications .....	10
	2.2.1. Low Profile Probe Holder Frame .....	10
	2.2.1.1 Intended Use .....	10
	2.2.1.2 Operating Limits .....	10
	2.2.2. Vertical Probe Holder Frame .....	10
	2.2.2.1 Intended Use .....	10
	2.2.2.2 Operating Limits .....	11
	2.2.3. Pivoting Probe Holder Frame .....	11
	2.2.3.1 Operating Limits .....	11
	2.2.4. Frame Bar .....	11
	2.2.4.1 Intended Use .....	11
	2.2.4.2 Operating Limits .....	11

2.2.5.	Preamp Bracket .....	12
2.2.5.1	Intended Use .....	12
2.2.5.2	Operating Limits .....	12
2.2.6.	Battery Powered Optical Guide .....	13
2.2.6.1	Intended Use .....	13
2.2.6.2	Operating Environment .....	13
2.2.6.3	Power Requirements .....	13
2.2.6.4	Environmental Sealing .....	13
2.2.7.	Medium Temperature Add-On Kit .....	13
2.2.7.1	Intended Use .....	13
2.2.7.2	Operating Limits .....	13
2.3.	Child Products .....	14
2.3.1.	Motorized Couplant Pump .....	14
2.3.2.	Motorized Raster Arm .....	14
2.3.3.	Optical Guide .....	14
2.3.4.	Battery Kit .....	14
2.3.5.	Preamp Kit .....	15

<b>3</b>	<b>Definitions .....</b>	<b>16</b>
3.1.	Definition of Symbols .....	16
3.2.	Definitions of Terms .....	16
3.3.	Safety Symbols .....	17
3.4.	Safety Signal Words .....	17

<b>4</b>	<b>System components .....</b>	<b>18</b>
4.1.	Base System Components .....	18
4.1.1.	SKOOT (Crawler) .....	18
4.1.1.1	Stop Button .....	18
4.1.2.	SKOOT Backpack .....	19
4.1.3.	Manipulation Handle .....	19
4.1.4.	SKOOT Umbilical .....	19
4.1.4.1	Encoder Signal Isolation .....	19
4.1.5.	Power Controller .....	20
4.1.5.1	AC/DC Power Supply .....	21
4.1.6.	Handheld Controller .....	22
4.1.7.	Auxiliary Cable .....	23
4.1.8.	J300 Encoder Cable .....	23
4.1.9.	Installation/Removal Mat .....	24
4.1.10.	Lifting Sling .....	24
4.1.11.	Irrigation Kit .....	25
4.1.12.	Cable Management .....	25

4.1.13.	Battery .....	25
4.1.14.	Charger and Power Adapter .....	26
4.1.15.	Tools .....	26
4.1.16.	Cases .....	26
4.2.	Compatible Components .....	27
4.2.1.	Low Profile Probe Holder Frame .....	27
4.2.2.	Vertical Probe Holder Frame .....	27
4.2.3.	Pivoting Probe Holder Frame .....	27
4.2.4.	Frame Bar .....	27
4.2.5.	Slip Joint Probe Holder .....	28
4.2.6.	Vertical Probe Holder .....	28
4.2.7.	Heavy Duty Vertical Probe Holder .....	28
4.2.8.	Corrosion Thickness Probe Holder .....	28
4.2.9.	HydroFORM Cart .....	28
4.2.10.	Preamp Bracket .....	29
4.2.11.	Battery Powered Optical Guide .....	29
4.2.12.	Automated Crawler Medium Temperature Add-On Kit .....	29
4.2.13.	Encoder Adapter .....	29
4.3.	Child Products .....	30
4.3.1.	Motorized Couplant Pump .....	30
4.3.2.	Motorized Raster Arm .....	30
4.3.3.	Optical Guide .....	30
4.3.4.	Battery Kit .....	30
4.3.5.	Preamp Kit .....	30
4.4.	Tools.....	31
4.4.1.	Included Tools .....	31
4.4.2.	Optional tools .....	31

**5**

**Preparation for Use .....32**

5.1.	Preparation for Transportation .....	32
5.2.	Preparation for Safe Use .....	32
5.2.1.	No Entry Fall Zone .....	32
5.2.2.	Tether Requirements and Attachment .....	33
5.2.3.	Lifting Sling Setup .....	34
5.3.	Preparation of Inspection Surface .....	34
5.4.	System Connectivity .....	35
5.5.	Configurations .....	37
5.5.1.	Crawler with Multiple Probe Holders .....	37
5.5.1.1	Vertical Probe Holder Frame .....	37
5.5.1.2	Low Profile Probe Holder Frame .....	39
5.5.1.3	Pivoting Probe Holder Frame .....	41

5.5.1.4	Flange .....	43
5.6.	Crawler .....	45
5.6.1.	Swivel Mount .....	45
5.6.2.	Umbilical .....	46
5.6.3.	Handle .....	47
5.6.4.	Stop Button .....	48
5.6.5.	Cable Retainer .....	48
5.6.6.	Manipulation Handle .....	49
5.7.	Handheld Controller .....	50
5.7.1.	Magnetic Mounts .....	50
5.8.	Backpack .....	51
5.8.1.	Mounting a Backpack .....	51
5.8.2.	Using the backpack .....	52
5.9.	Probe Holders .....	53
5.9.1.	Heavy Duty Vertical Probe Holder .....	53
5.9.1.1	Probe Holder Setup .....	53
5.9.1.2	Probe Holder Vertical Adjustment .....	55
5.9.1.3	Probe Holder Left/Right Conversion .....	56
5.9.1.4	Probe Holder 90° Adjustment .....	57
5.9.2.	Vertical Probe Holder .....	58
5.9.2.1	Probe Holder Setup .....	58
5.9.2.2	Probe Holder Vertical Adjustment .....	59
5.9.2.3	Probe Holder Transverse Adjustment .....	60
5.9.2.4	Probe Holder Longitudinal Adjustment .....	61
5.9.2.5	Probe Holder Left/Right Conversion .....	62
5.9.3.	Slip Joint Probe Holder .....	64
5.9.3.1	Probe Holder Setup .....	64
5.9.3.2	Probe Holder Adjustment .....	66
5.9.3.3	Probe Holder Force Adjustment .....	66
5.9.3.4	Slip Joint Probe Holder Left/Right Conversion .....	68
5.10.	Probe Holder Frames .....	70
5.10.1.	Low Profile Probe Holder Frame - Flat or Circumferential Only .....	70
5.10.2.	Vertical Probe Holder Frame - Flat or Circumferential Only .....	74
5.10.3.	Pivoting Probe Holder Frame .....	78
5.10.3.1	Mounting a Pivoting Probe Holder Frame .....	79
5.10.4.	Pivoting Probe Holder Frame Setup - Longitudinal Scanning .....	80
5.10.4.1	Longitudinal Scanning .....	80
5.10.4.2	Circumferential Scanning .....	81
5.10.4.3	Pivoting Probe Holder Frame - Flange Scanning .....	82
5.10.5.	Optical Guide Pivot Mount .....	85
5.11.	Accessories .....	86
5.11.1.	Battery Powered Optical Guide .....	86



5.11.2.	Cable Management .....	87
5.11.2.1	Mounting the Cable Management .....	87
5.11.2.2	Cable Management Setup .....	87
5.11.2.3	Clamp Setup .....	88
5.11.3.	Preamp Bracket .....	89
5.11.3.1	Mounting Preamp Bracket .....	89
5.11.3.2	Attaching Preamp with Screws .....	89
5.11.3.3	Attaching Preamp with Velcro Straps .....	90

## **6** Operation ..... 91

6.1.	System Startup .....	91
6.2.	Placement of Crawler on Inspection Surface .....	93
6.2.1.	Scanner Installation/Removal Mat Use.....	94
6.3.	Operation .....	96
6.3.1.	Handheld Controller Layout .....	96
6.3.1.1	Touchscreen .....	96
6.3.1.2	D-pad .....	97
6.3.1.3	Joysticks .....	97
6.3.2.	Mode Select Screen .....	97
6.3.3.	Jog Mode .....	98
6.3.4.	Latched Jog Mode .....	99
6.3.5.	1 Axis Scan Mode .....	100
6.3.5.1	1 Axis Scan Screen .....	101
6.3.6.	System Utilities Screen .....	103
6.3.6.1	User Settings Screen .....	104
6.3.6.2	Diagnostics Screens .....	105
6.3.6.2.1.	Detected Modules .....	105
6.3.6.2.2.	System 1 .....	106
6.3.6.2.3.	System 2 .....	107
6.3.6.2.4.	System 3 .....	107
6.3.6.2.5.	Skoot-L .....	108
6.3.6.3	Touch Calibration Screen .....	109
6.3.6.4	Joystick Calibration Screen .....	110
6.3.6.5	Draw .....	111
6.3.7.	High Internal Temperature Screen .....	111

## **7** Maintenance ..... 113

7.1.	Safety Precautions Before Maintenance .....	113
7.2.	Cleaning .....	113
7.3.	Maintenance Schedule .....	114

## **8** Troubleshooting ..... 115

8.1.	Startup Issues .....	115
8.1.1.	Joystick Off Centre .....	115
8.1.2.	Checking Network .....	115
8.2.	Startup Override .....	116
8.2.1.	Scan Devices .....	117
8.2.2.	Reset Parameters .....	118
8.2.3.	System Parameters .....	118
8.2.4.	Device Address.....	118
8.3.	Additional Issues .....	119
8.4.	Retrieval of a Stranded Crawler .....	120
8.5.	Technical Support .....	120

**9**

Service and Repair .....	121
--------------------------	-----

**10**

Spare Parts .....	122
-------------------	-----

10.1.	Crawler .....	122
10.2.	Kit Components .....	123
10.2.1.	Encoder Connector Type.....	125
10.2.3.	Power Cord Type .....	125
10.3.	Cable Management .....	126
10.3.2.	Cable Management Sleeving .....	126
10.4.	Probe Holder Frame .....	127
10.5.	Low Profile Probe Holder Frame .....	128
10.6.	Pivoting Probe Holder Frame .....	129
10.7.	Slip Joint Probe Holder Parts .....	130
10.8.	Vertical Probe Holder Parts .....	131
10.9.	Heavy Duty Vertical Probe Holder .....	132
10.10.	Corrosion Thickness Probe Holder .....	133
10.11.	Probe Holder Components .....	134
10.11.1.	Arm Style .....	134
10.11.2.	Yoke Style .....	134
10.11.3.	Swing Arm Style .....	134
10.11.4.	Heavy Duty Yoke Style .....	134
10.11.5.	Pivot Button Style .....	134
10.11.6.	Probe Holder Receptacle and Wear Plate .....	135
10.12.	Variable Components .....	135
10.12.1.	Frame Bar .....	135
10.13.	Accessories.....	136
10.13.1.	Automated Crawler Medium Temperature Add-On Kit .....	136

10.13.2. Preamp Bracket .....137  
10.13.3. Battery Powered Optical Guide .....137  
10.14. Cases .....138

**11** Disposal .....139

**12** Limited Warranty .....140

# IDENTIFICATION

## 1.1. Product Brand

The **SKOOT** is a remotely operated vehicle with magnetic wheels suitable for driving on ferrous material. Its primary purpose is to move inspection equipment over areas of structures, such as tanks or pipes, made from ferrous materials in industrial environments.

## 1.2. Manufacturer

Distributor:

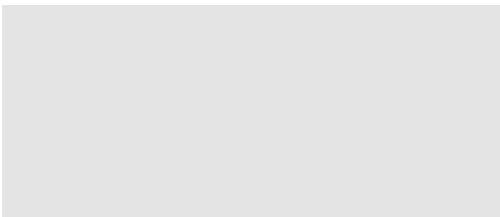

Manufacturer:

Jireh Industries Ltd.  
53158 Range Road 224  
Ardrossan, Alberta T8E 2K4  
Canada  
Phone: 780.922.4534  
jireh.com

## 1.3. Compliance Declarations

### 1.3.1. ISED Emissions Compliance (Canada)

CAN ICES-003(A) / NMB-003(A)

This Class A digital apparatus complies with Canadian ICES-003.

*Cet appareil numérique de la classe A est conforme à la norme NMB-003 du Canada.*

### 1.3.2. FCC Suppliers Declaration of Conformity (United States)

This device complies with Part 15 of the FCC Rules. Operation is subject to the following two conditions: (1) this device may not cause harmful interference, and (2) this device must accept any interference received, including interference that may cause undesired operation.

This equipment has been tested and found to comply with the limits for a Class A digital device, pursuant to part 15 of the FCC Rules. These limits are designed to provide reasonable protection against harmful interference when the equipment is operated in a commercial environment. This equipment generates, uses, and can radiate radio frequency energy and, if not installed and used in accordance with the instruction manual, may cause harmful interference to radio communications. Operation of this equipment in a residential area is likely to cause harmful interference in which case the user will be required to correct the interference at his own expense.

<b>RESPONSIBLE PARTY NAME:</b>	Jireh Industries
<b>ADDRESS:</b>	2955 S Sam Houston Pkwy E Suite 300 Houston, Texas United States 77047
<b>TELEPHONE:</b>	832-564-0626

**1.3.3. European Union CE Declarations**

Jireh Industries hereby declares that the SKOOT product complies with the essential requirements and other relevant provisions of the following European Union directives:



- 2014/30/EU      EMC Directive
- 2014/35/EU      Low Voltage Directive
- 2012/19/EU      Directive on Waste Electrical and Electronic Equipment
- 2011/65/EU      Directive on Restriction of Hazardous Substances (RoHS)

**1.3.4. UKCA Declarations**

Jireh Industries hereby declares that the SKOOT product complies with the essential requirements and other relevant provisions of the following UK directives.



Title	Edition/Date of Issue
Electromagnetic Compatibility Regulations	2016
Electrical Equipment (Safety) Regulations	2016
Waste Electrical and Electronic Equipment Regulations	2013
Restriction of the Use of Certain Hazardous Substances in Electrical and Electronic Equipment Regulations	2012

## PRODUCT SPECIFICATIONS

### 2.1. Base SKOOT System Specifications

This section outlines the product specifications of the base system. When the base system is used together with compatible components (*Chapter 2.2*) or child products (*Chapter 2.3*), the product specifications of the base system may be superseded. See (*see “Compatible Components Specifications” on page 10*) and (*see “Child Products” on page 14*)

#### 2.1.1. Intended Use



#### **WARNING! FALLING OBJECT HAZARD.**

The **SKOOT** is intended for a specific use. Read and understand the intended and unintended use limits below. Using the **SKOOT** outside of its intended use is dangerous and could result in **SEVERE INJURY** or **DEATH**.

The **SKOOT**'s primary purpose is to perform inspections of ferrous assets such as pipes, vessels, or storage tanks by moving an inspection tool over a ferrous surface. It is intended for industrial use only.

### 2.1.1.1 Operating Limits

Category	Parameter	Specification
Inspection Surface	Maximum coating thickness:	
	Up-side-down orientation	Bare metal only
	Vertical orientation	0.5 mm (0.020 in)
	Horizontal, Right-side-up orientation	1 mm (0.040 in)
	Condition	Clean, free of excess rust, scale, debris (i.e. dirt, sand, etc.), ice, frost
	Minimum thickness	3 mm (0.120 in)
	Minimum ID, internal circumferential driving	686 mm (27 in)
	Minimum ID, internal longitudinal driving	Flat ( <i>Internal longitudinal driving not recommended</i> )
	Minimum OD, external circumferential driving	64 mm (2.5 in)
	Minimum OD, external longitudinal driving	762 mm (30 in)
Maximum surface temperature	50°C (122°F)	

Category	Parameter	Specification
Scanner	Maximum umbilical length	30 m (100 ft)
	Maximum payload <i>(performance may vary with surface condition)</i>	9 kg (20 lb) <i>(Umbilical and attachments are considered payload)</i>
	Attachments	Restricted to those listed in compatible components or child products
	Orientation while driving at height >2 m (6 ft) on vertical surface	Umbilical strain relief to point downwards, or at worst, horizontal. It is not to point upwards
	Required radial clearance <i>(stick handle and backpack removed, front handle lowered, circumferential driving)</i>	102 mm (4 in) on outer diameters <200 mm (8 in) 112 mm (4.4 in) on outer diameters >200 mm (8 in)
Backpack	Maximum weight of mounted object	1.36 kg (3 lb)
	Condition of mounted object	Attached to crawler with lanyard or cables strong enough to prevent object from falling  Smooth edges to prevent cutting of strap

### 2.1.1.2 Operating Environment

The SKOOT is for use in dry industrial environments having ambient temperatures shown below. It is **NOT** intended for use in explosive environments.

Category	Parameter	Specification
Environment	Minimum ambient temperature	-20°C (-4°F)
	Maximum ambient temperature	50°C (122°F)

### 2.1.1.3 User

The SKOOT is intended to be used by persons who have read and understand the user manual. The intended user is to be a person without limitations in the physical abilities of the upper and lower limbs, sight, hearing, or anyone with a pacemaker or Implantable Cardioverter Defibrillator (ICD).

For operating at a height greater than 2 m (6 ft), the SKOOT is intended to be used by two people:



1. a person who is trained in rigging and fall protection and is able to effectively apply the same safety principles to the crawler, and
2. a person who is trained to operate the SKOOT

### 2.1.2. Unintended Use

The SKOOT is NOT intended for:

- ▶ use outside of its intended use
- ▶ unattended use
- ▶ lifting / lowering objects or people (*i.e. using the SKOOT as a crane / elevator*)
- ▶ driving into / over obstructions, excluding standard weld caps
- ▶ installation on a surface on which welding is actively occurring

In addition to the above points, for operating at a height greater than 2 m (6 ft), the crawler is NOT intended for:

- ▶ operation without a properly cordoned off no entry fall zone and/or proper tether system
- ▶ operating up-side-down
- ▶ operating while oriented such that the umbilical strain relief points upward (*front for the SKOOT is lower than the umbilical connection*).

### 2.1.3. Dimensions and Weight

Crawler height:	14.9 cm	5.9 in
Crawler width:	20.8 cm	8.2 in
Crawler depth:	21.8 cm	8.6 in
Crawler height ( <i>handle down</i> ):	11.2 cm	4.4 in
Crawler weight: *	7.3 kg	16 lb

\* Configuration excluding case, attachments, umbilical, manipulation handle, power controller and handheld controller.

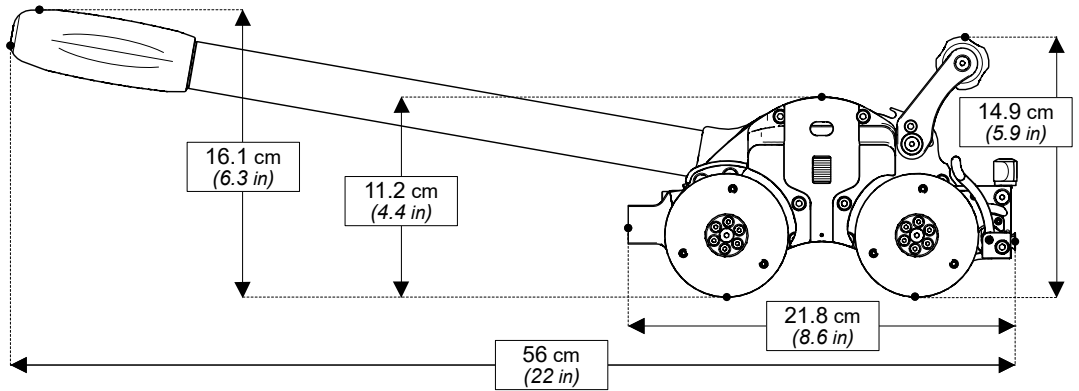

Fig. 1 - Crawler dimensions

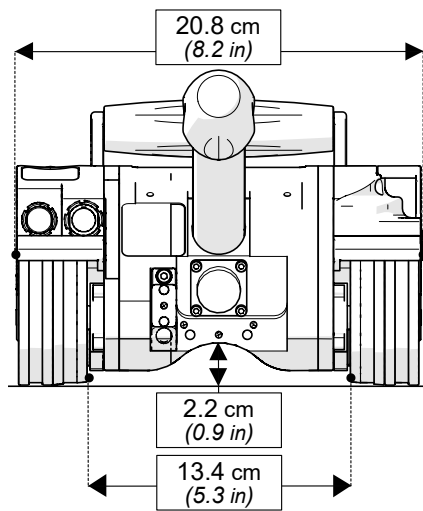

Fig. 2 - Width

## 2.1.4. Power Requirements



**WARNING!** A reliable power source must be used to power the crawler. Connections must be secured to prevent accidental disconnection. Power failure may cause the crawler to freewheel down when operating in a vertical orientation. Portable generator usage is not recommended unless accompanied by the use of an uninterruptible power controller.



**WARNING!** Proper grounding of the power controller is important for safe operation. When a generator is used to supply power to the system (*not recommended*), the generator must be properly grounded (*refer to generator manual*).



**CAUTION! DO NOT DISCONNECT UNDER LOAD.** Shut off power before connection or disconnecting. Permanent damage to electronics could occur.



**CAUTION!** Power must be supplied from an approved Jireh power source.

Input Voltage: 25-45VDC

Input Power: 320 W

## 2.1.5. Environmental Sealing

Dust-tight, watertight (*not submersible*).

## 2.1.6. Performance Specifications

Category	Parameter	Specification
Crawler	Maximum speed	14.2 cm/sec (5.6 in/sec)
	Encoder resolution, drive motor	1354 counts/mm (34394 counts/in)

### 2.1.7. Encoder Interface Specifications

Output type: 4 channel quadrature 5VDC RS422 compatible.

Power: Power must be supplied to the interface.

5VDC +/-10% power limited to < 15w.

1	Enc B
2	Enc B'
3	Enc A
4	Enc A'
5	Aux Enc A'
6	Aux Enc A
7	Aux Enc B'
8	Aux Enc B
9	Enc +5V
10	Enc Com
H	Shield

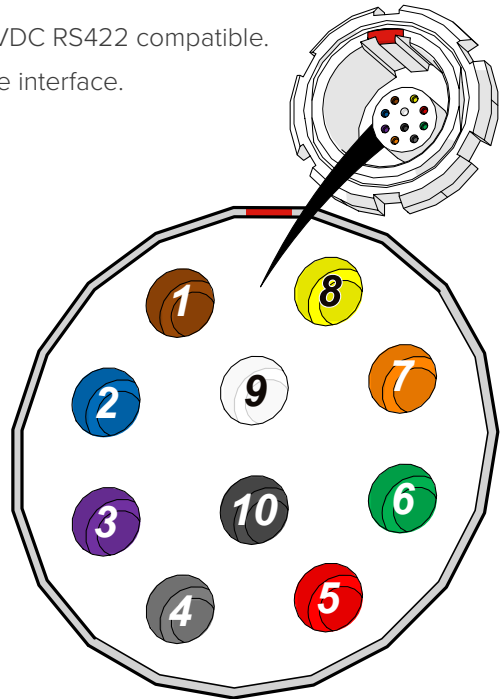

Fig. 3 - Jireh Industries pin out configuration

## 2.2. Compatible Components Specifications

The components listed in this section integrate with the base system to perform certain tasks. Their use may modify the product specifications (*i.e. intended use, power requirements, etc.*) from those of the base system. The specifications listed here supersede those of the base system. If no specifications are listed here, the specifications of the base system remain effective.

### 2.2.1. Low Profile Probe Holder Frame CXG004-

#### 2.2.1.1 Intended Use

The Low Profile Probe Holder Frame is intended to be mounted in the SKOOT's swivel mount to provide mounting of multiple probe holders. Its use limits the SKOOT's operation to inspection surfaces that are either flat or driven on in the circumferential direction.

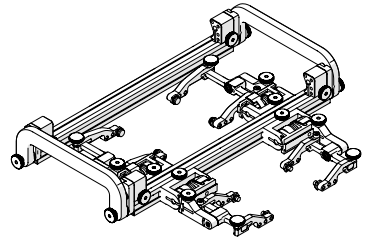

Fig. 4 - Low profile probe holder frame

#### 2.2.1.2 Operating Limits

Category	Parameter	Specification
Inspection Surface	Minimum OD, longitudinal driving	Not recommended
Maximum number of probe holders	Slip joint probe holders	4

### 2.2.2. Vertical Probe Holder Frame CXG007-

#### 2.2.2.1 Intended Use

The Vertical Probe Holder Frame is intended to be mounted in the SKOOT's swivel mount to provide mounting of multiple probe holders. Its use limits the SKOOT's operation to inspection surfaces that are either flat or driven on in the circumferential direction.

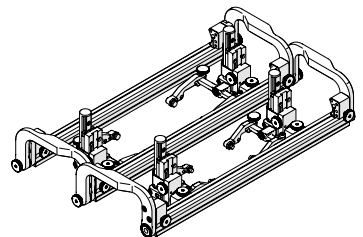

Fig. 5 - Vertical probe holder frame

### 2.2.2.2 Operating Limits

Category	Parameter	Specification
Inspection Surface	Minimum OD, longitudinal driving	Not recommended
Maximum number of probe holders	Vertical probe holders	6

### 2.2.3. Pivoting Probe Holder Frame CXG013-

The Pivoting Probe Holder Frame is intended to be mounted in the SKOOT's swivel mount to provide mounting of multiple probe holders. Its use limits the SKOOT's operation to the operating limits shown below.

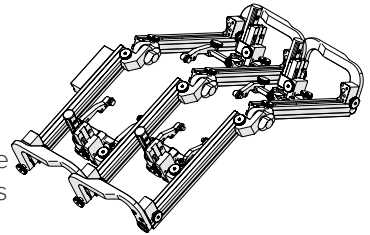

Fig. 6 - Pivoting probe holder frame

#### 2.2.3.1 Operating Limits

Category	Parameter	Specification
Maximum number of probe holders	Vertical probe holders	6

### 2.2.4. Frame Bar BG0038-

#### 2.2.4.1 Intended Use

The Frame Bar is intended to be mounted in the SKOOT's swivel mount to provide mounting of multiple probe holders. Its use limits the SKOOT's operation to inspection surfaces that are either flat or driven on in the circumferential direction.

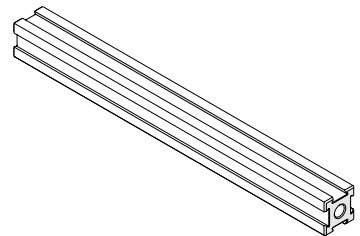

Fig. 7 - Frame bar

#### 2.2.4.2 Operating Limits

Category	Parameter	Specification
Inspection Surface	Minimum OD, longitudinal driving	Not recommended

Maximum number of probe holders	Slip joint probe holders	2
	Vertical probe holders	2
	Heavy duty vertical probe holders	2

## 2.2.5. Preamp Bracket CES029-

### 2.2.5.1 Intended Use

The Preamp Bracket is intended to mount objects such as preamps, splitters, etc. on a rack or dovetail bar that is mounted to the SKOOT crawler. The mounted object is attached to the SKOOT with a lanyard or probe cables strong enough to prevent the object from falling, should the straps or screws that hold it to the bracket fail. Also, if the object is mounted with straps, it is to have smooth edges so as not to cut the straps.

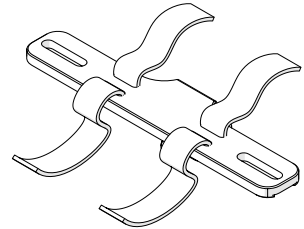

Fig. 8 - Preamp bracket

### 2.2.5.2 Operating Limits

Category	Parameter	Specification
Preamp Bracket	Maximum weight of mounted object	1.36 kg (3 lb)
Scanner	Required radial clearance ( <i>handles removed circumferential driving</i> )	Dependent on object mounted on Preamp Bracket.

## 2.2.6. Battery Powered Optical Guide CXS080

### 2.2.6.1 Intended Use

The Battery Powered Optical Guide is intended to provide a point of reference useful for guiding the SKOOT along a given path (*i.e. a weld cap*). It is intended to be mounted in the dovetail groove of any probe holder frame or frame bar.

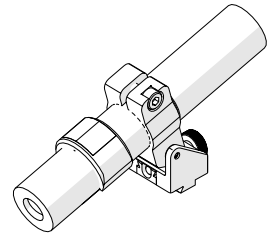

Fig. 9 - Battery powered optical guide

### 2.2.6.2 Operating Environment

Category	Parameter	Specification
Scanner	Required radial clearance	Dependent on mounted orientation of Optical Guide.

### 2.2.6.3 Power Requirements

Power requirements: 1 AA battery

### 2.2.6.4 Environmental Sealing

IP64

## 2.2.7. Medium Temperature Add-On Kit CXG031-

### 2.2.7.1 Intended Use

The Medium Temperature Add-On Kit allows the SKOOT to operate on hotter inspection surfaces.

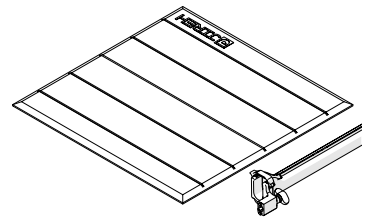

Fig. 10 - Automated crawler medium temperature add-on kit

### 2.2.7.2 Operating Limits

Category	Parameter	Specification
Inspection surface	Maximum surface temperature	150°C (302°F)



## 2.3. Child Products

The products listed in this section integrate with the base system to perform certain tasks. Their use may modify the product specifications (*i.e. intended use, power requirements, etc.*) from those of the base system. These products have a user manual of their own, and shall be referred to for their product specifications as well as how their use modifies the product specifications of the base system.

### 2.3.1. Motorized Couplant Pump CMA015

The Motorized Couplant Pump is a powered pumping unit that supplies couplant fluid to scanning equipment.

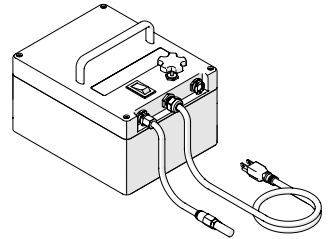

Fig. 11 - Motorized couplant pump

### 2.3.2. Motorized Raster Arm CWG002-

Available in various lengths, the Motorized Raster Arm can carry many different probes for various types of corrosion scans. The Motorized Raster Arm is intended to be mounted in the SKOOT's swivel mount.

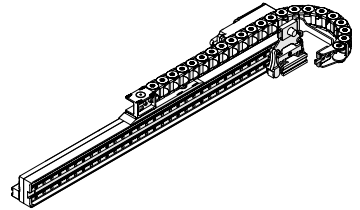

Fig. 12 - Motorized raster arm

### 2.3.3. Optical Guide CXG035

The Optical Guide mounts to any dovetail attached to a motorized crawler. The Optical Guide provides a green colour, point of reference for guiding scanners along a given path (*i.e. a weld*).

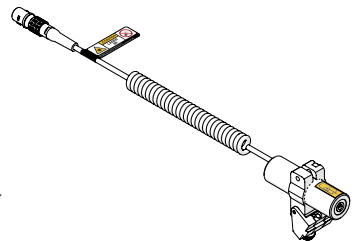

Fig. 13 - Optical guide

### 2.3.4. Battery Kit DVG001-

The battery provides portable power to the crawler.

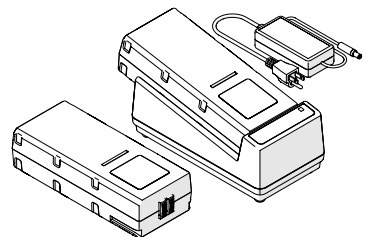

Fig. 14 - Battery

### 2.3.5. Preamp Kit CXG040-

The Preamp amplifies the return signal from an ultrasonic transducer to improve the signal-to-noise ratio for transmission over long cables.

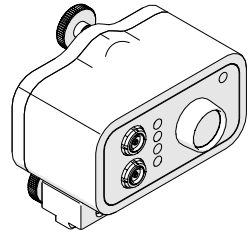

Fig. 15 - Preamp kit

# DEFINITIONS

## 3.1. Definition of Symbols



Instructions to 'look here' or to 'see this part'.

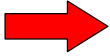

Denotes movement. Instructing user to carry out an action in a specified direction.

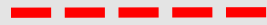

Indicates alignment axis.



Alerts the user that the view has changed to a reverse angle.

## 3.2. Definitions of Terms

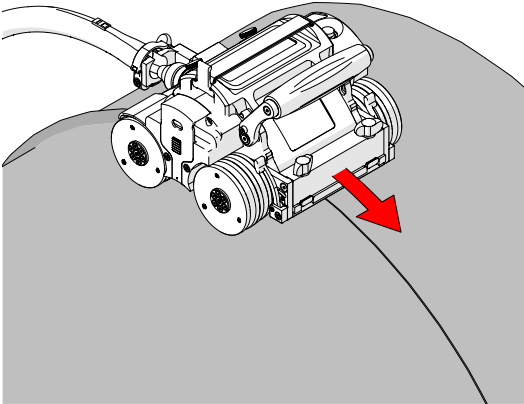

Fig. 16 - Circumferential scanning

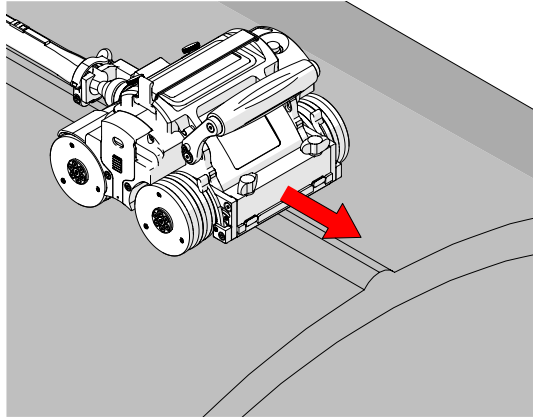

Fig. 17 - Longitudinal scanning

Circumferential



Direction of scan travel is around the circumference of the pipe/tube (Fig. 16).

Longitudinal

Direction of scan travel is lengthwise of the pipe/tube (Fig. 17).

### 3.3. Safety Symbols

The following safety symbols might appear on the product and in this document. Read and understand their meaning below:

	General warning symbol	This symbol is used to alert the user to potential hazards. All safety messages that follow this symbol shall be obeyed to avoid possible harm or material damage.
	Shock hazard caution symbol	This symbol is used to alert the user to potential electric shock hazards. All safety messages that follow this symbol shall be obeyed to avoid possible harm.
	Laser warning symbol	This symbol is used to alert the user to potential laser hazards. All safety messages that follow this symbol shall be obeyed to avoid possible harm or material damage.

### 3.4. Safety Signal Words

The following safety signal words might appear in this document. Read and understand their meaning below:

**DANGER!**

The DANGER signal word indicates an imminently hazardous situation. It calls attention to a procedure, practice, or the like that if not correctly performed or adhered to will result in death or serious personal injury. Do not proceed beyond a DANGER signal word until the indicated conditions are fully understood and met.

**WARNING!**

The WARNING signal word indicates a potentially hazardous situation. It calls attention to a procedure, practice, or the like that if not correctly performed or adhered to could result in death or serious personal injury. Do not proceed beyond a WARNING signal word until the indicated conditions are fully understood and met.

**CAUTION!**

The CAUTION signal word indicates a potentially hazardous situation. It calls attention to a procedure, practice, or the like that if not correctly performed or adhered to may result in minor or moderate personal injury, material damage, particularly to the product, destruction of part or all of the product, or loss of data. Do not proceed beyond a CAUTION signal word until the indicated conditions are fully understood and met.

## SYSTEM COMPONENTS

### 4.1. Base System Components

#### 4.1.1. SKOOT (Crawler) DNA004



**WARNING! MAGNETIC MATERIAL.** The wheels of the crawler produce an extremely strong magnetic field which may cause failure or permanent damage to items such as watches, memory devices, CRT monitors, medical devices or other electronics. People with pacemakers or ICD's must stay at least 25 cm (10 in) away.

The SKOOT Crawler (Fig. 18) is a modular, motorized, scanner that can carry various attachments for scanning and inspection applications.

The crawler includes the motor encoder, umbilical connections and accessory mounting point.

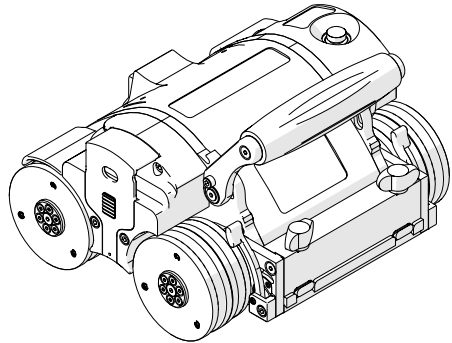

Fig. 18 - SKOOT (crawler)

##### 4.1.1.1 Stop Button

The red button on the top left of the crawler provides a stop button to the entire system. When pressed, all power to the **SKOOT** system will disengage.

**NOTE:** Terminating system power may cause the crawler to freewheel down when operating in a vertical orientation.

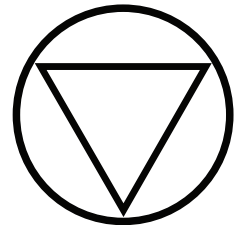

Fig. 19 - Stop

#### 4.1.2. SKOOT Backpack DNS008

The SKOOT Backpack provides a mounting point for scanning peripherals (Fig. 20).

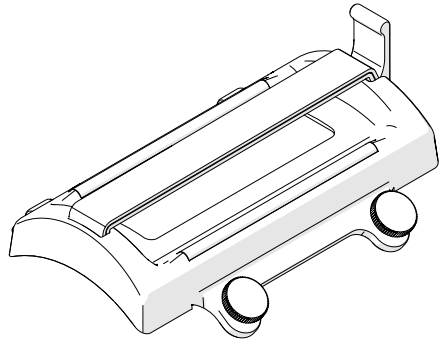

Fig. 20 - SKOOT Backpack

#### 4.1.3. Manipulation Handle DNS006

The manipulation handle allows for adjusting the scanner direction (Fig. 21).

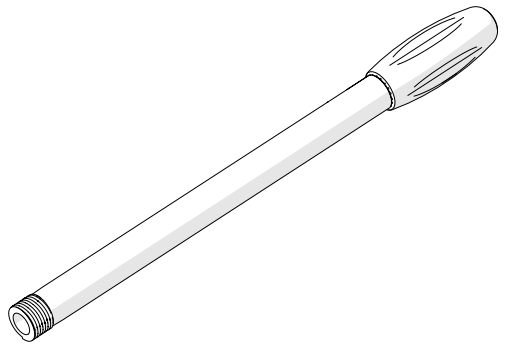

Fig. 21 - Manipulation handle

#### 4.1.4. SKOOT Umbilical UMA022-

The SKOOT relies on the umbilical to provide all the necessary power, network distribution, and encoder signals. The SKOOT Umbilical is specifically designed to connect the Crawler to the Power Controller, enabling uninterrupted power and data transmission during inspections (Fig. 22).

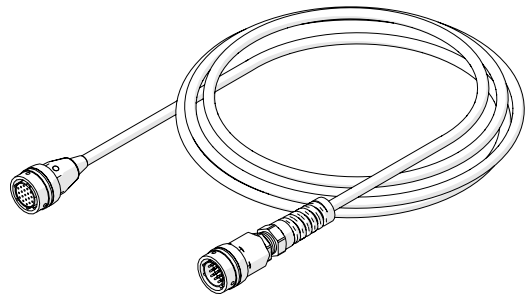

Fig. 22 - SKOOT Umbilical

##### 4.1.4.1 Encoder Signal Isolation

The umbilical contains a built-in circuit which buffers encoder signals in addition to providing isolation and protection to user instrumentation. The isolator requires 5VDC from the user's instrument and this is built into the supplied encoder cables.

#### 4.1.5. Power Controller CXA040-



**CAUTION!** DO NOT DISCONNECT UNDER LOAD. Shut off power before connection or disconnecting. Permanent damage to electronics could occur.



**WARNING!** There are no user serviceable components inside the power controller. Dangerous voltages can be present inside the case. Do **NOT** open. Return to manufacturer for repair.

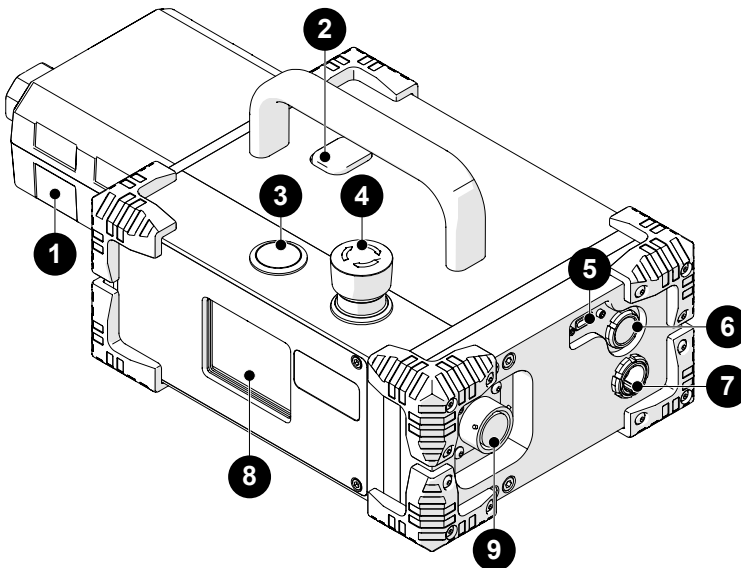

Fig. 23 - Power controller

The power controller (*Fig. 23*) accepts 25-45VDC power from the AC/DC power supply or battery. A start/stop safety circuit, and physical **ON** and **OFF** push-buttons are integrated into the power controller.

- |                                    |   |
|------------------------------------|---|
| <p><b>1</b> AC/DC power supply</p> | <p>Connect the plug from a properly grounded source.<br/>Use IEC320 cord approved for AC/DC power supply.</p> |
|------------------------------------|---|

2	Release button	Unlatch the AC/DC power supply or battery from the power controller.
3	Power button	Activate system power by pressing <i>(and releasing)</i> the silver button.
4	Stop button	The red stop button latches down when pressed. This stop button shuts down the system. Twist the stop button clockwise to return to the released position. This must be done before power can be activated.
5	Scanlink™ connector	Connection for Scanlink devices.
6	CTRL socket	Connection for the auxiliary cable.
7	ENC socket	Connection for the encoder cable.
8	Status LCD	Power controller status display.
9	Umbilical connection	Connection for the umbilical.

In the event of a break in the stop circuit (*the stop circuit runs through the power controller cable, umbilical and the crawler's stop button*), the power will shut off.

#### 4.1.5.1 AC/DC Power Supply



**WARNING! ELECTRICAL CORDS CAN BE HAZARDOUS.** Misuse can result in **FIRE** or **DEATH** by **ELECTRICAL SHOCK**. Inspect thoroughly before each use. Do **NOT** use if damaged. Do **NOT** use when wet. Keep away from water. Do **NOT** drive, drag or place objects over cord.

The 1 AC/DC power supply (Fig. 23) is used to connect the power controller to a suitable 100-240VAC, 50/60Hz grounded power source capable of supplying a minimum of 5 amps.

The power controller's safety relies on providing a proper ground connection.

In environments with moisture present, a GFCI (*Ground Fault Circuit Interrupter*) must be used to ensure operator safety.

**NOTE:** Some generators or DC-AC inverters may introduce significant levels of noise to the system. This may degrade overall system performance or reduce the system life expectancy. Using generators or DC-AC inverters is not recommended and is used at the operator's risk.



#### 4.1.6. Handheld Controller DMA006



**WARNING! MAGNETIC MATERIAL.** The handheld controller contains magnetic material. Those with pacemakers or ICD's must stay at least 10 cm (4 in) away.



**CAUTION! DO NOT DISCONNECT UNDER LOAD.** Shut off power before connection or disconnecting. Permanent damage to electronics could occur.



The handheld controller (Fig. 24) is used to manipulate a scanner installed on an inspection surface. User settings and scan information are edited using the handheld controller. The handheld controller is connected to the power controller with the auxiliary cable.

The handheld controller utilizes a resistive touch screen. Care should be taken not to use sharp or gritty objects on the screen as the touch membrane can scratch. If the screen is damaged, all programmed functions can still be accessed using the D-pad.

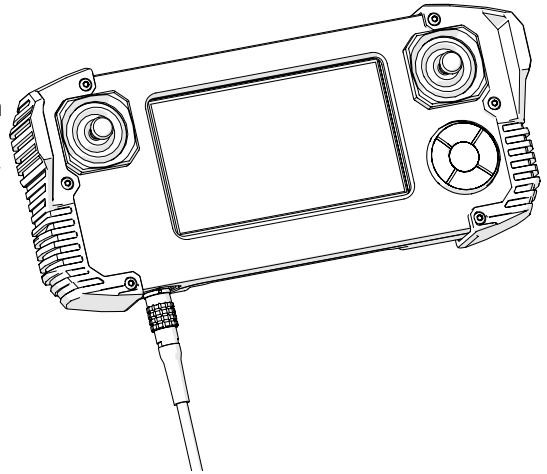

Fig. 24 - Handheld controller

**NOTE:** Do **NOT** connect the handheld controller while the system is activated.

#### 4.1.7. Auxiliary Cable UMA017-

The auxiliary cable (*Fig. 25*) connects the handheld controller to the power controller. 36VDC and network signals are used in the cable.

Both auxiliary cable connectors are identical and interchangeable. The cable may be plugged into the 4-pin receptacle on the power controller or the crawler's umbilical.

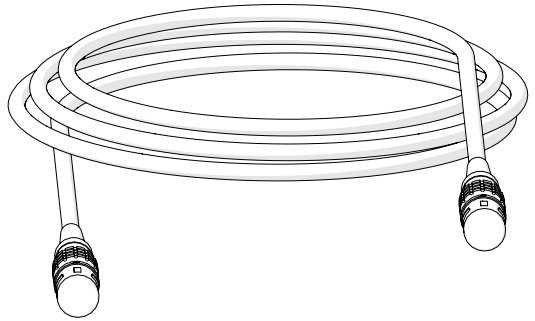

Fig. 25 - Auxiliary cable

#### 4.1.8. J300 Encoder Cable UMA025-

The encoder cable (*Fig. 26*) connects the **SKOOT** system to the user's instrument. This cable allows the transmission of two-axis position signals from the **SKOOT** to the instrument. The encoder cable also provides 5VDC from the user's instrument to the encoder isolation circuitry.

Various encoder styles are available for various instruments.

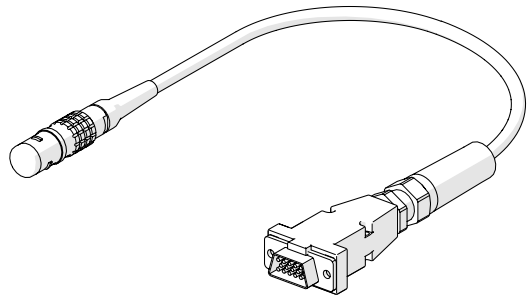

Fig. 26 - Encoder cable

#### 4.1.9. Installation/Removal Mat AAS061

 **WARNING! MAGNETIC MATERIAL.** The installation/removal mat contains magnetic material. Those with pacemakers or ICD's must stay at least 10 cm (4 in) away.



The installation/removal mat (Fig. 27) is used to install and remove motorized magnetic-wheeled scanners from the inspection surface. A motorized scanner can drive on/off the mat while the integrated magnets in the mat hold it firmly in place on the inspection surface. The scanner installation mat can be used on both round and flat surfaces.

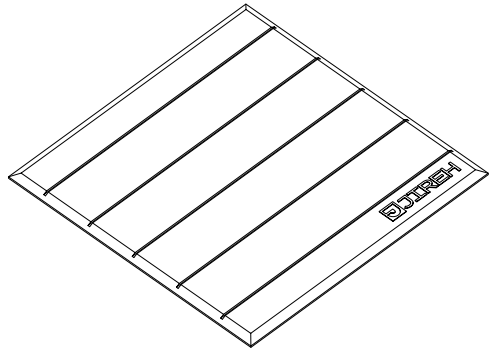

Fig. 27 - Installation/removal mat

#### 4.1.10. Lifting Sling EA243

The lifting sling (Fig. 28) attaches to the crawler, providing an attachment point for tethers. When operating a **SKOOT** at a height greater than 2 m (6 ft), the crawler **MUST** be tethered with a proper tether system to prevent the crawler from falling (see "Preparation for Safe Use" on page 32).

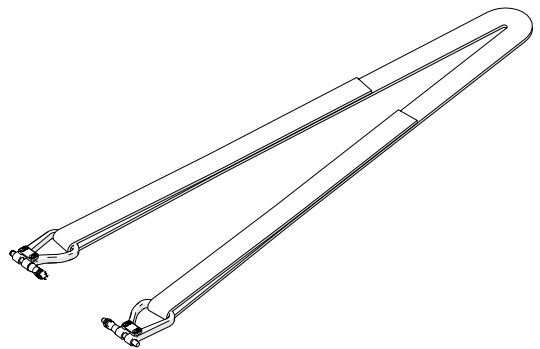

Fig. 28 - Lifting sling

#### 4.1.11. Irrigation Kit CMG009-

The irrigation kit provides a variety of hoses, fittings, connectors and splitters commonly used during non-destructive inspection (*Fig. 29*).

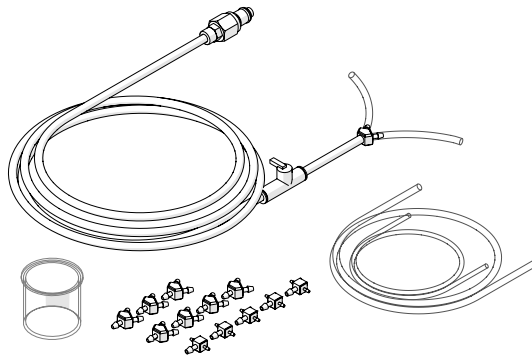

Fig. 29 - Irrigation kit

#### 4.1.12. Cable Management CXS046-

The cable management provides a means of protecting and organizing cables, tubes and hoses (*Fig. 30*).

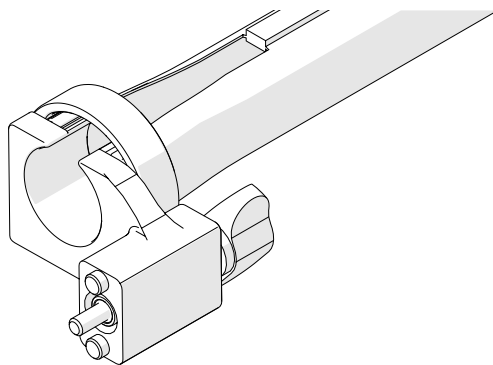

Fig. 30 - Cable management

#### 4.1.13. Battery DVA001

The battery is compatible with the power controller and will power the NAVIC system for hours at a time (*Fig. 31*).

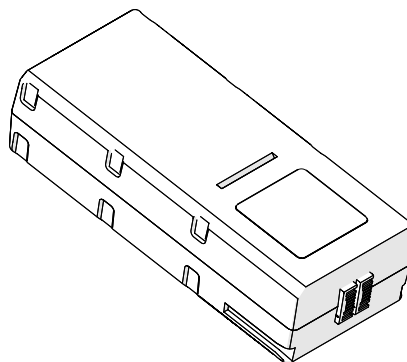

Fig. 31 - Battery

#### 4.1.14. Charger and Power Adapter DVG002-

The charger and power adapter are used to charge the batteries (Fig. 32).

#### 4.1.15. Tools

Several tools are included for various scanner and accessory adjustments (see "Tools" on page 31 for additional details).

#### 4.1.16. Cases

Depending on the configuration selected at the time of purchase. This will determine the types and amount of cases included with the system.

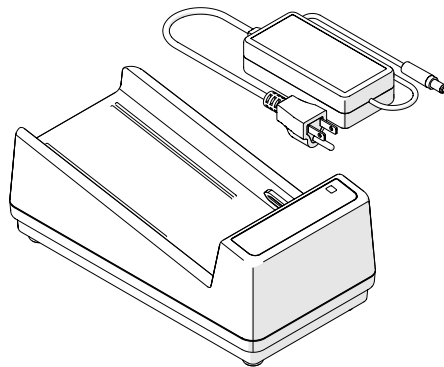

Fig. 32 - Charger and Power Adapter

## 4.2. Compatible Components

### 4.2.1. Low Profile Probe Holder Frame CXG004-

The low profile probe holder frame (*Fig. 33*) carries up to four probes during limited access and circumferential weld inspection. Removal of the **SKOOT** handles and using the low profile probe holder frame allows inspection when radial clearance is limited.

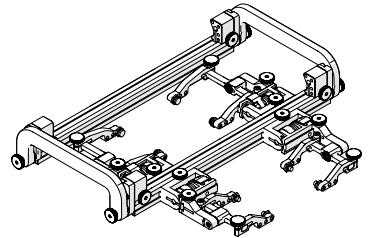

Fig. 33 - Low profile probe holder frame

### 4.2.2. Vertical Probe Holder Frame CXG007-

The vertical probe holder frame (*Fig. 34*) carries up to six probes during circumferential weld inspection. Available in a myriad of configurations and lengths, the vertical probe holder frame attaches to the front of the **SKOOT** crawler.

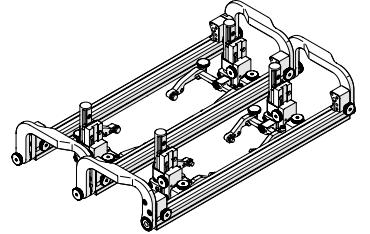

Fig. 34 - Vertical probe holder frame

### 4.2.3. Pivoting Probe Holder Frame CXG013-

The pivoting probe holder frame (*Fig. 35*) carries up to six probes during longitudinal weld inspection. Available in various configurations and lengths, the pivoting probe holder frame may also be used for circumferential weld inspection.

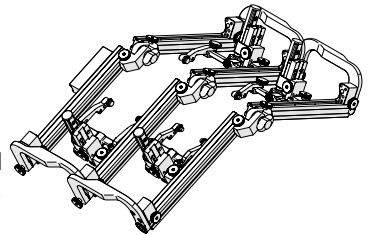

Fig. 35 - Pivoting probe holder frame

### 4.2.4. Frame Bar BG0038-

Frame bars use dovetail grooves into which probe holders and accessories may be attached (*Fig. 36*). Available in various lengths.

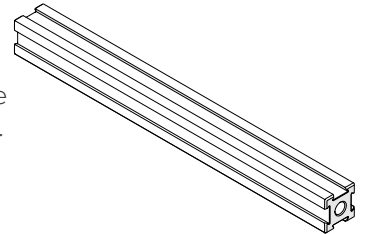

Fig. 36 - Frame bar

#### 4.2.5. Slip Joint Probe Holder PHA012-

The slip joint probe holder is generally used during limited access inspection. The low profile design requires minimal radial clearance. The slip joint probe holder is designed to carry many types of probes and wedges. It is available with various yokes, arms and pivot buttons (*Fig. 37*).

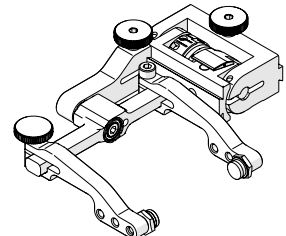

Fig. 37 - Slip joint probe holder

#### 4.2.6. Vertical Probe Holder PHA015-

The vertical probe holder (*Fig. 38*) is designed to carry many types of probes and wedges. Available with various yokes, arms and pivot buttons. The vertical probe holder features several different adjustments for each unique probe/wedge setup.

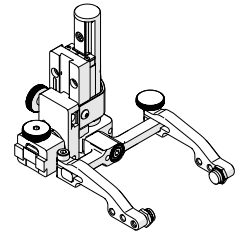

Fig. 38 - Vertical probe holder

#### 4.2.7. Heavy Duty Vertical Probe Holder PHS043-

The heavy duty vertical probe holder (*Fig. 39*) is designed to carry larger probes. Available with various arm, yoke and pivot buttons, the heavy duty vertical probe holder exerts more downforce on a large footprint probe/wedge.

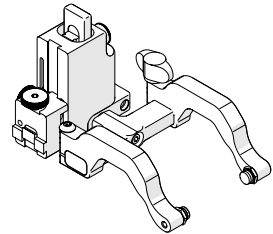

Fig. 39 - Heavy duty vertical probe holder

#### 4.2.8. Corrosion Thickness Probe Holder PHS046- / PHS056-

The corrosion thickness probe holder (*Fig. 40*) carries various probes for f corrosion inspection and is available with either a flat or curved wear plate.

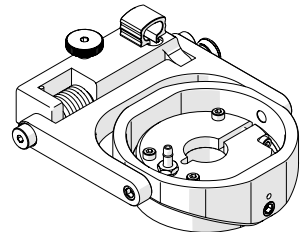

Fig. 40 - Corrosion thickness probe holder

#### 4.2.9. HydroFORM Cart PHS044

The HydroFORM Cart (*Fig. 41*) carries an Olympus HydroFORM™ probe. The HydroFORM cart is designed to be used with the heavy duty vertical probe holder.

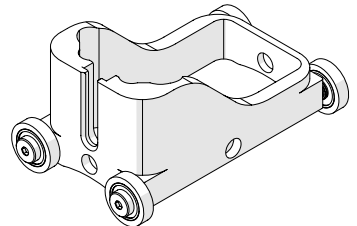

Fig. 41 - HydroFORM cart

#### 4.2.10. Preamp Bracket CES029-

The preamp mounts to any dovetail groove. It is compatible with most standard preamps (*Fig. 42*).

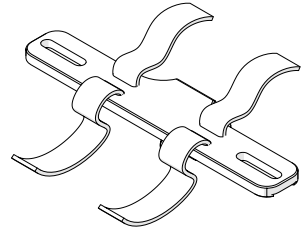

Fig. 42 - Preamp bracket

#### 4.2.11. Battery Powered Optical Guide CXS080

The battery-powered optical guide (*Fig. 43*) provides a red colour point of reference helpful for guiding scanners along a given path (*i.e. a weld*).

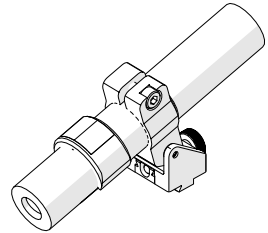

Fig. 43 - Battery powered optical guide

#### 4.2.12. Automated Crawler Medium Temperature Add-On Kit CXG031-

The automated crawler medium temperature add-on kit (*Fig. 44*) enables a **SKOOT** crawler to operate on an inspection surface with a temperature up to 150°C (302°F).

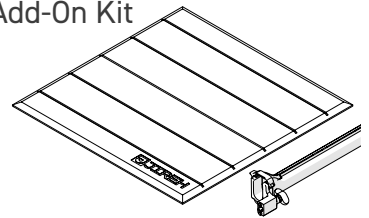

Fig. 44 - Automated crawler medium temperature add-on kit

#### 4.2.13. Encoder Adapter UMA010-

The encoder adapter changes the scanner's built-in encoder connector style (*Fig. 45*).

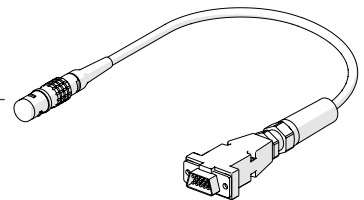

Fig. 45 - Encoder adapter



## 4.3. Child Products

### 4.3.1. Motorized Couplant Pump CMA015

The motorized couplant pump is a powered pumping unit that supplies couplant fluid to the scanning surface (*Fig. 46*).

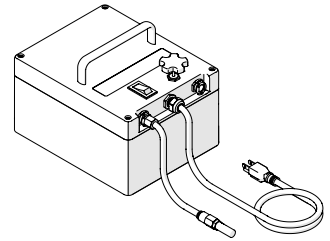

Fig. 46 - Motorized couplant pump

### 4.3.2. Motorized Raster Arm CWG002-

The motorized raster arm is available in various lengths and offers programmable speed and travel settings (*Fig. 47*).

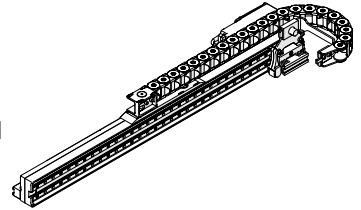

Fig. 47 - Motorized raster arm

### 4.3.3. Optical Guide CXG035

The optical guide (*Fig. 48*) mounts to any dovetail and provides a green colour point of reference useful for guiding scanners along a given path (*i.e. a weld*).

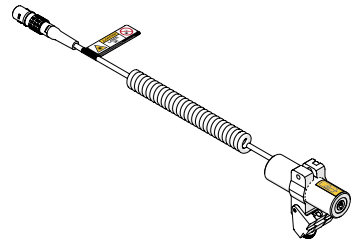

Fig. 48 - Optical guide

### 4.3.4. Battery Kit DVG001-

The rechargeable battery kit (*Fig. 49*) provides portable power to the crawler and components (*i.e. motorized raster arm*).

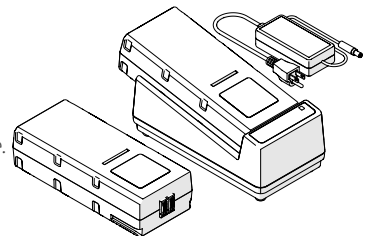

Fig. 49 - Battery kit

### 4.3.5. Preamp Kit CXG040-

The Preamp amplifies the return signal from an ultrasonic transducer to improve the signal-to-noise ratio for transmission over long cables (*Fig. 50*).

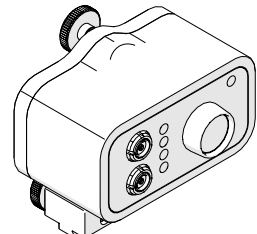

Fig. 50 - Preamp kit

## 4.4. Tools

### 4.4.1. Included Tools

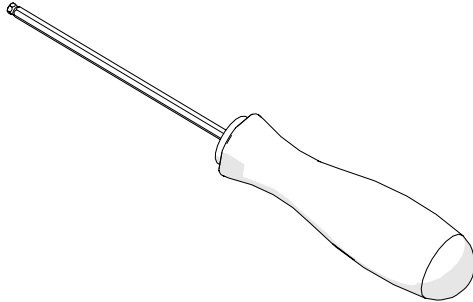

Fig. 51 - 3 mm hex driver

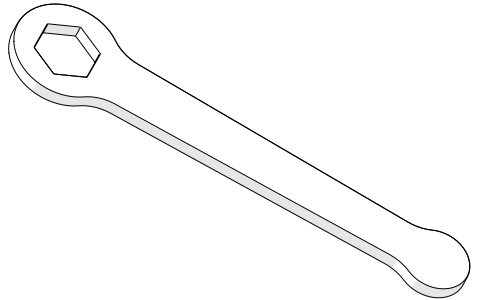

Fig. 52 - 3/8 in wrench

The included 3 mm hex driver (*Fig. 51*) is suitable for typical **SKOOT** and probe holder adjustments.

A 3/8 in wrench (*Fig. 52*) is provided to remove and install probe holder buttons.

The included 3 mm flat driver (*Fig. 53*) is useful for releasing the flaps of the raster arm's cable tray.

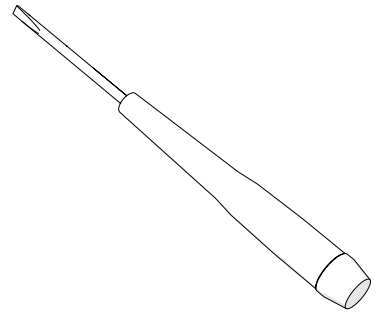

Fig. 53 - 3 mm flat driver

### 4.4.2. Optional tools

Some specialized adjustments require tools that are not included with this kit.

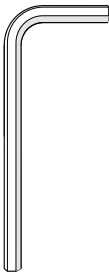

Fig. 54 - 1.5 mm hex wrench

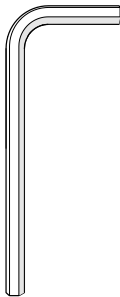

Fig. 55 - 2 mm hex wrench

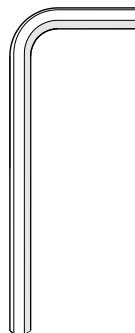

Fig. 56 - 3 mm hex wrench

## PREPARATION FOR USE

### 5.1. Preparation for Transportation



**CAUTION!** PINCH / CRUSH HAZARD. BE CAREFUL when passing the SKOOT crawler through narrow ferrous (*magnetic*) openings, such as man-holes. The magnetic drive wheels can cause bodily harm if allowed to slam onto the walls of the opening.

### 5.2. Preparation for Safe Use

#### 5.2.1. No Entry Fall Zone



**WARNING!** FALLING OBJECT HAZARD. The area below a crawler must be kept clear at all times. A clearly marked **NO ENTRY FALL ZONE** must be cordoned off directly below the area of crawler operation.

The area below a crawler must be kept clear at all times. A clearly marked **NO ENTRY FALL ZONE** must be cordoned off directly below the area of crawler operation, according to the dimensions shown in (Fig. 57).

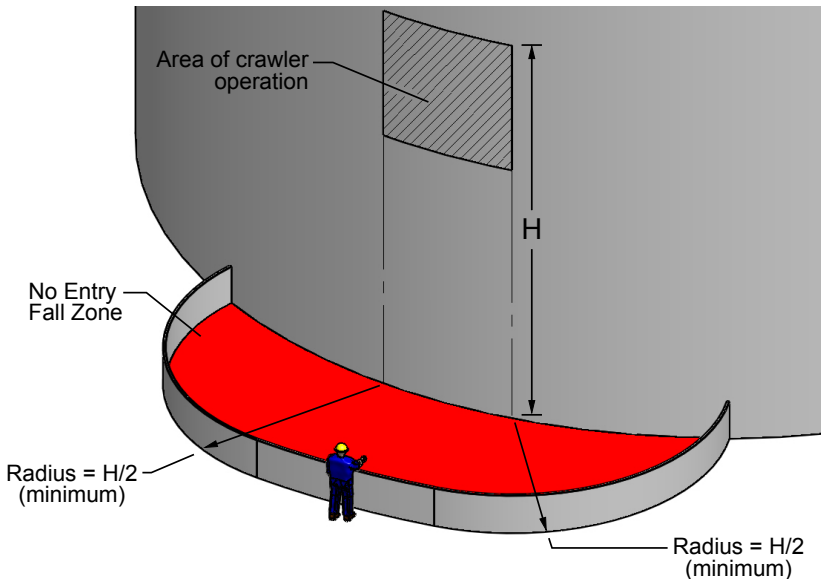

Fig. 57 - No entry fall zone

Example: If inspecting a tank that is 6 m (20 ft) tall, the No Entry Fall Zone radii must be no smaller than 3 m (10 ft) from the area below the area of crawler operation.

## 5.2.2. Tether Requirements and Attachment



### **WARNING!** FALLING OBJECT HAZARD.

Failure to comply with the warnings, instructions, and specifications in this manual could result in **SEVERE INJURY** or **DEATH**.

**WARNING!** Do **NOT** operate or place crawler on a surface higher than 2 m (6 ft) without a proper tether held taut at all times.

**WARNING!** Hook the tether hook to the provided lifting sling **BEFORE** placing the crawler on the surface to be inspected (*e.g. tank*).

**IMPORTANT:** Tether hook must have a safety latch to prevent accidental disconnection.

When used at a height greater than 2 m (6 ft), the **SKOOT** crawler **MUST** be tethered with a proper tether system to prevent the crawler from falling. The tether system must:

- ▶ be capable of safely suspending the crawler from above in case the crawler detaches from the inspection surface;
- ▶ have sufficient capacity to catch and hold a 70 kg (150 lb) load;
- ▶ include a mechanism (*i.e. self retracting inertia reel fall arrester*) or person to continuously take up slack in the tether as the crawler moves;
- ▶ include a lifting hook with a safety latch to prevent accidental disconnection. The hook must be free of sharp edges that may cut or abrade the provided lifting sling.

Before placing the crawler on the surface to be inspected (*e.g. tank*), attach the provided lifting sling to the **SKOOT** and then hook the tether hook to the lifting sling.



**CAUTION!** The overhead attachment point for the tether must be located as close as possible to a location directly above the crawler to minimize dangerous swinging of the crawler should it detach from the inspection surface.

### 5.2.3. Lifting Sling Setup



**IMPORTANT!** Carefully inspect the lifting sling for damage prior to each use. Ensure the tether hook does not have sharp edges that may cut the lifting sling.

Secure the lifting sling to the **SKOOT** as illustrated here:

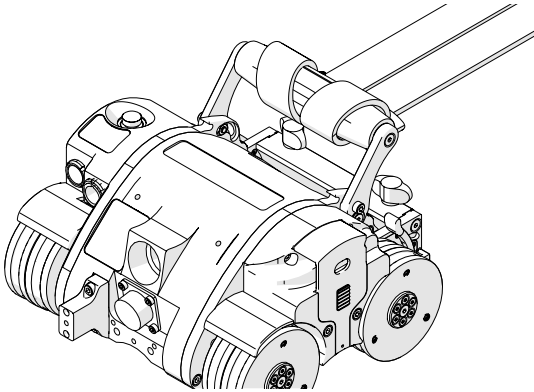

Fig. 58 - Attach the lifting sling with a choker hold

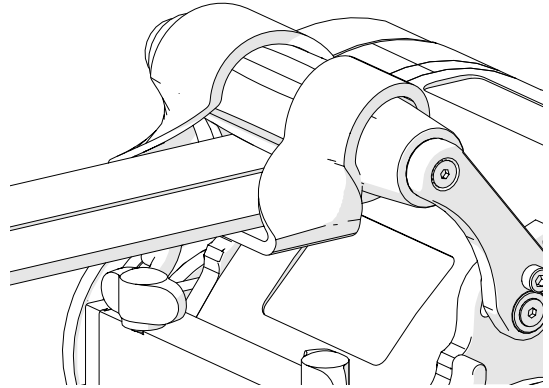

Fig. 59 - Attach the lifting sling with a choker hold

1. Wrap the supplied lifting sling around the handle of the **SKOOT** using a choker hold knot (Fig. 58) and (Fig. 59).
2. Ensure the lifting sling is attached correctly to the **SKOOT** and inspect the lifting sling for any damage prior to use.

### 5.3. Preparation of Inspection Surface



**WARNING! FALLING OBJECT HAZARD.** The inspection surface must adhere to the conditions outlined in sections “Intended Use” on page 3 and “Operating Environment” on page 5 of this manual.

- ▶ Remove build-up of scale, and other debris (i.e. dirt, ice) from surface on which the crawler is to drive. Excessive build-up will cause the wheels to lose magnetic attraction which may lead to wheel slippage or crawler detachment.
- ▶ Ensure that no obstructions (other than standard butt welds) or voids are in the drive path. Obstructions and voids could cause the crawler to fall if driven into or over.
- ▶ Ensure that there are no patches of non-ferrous material in the drive path of the crawler. If the crawler drives over a non-ferrous patch, it will lose magnetic attraction and will cause the crawler to fall.

## 5.4. System Connectivity

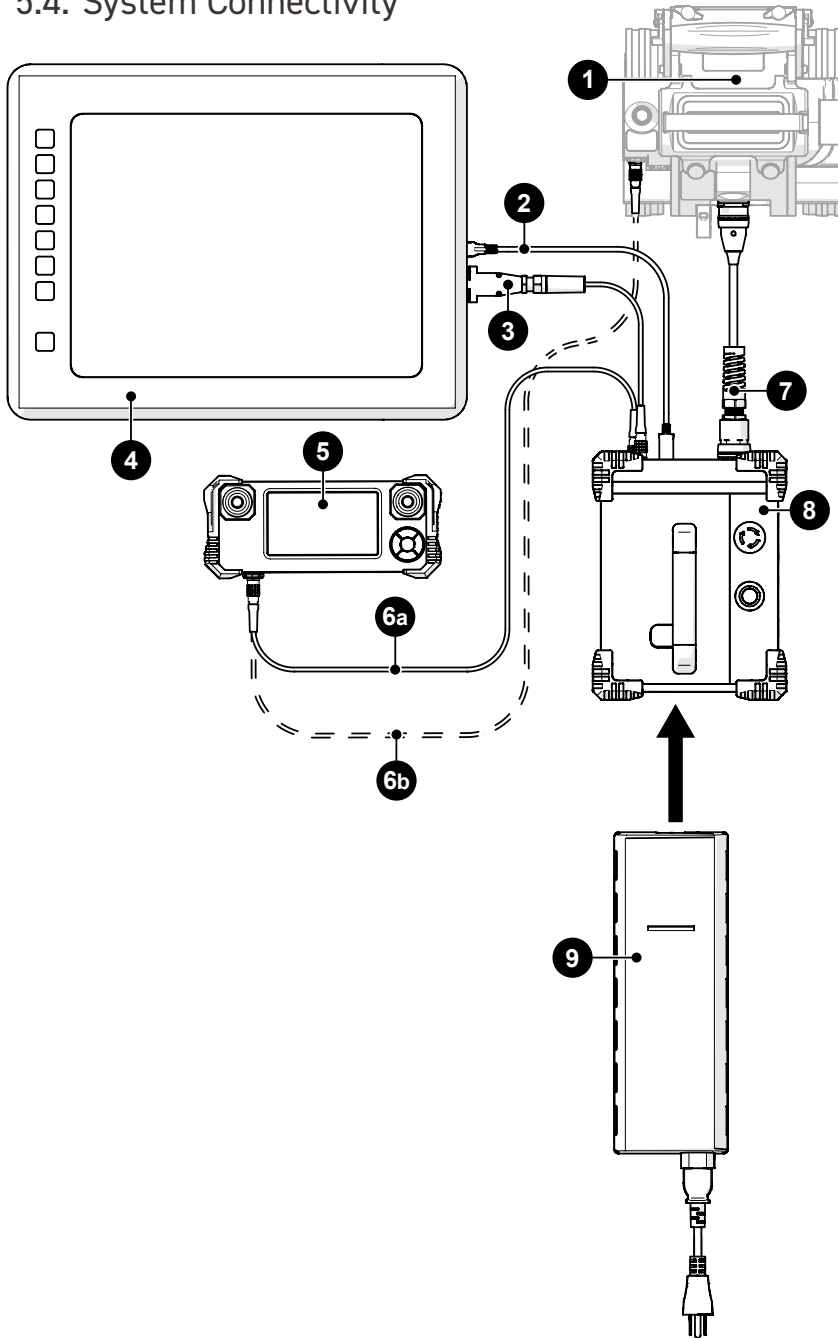



Fig. 60 - Standard crawler configuration

BOM ID	Description
1	Crawler
2	Scanlink™ cable
3	Encoder cable
4	User instrument
5	Handheld controller
6a	Auxiliary cable
6b	Auxiliary cable ( <i>alternate</i> )
7	Umbilical
8	Power controller
9	AC/DC power supply

To configure the **SKOOT** system for scanning, follow these steps:



**CAUTION! DO NOT DISCONNECT UNDER LOAD.** Shut off power before connection or disconnecting. Permanent damage to electronics could occur.



1. Connect the **8** power controller to the **1** crawler using the **7** umbilical.
2. Connect the **5** handheld controller to the **8** power controller using the **6a** auxiliary cable.

**NOTE:** The **5** handheld controller may also be connected directly to the **1** crawler using the **6b** auxiliary cable.

3. Connect the **4** user's instrument to the **8** power controller using the **3** encoder cable.
4. Insert **9** AC/DC power supply into the **8** power controller.
5. (see "Configurations" on page 37) to set up a particular component.

# 5.5. Configurations

## 5.5.1. Crawler with Multiple Probe Holders

### 5.5.1.1 Vertical Probe Holder Frame

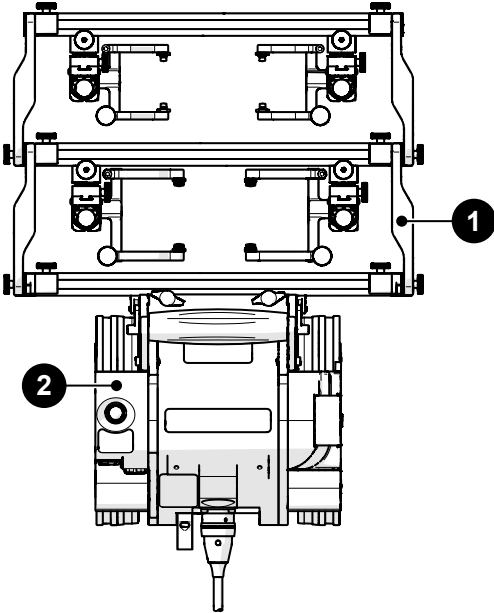

Fig. 61 - Probe holder frame configuration

BOM ID	Description
1	Vertical probe holder frame
2	Crawler



To configure the **SKOOT** system for scanning using a vertical probe holder frame, follow these steps (see “Vertical Probe Holder Frame - Flat or Circumferential Only” on page 74):



**CAUTION! DO NOT DISCONNECT UNDER LOAD.** Shut off power before connection or disconnecting. Permanent damage to electronics could occur.



1. Attach a configured **1** vertical probe holder frame to the **2** crawler.

5.5.1.2 Low Profile Probe Holder Frame

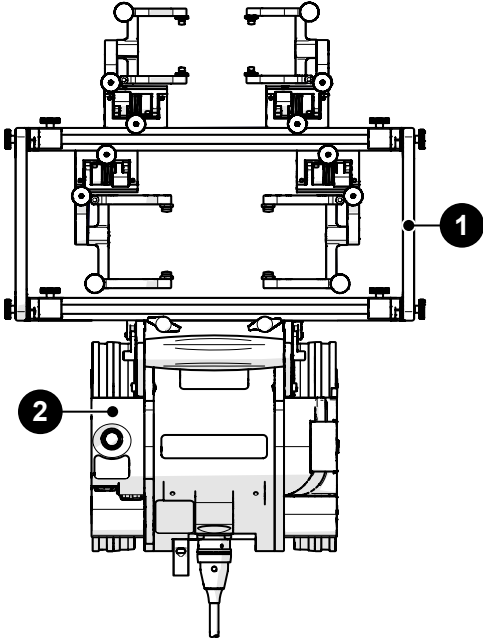

Fig. 62 - Low profile probe holder frame configuration

BOM ID	Description
1	Low profile probe holder frame
2	Crawler

To configure the **SKOOT** system for scanning using a low profile probe holder frame, follow these steps (see “*Low Profile Probe Holder Frame - Flat or Circumferential Only*” on page 70):



**CAUTION! DO NOT DISCONNECT UNDER LOAD.** Shut off power before connection or disconnecting. Permanent damage to electronics could occur.



1. Attach a configured **1** low profile probe holder frame to the **2** crawler.

5.5.1.3 Pivoting Probe Holder Frame

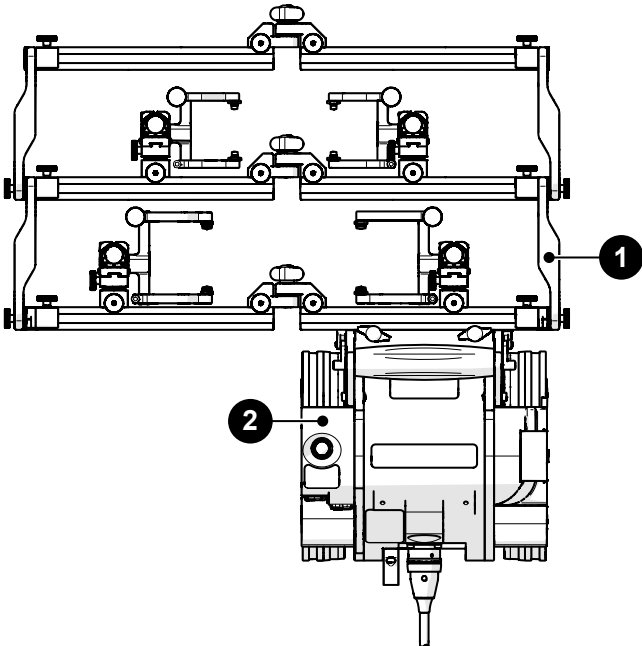

Fig. 63 - Pivoting probe holder frame configuration

BOM ID	Description
1	Pivoting probe holder frame
2	Crawler

To configure the **SKOOT** system for scanning using a pivoting probe holder frame, follow these steps (see “Pivoting Probe Holder Frame” on page 78):



**CAUTION! DO NOT DISCONNECT UNDER**

**LOAD.** Shut off power before connection or disconnecting. Permanent damage to electronics could occur.



1. Attach a configured **1** pivoting probe holder frame to the **2** crawler.

5.5.1.4 Flange

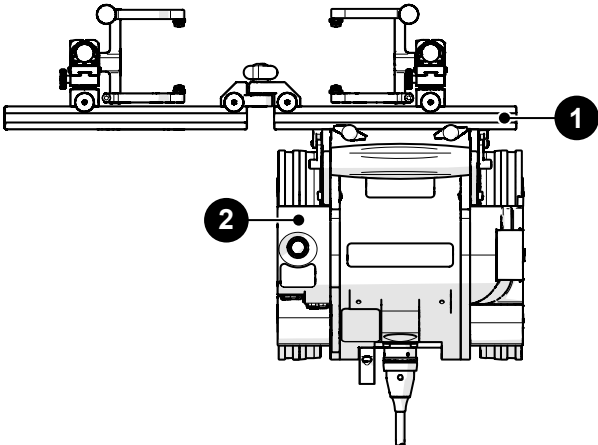

Fig. 64 - Pivoting probe holder frame configured for flange scanning

BOM ID	Description
1	Flange probe holder frame
2	Crawler

To configure the **SKOOT HT** system for scanning using a pivoting probe holder frame configured for flange scanning, follow these steps (see “*Pivoting Probe Holder Frame - Flange Scanning*” on page 82):



**CAUTION! DO NOT DISCONNECT UNDER LOAD.** Shut off power before connection or disconnecting. Permanent damage to electronics could occur.



1. Attach a configured **1** flange probe holder frame to the **2** crawler.

## 5.6. Crawler

### 5.6.1. Swivel Mount

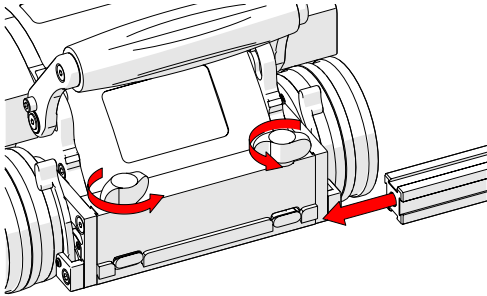

Fig. 65 - Frame bar installation

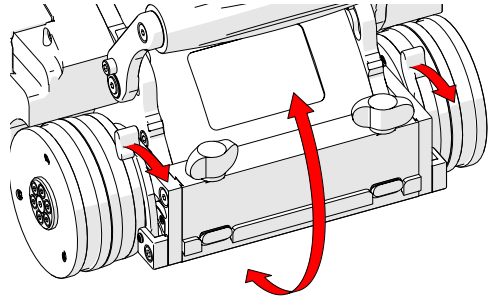

Fig. 66 - Swivel mount angle

Located at the front of the crawler, the swivel mount connects scanning accessories such as a raster arm module, probe frame system or corrosion thickness probe holder.

Rotate the two black wing knobs (*Fig. 65*) to loosen the dovetail jaws. Slide the accessory's frame bar along the dovetail jaws. Rotate the two black wing knobs to clamp the frame system/raster arm in place.

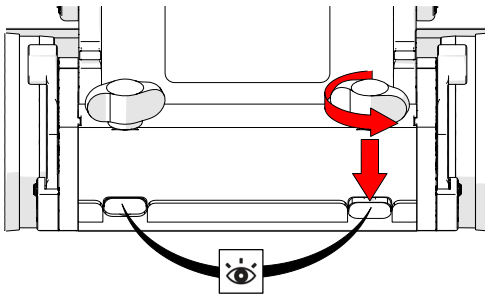

Fig. 67 - Align dovetail jaws

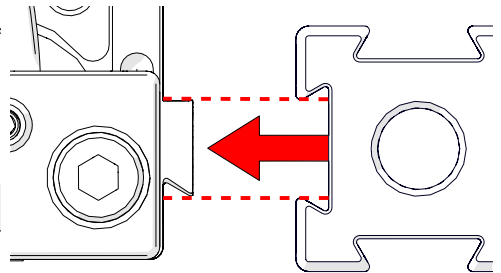

Fig. 68 - Mount frame bar

Alternatively, accessories can also be mounted straight to the swivel mount. Rotate the black wing knobs aligning the dovetail jaws with the mount's grooves (*Fig. 67*). Press the frame bar or accessory to the swivel mount (*Fig. 68*) and tighten the black wing knobs.

The front mount utilizes two levers (*Fig. 66*) to lock the front mount at the desired angle.



The etched line (Fig. 69) near the base of the swivel mount can be used to align the front swivel mount to a horizontal position.

**NOTE:** The front mount must be horizontal when using the pivoting probe holder frame to scan longitudinally on piping.

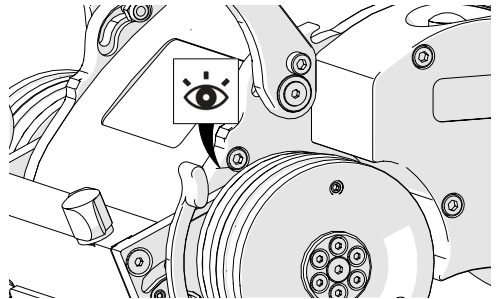

Fig. 69 - Return mount to horizontal position

## 5.6.2. Umbilical



**WARNING! FALLING OBJECT HAZARD.** or operating at heights greater than 2 m (6 ft), ensure the umbilical strain relief never points upwards as shown in (Fig. 73). The crawler could fall. **SEVERE INJURY** or **DEATH** could result.

To mount the umbilical to the crawler, follow these steps:

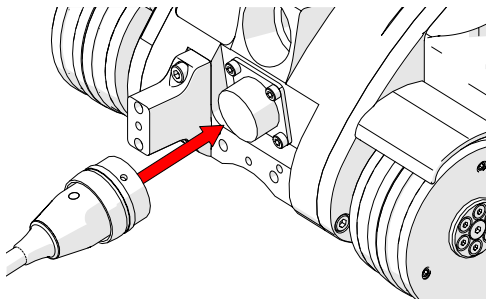

Fig. 70 - Connect to umbilical

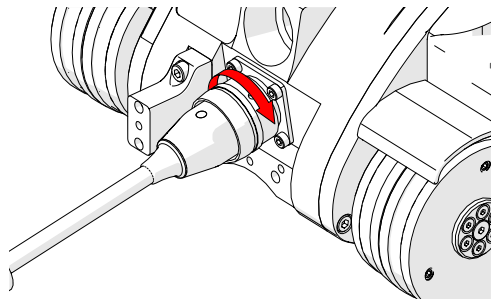

Fig. 71 - Align with crawler's umbilical mount

1. Align the pins of the umbilical to the connector at the rear of the **SKOOT** (Fig. 70).
2. Twist the umbilical's sleeve clockwise, locking the umbilical in place (Fig. 71).

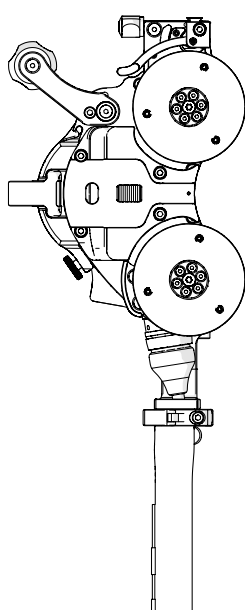

Fig. 72 - Correct umbilical use

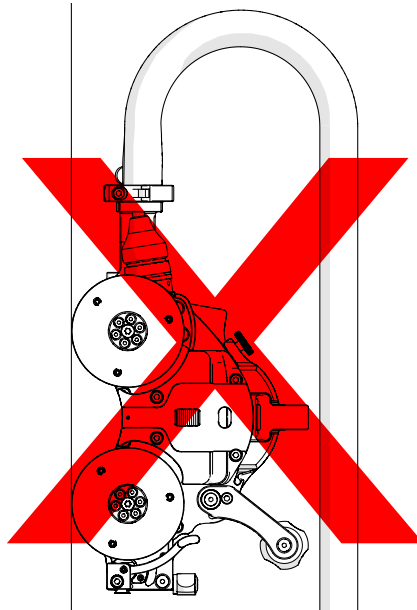

Fig. 73 - Incorrect umbilical use

3. Ensure the umbilical strain relief never points downwards during operation (Fig. 73).

### 5.6.3. Handle

The handle can be lowered to achieve low profile scanning.

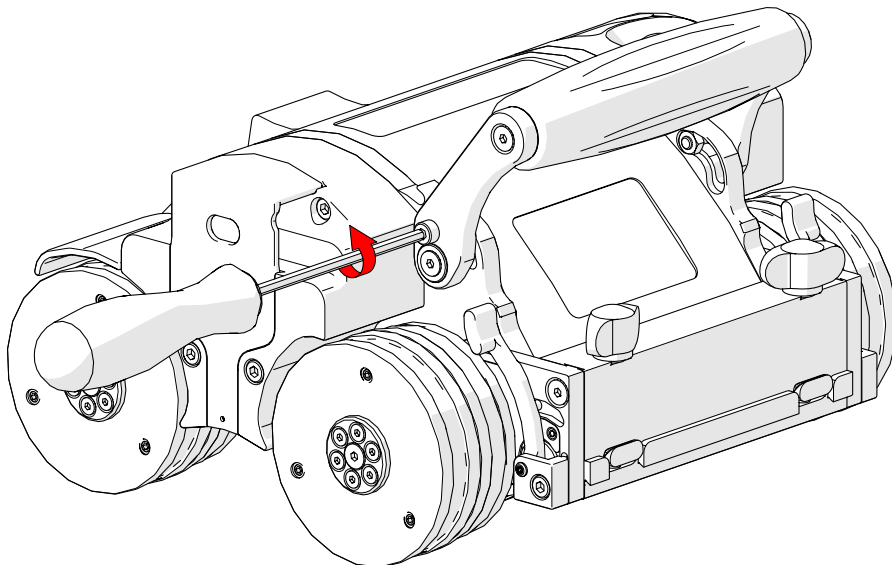

Fig. 74 - Unscrew handle lock screw

1. To lower the handle, use the supplied 3 mm driver to loosen the handle lock screws on either side of the handle (Fig. 74).

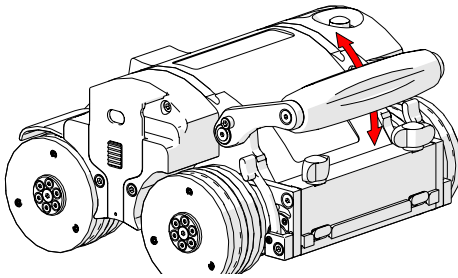

Fig. 75 - Pivot handle as desired

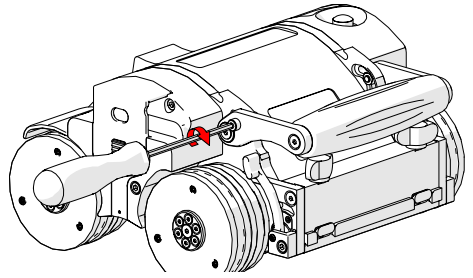

Fig. 76 - Tighten lock screws

2. Pivot the handle as required (Fig. 75).
3. Tighten the handle lock screws when complete (Fig. 76).

#### 5.6.4. Stop Button

The red button on the top left of the crawler provides a stop button to the entire system. When pressed, all power to the **SKOOT** system will disengage.

To restore system power, it is necessary to press the power button located on the power controller (see “Power Controller” on page 20).

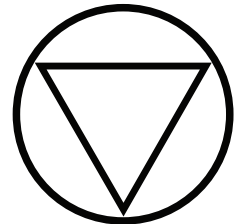

Fig. 77 - Stop

**NOTE:** Terminating system power may cause the crawler to freewheel down when operating in a vertical orientation.

#### 5.6.5. Cable Retainer

Located on the side of the crawler, the cable retainer offers a means of cable management for cables, hoses and tubes. Gently apply pressure to the grooves of the cable retainer and lift (Fig. 78). Route cables, hoses or tubes through the retainer and then press the cable retainer down (Fig. 79).

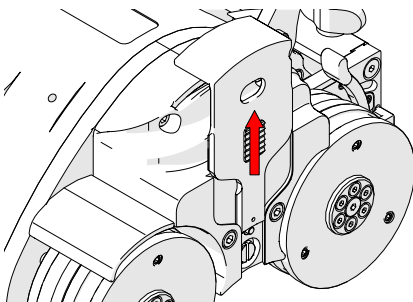

Fig. 78 - Lift retainer by hand

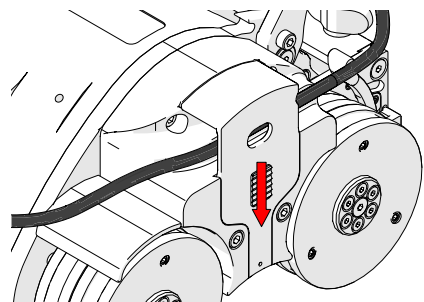

Fig. 79 - Place cables and hoses then close retainer

## 5.6.6. Manipulation Handle

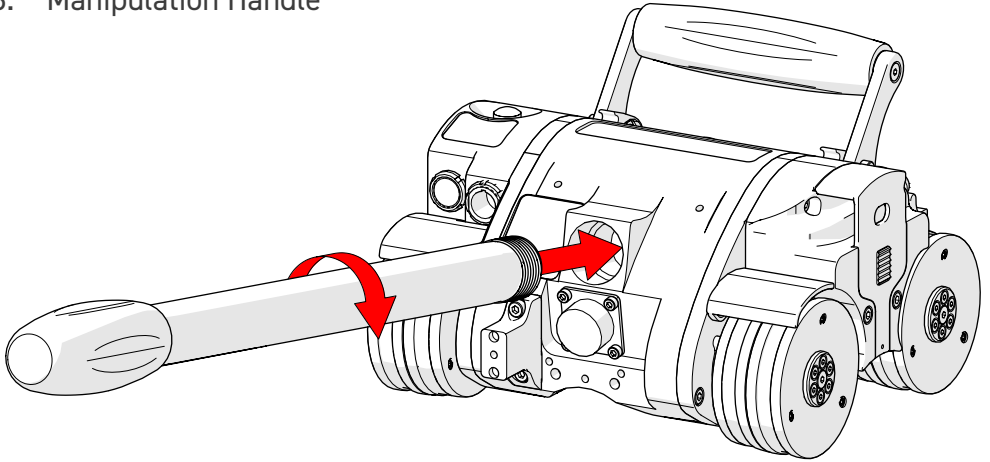

Fig. 80 - Manipulation handle

The manipulation handle (*Fig. 80*) provides a means of orienting the scanner direction. The handle can be used to set initial scanner direction and occasional orientation correction. The manipulation handle is not intended as a tool for constant adjustment during a scan operation.

The handle may be removed when additional scanner clearance is required.

**NOTE:** Do not use the manipulation handle to remove or install a crawler from a scan surface without the installation/removal mat in place.

## 5.7. Handheld Controller



**WARNING! MAGNETIC MATERIAL.** The handheld controller produces a strong magnetic field which may cause failure or permanent damage to items such as watches, memory devices, CRT monitors, medical devices or other electronics.



People with pacemakers or ICD's must stay at least 10 cm (4 in) away.



**CAUTION! DO NOT DISCONNECT UNDER LOAD.** Shut off power before connection or disconnecting. Permanent damage to electronics could occur.



### 5.7.1. Magnetic Mounts

Magnetic mounts on the rear of the handheld controller assist in preventing the handheld controller from falling.

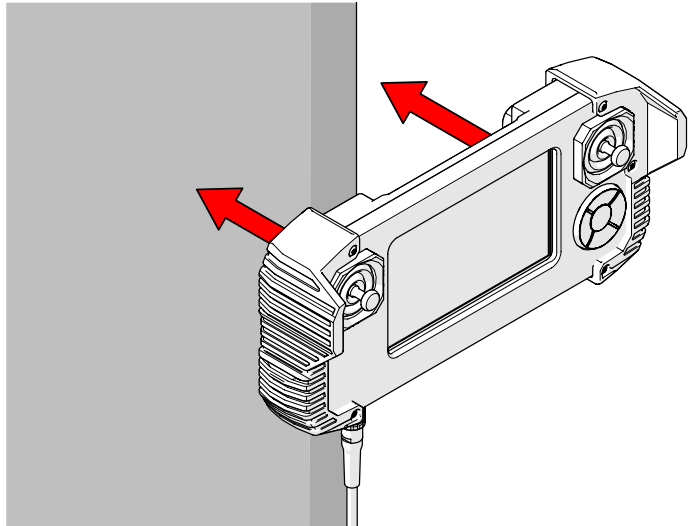

Fig. 81 - Mount to ferrous surfaces

## 5.8. Backpack

The **SKOOT** backpack provides a mounting point for scanning peripherals. The flexible strap securely holds any preamp, splitters or scan accessories to the **SKOOT** crawler.

### 5.8.1. Mounting a Backpack

To mount the backpack, follow these steps.

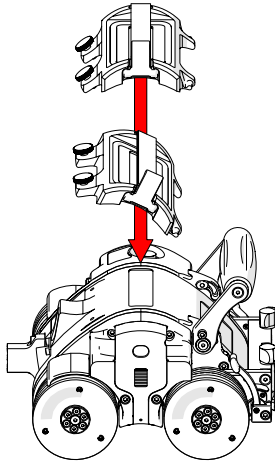

Fig. 82 - Angle backpack

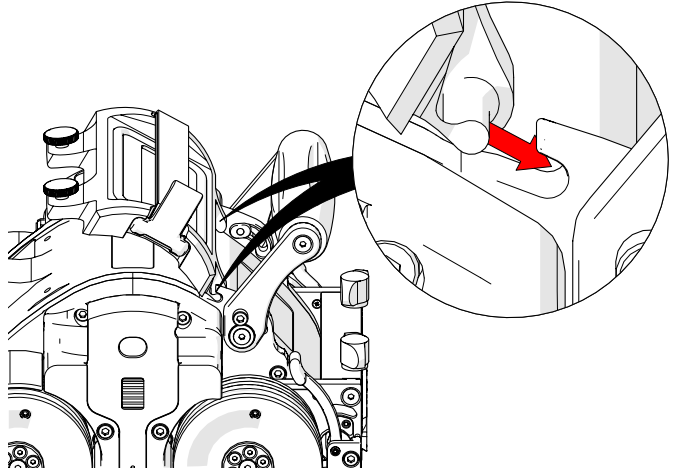

Fig. 83 - Fit backpack into notches

1. Angle the backpack (Fig. 82) towards the notches found on the **SKOOT** (located near the base of the handle).
2. Place the front of the backpack into the notches found near the base of the handle (Fig. 83).
3. Lower the backpack to the **SKOOT** and tighten the thumb screws to secure the backpack (Fig. 84).

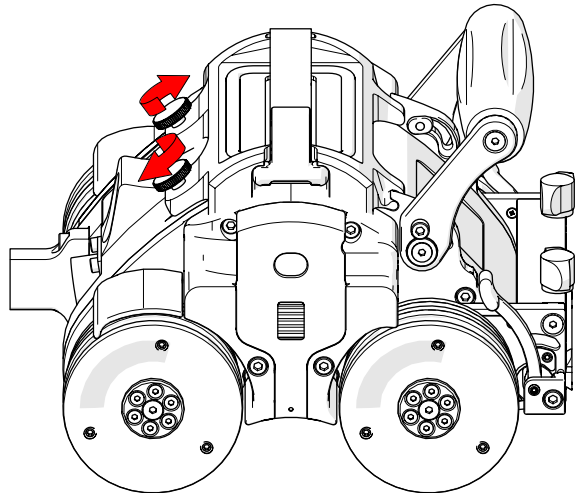

Fig. 84 - Tighten thumb screws

## 5.8.2. Using the backpack

The flexible strap of the backpack stretches to hold various scanning accessories to a crawler.

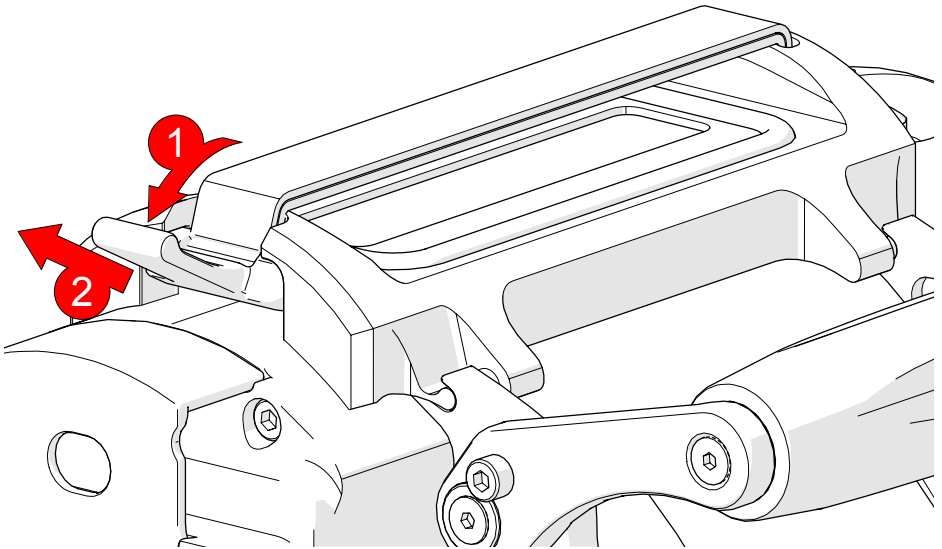

Fig. 85 - Press lever down and pull to release

1. Press the strap's lever down (*Fig. 85-1*) and then pull (*Fig. 85-2*) to release the flexible strap.

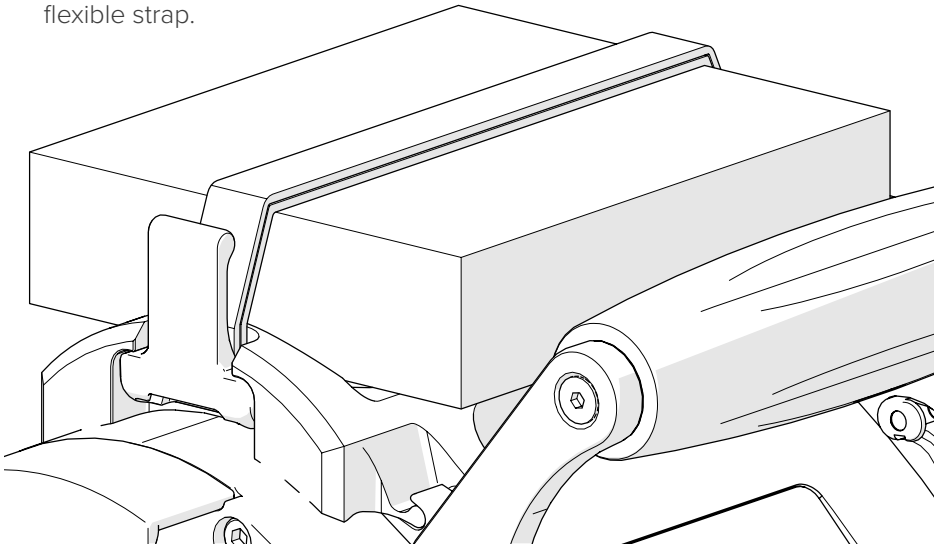

Fig. 86 - Press lever into backpack to lock in place

2. Place the scanning accessory on the backpack. Pull the strap lever across the accessory and fit the lever into place on the backpack (*Fig. 86*).

## 5.9. Probe Holders

### 5.9.1. Heavy Duty Vertical Probe Holder

- A Latch
- B Probe Holder Arm Adjustment Knob
- C Yoke
- D Probe Holder Arms
- E Pivot Buttons
- F Arm Clamp Screw
- G Probe Holder Adjustment Knob
- H Vertical Adjustment Knob

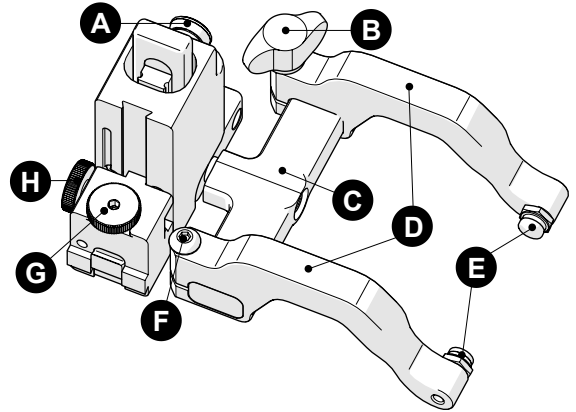

Fig. 87 - Heavy duty vertical probe holder

#### 5.9.1.1 Probe Holder Setup

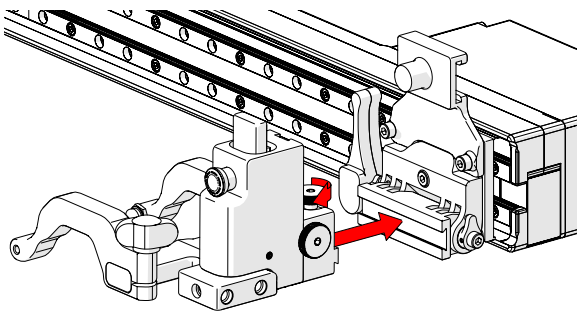

Fig. 88 - Mount probe holder to carrier

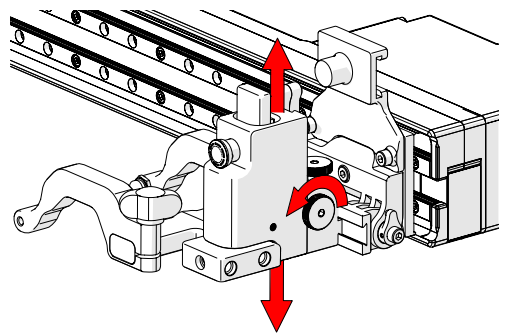

Fig. 89 - Vertical adjustment

1. Loosen the probe holder adjustment knob (*Fig. 88*) and mount the heavy duty vertical probe holder's dovetail jaw to the carrier.
2. The vertical adjustment knob (*Fig. 89*) allows the heavy duty vertical probe holder's height adjustment. This adjustment also controls the probe holder's spring tension.



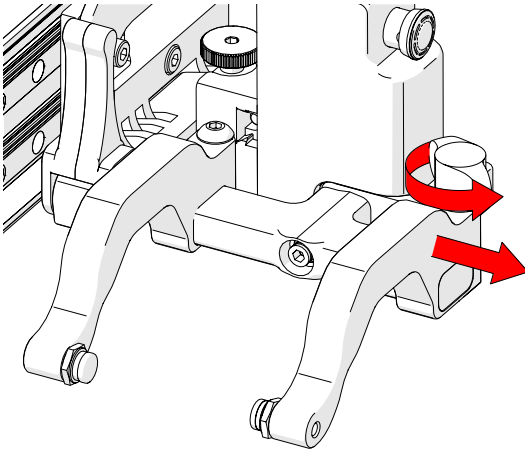

Fig. 90 - Remove outer arm

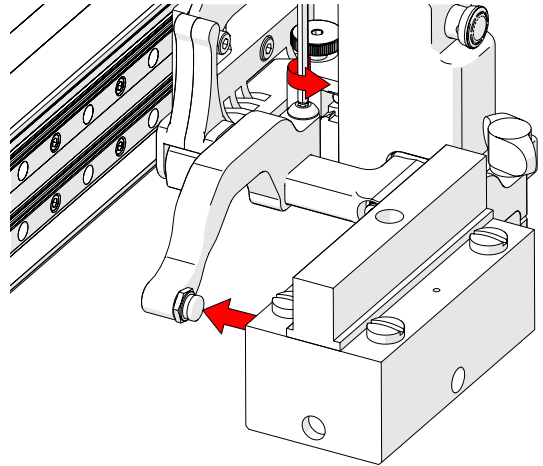

Fig. 91 - Adjust inner arm

3. Loosen the probe holder adjustment knob and remove the outer probe holder arm (Fig. 90).
4. Loosen the arm clamp screw (Fig. 91).
5. Place the wedge on the pivot button of the inner probe holder arm (Fig. 90).

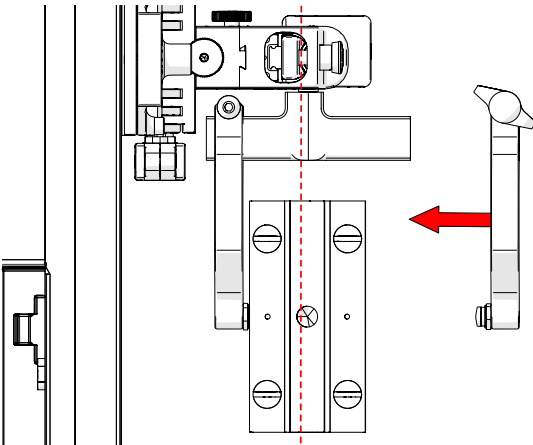

Fig. 92 - Align probe with yoke

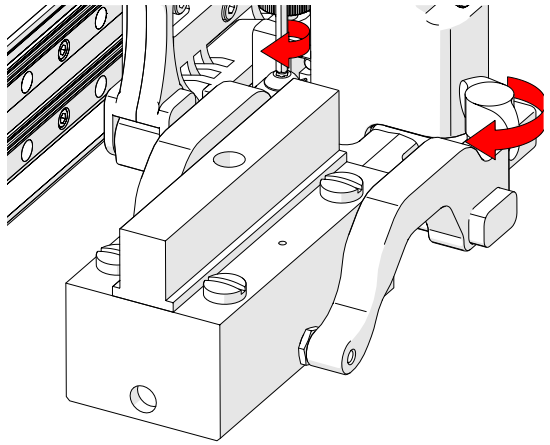

Fig. 93 - Tighten knobs and screws

6. Align the middle of the wedge with the centre of the yoke (Fig. 92).
7. Tighten the probe holder adjustment knob and the arm clamp screw (Fig. 93) while ensuring the wedge remains centred with the yoke.

### 5.9.1.2 Probe Holder Vertical Adjustment

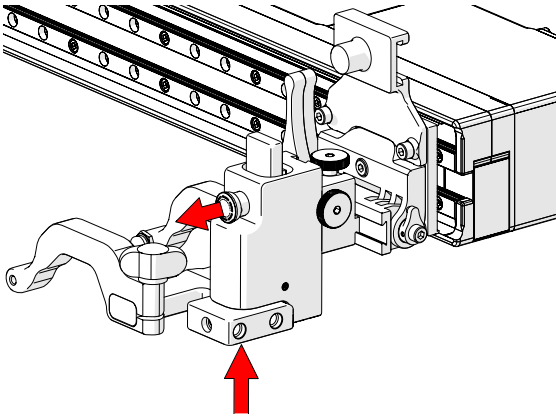

Fig. 94 - Press up and pull latch

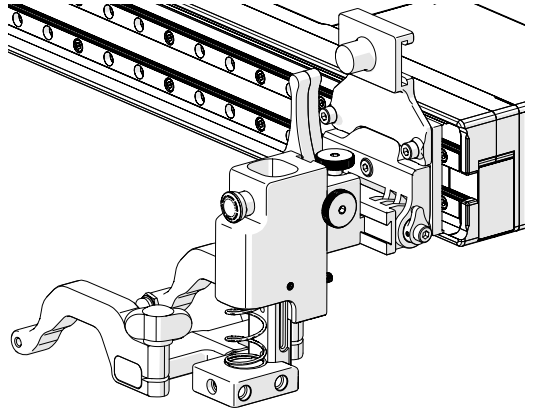

Fig. 95 - Lowered toward scan surface

1. Gently lift the heavy duty vertical probe holder and simultaneously pull the latch (*Fig. 94*). This action will unlock the probe holder. Slowly lower the probe holder towards the scan surface (*Fig. 95*).

### 5.9.1.3 Probe Holder Left/Right Conversion

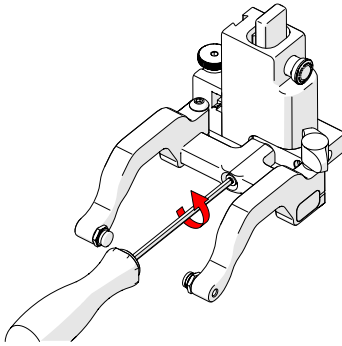

Fig. 96 - Remove yoke

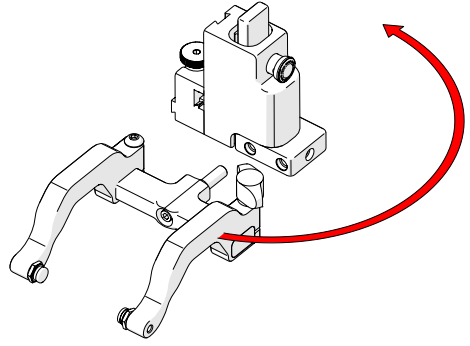

Fig. 97 - Orient to opposite side

1. Using the supplied 3 mm driver, unscrew the yoke (Fig. 96).
2. Position the yoke and arms on the opposite side of the probe holder (Fig. 97).

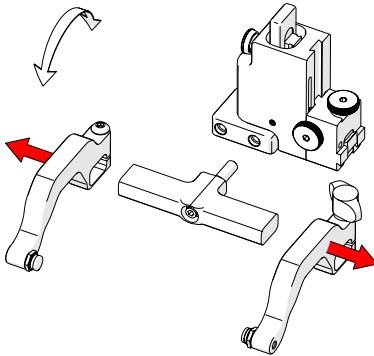

Fig. 98 - Remove probe holder arms

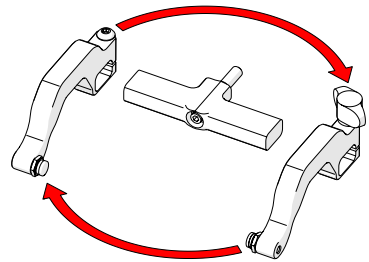

Fig. 99 - Reverse position around yoke

3. Loosen the arm clamp screw and the probe holder arm adjustment knob allowing removal of the probe holder arms (Fig. 98).
4. Position the removed arms on the opposite sides of the yoke (Fig. 99).

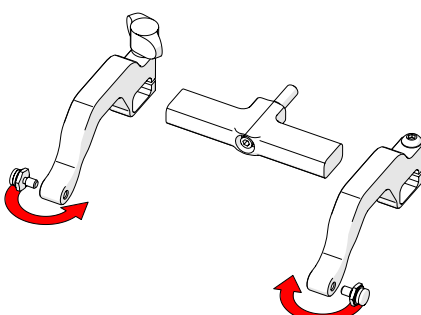

Fig. 100 - Position pivot buttons

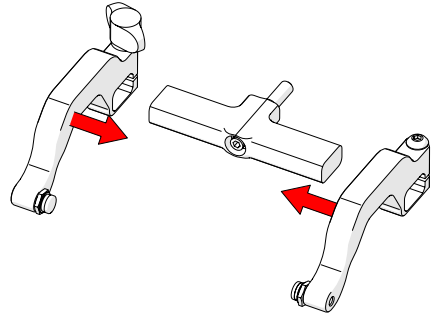

Fig. 101 - Place arms back onto yoke

5. Position the pivot buttons to the inside of the probe holder arms (Fig. 100).
6. Place the probe holder arms on the yoke and tighten the arm clamp screw and probe holder adjustment knob (Fig. 101).
7. Screw the yoke to the probe holder (Fig. 102).

**TIP:** When using a standard yoke length, position the yoke in the threaded hole closest to the frame bar. When using a long yoke length, position the yoke in the threaded hole furthest from the frame bar.

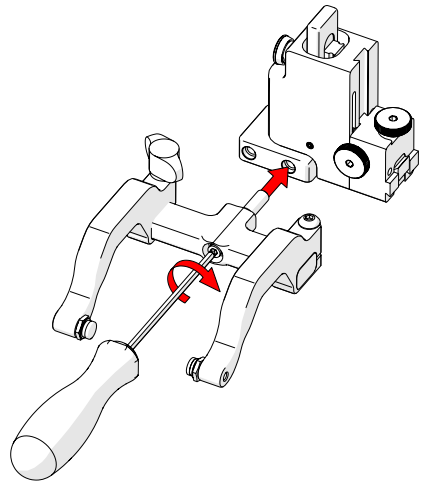

Fig. 102 - Screw into threaded hole

#### 5.9.1.4 Probe Holder 90° Adjustment

1. Remove the yoke using the supplied 3 mm hex driver (Fig. 96).
2. Orient the yoke to the front of the probe holder and screw the yoke into the threaded hole provided (Fig. 103).

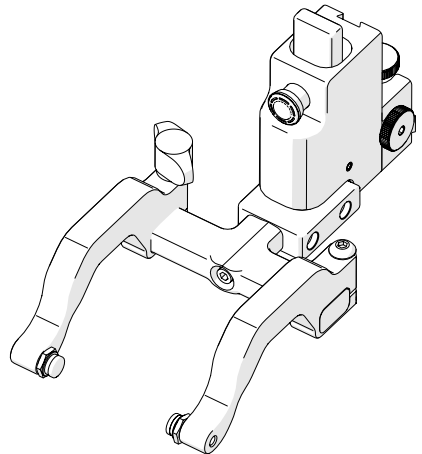

Fig. 103 - 90° probe holder positioning

## 5.9.2. Vertical Probe Holder

- A Latch
- B Probe Holder Adjustment Knob
- C Vertical Adjustment Knob
- D Pivot Buttons
- E Probe Holder Arms
- F Yoke
- G Probe Holder Arm Adjustment Knob
- H Transverse Adjustment Screw
- I Frame Bar

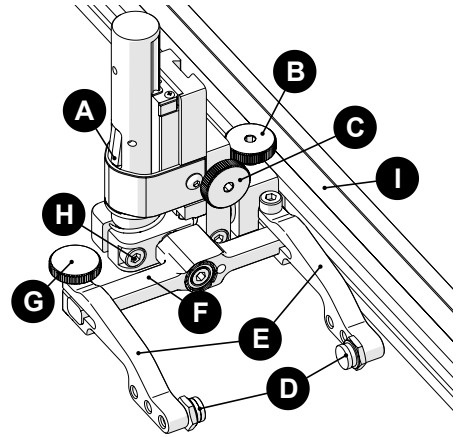

Fig. 104 - Vertical probe holder

### 5.9.2.1 Probe Holder Setup

To mount a UT wedge in the probe holder, follow these steps:

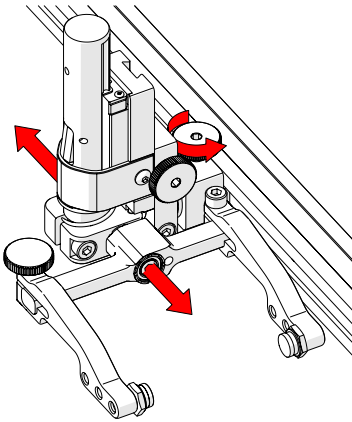

Fig. 105 - Adjust on frame bar

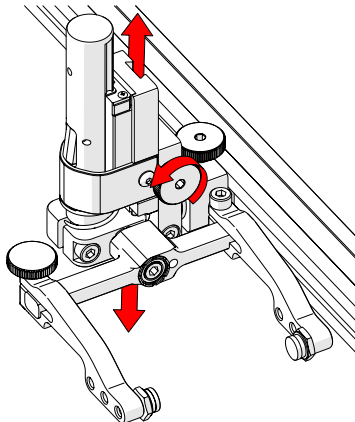

Fig. 106 - Vertical adjustment

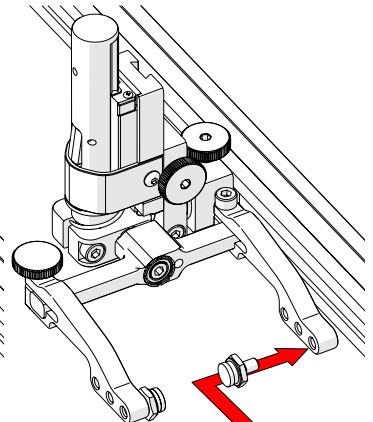

Fig. 107 - Place buttons

1. The probe holder adjustment knob allows the probe holder to be attached to a frame bar, as well as horizontal positioning on a frame bar (Fig. 105).
2. The vertical adjustment knob allows the vertical probe holder height adjustment (Fig. 106).
3. Position the pivot buttons where necessary. When a narrow scanning footprint is required, use the pivot button holes closest to the yoke (Fig. 107).

**TIP:** Probe pivoting may be impeded when closer to the yoke.

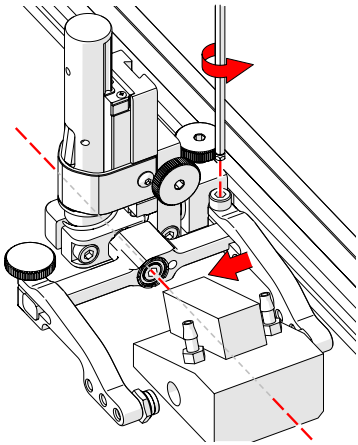

Fig. 108 - Adjust inner arm

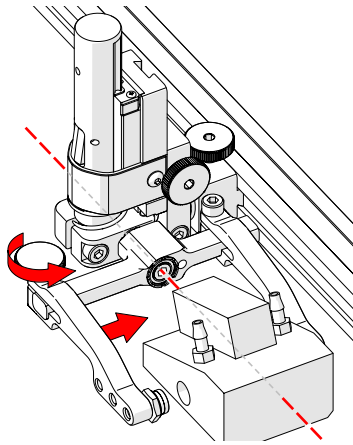

Fig. 109 - Adjust outer arm

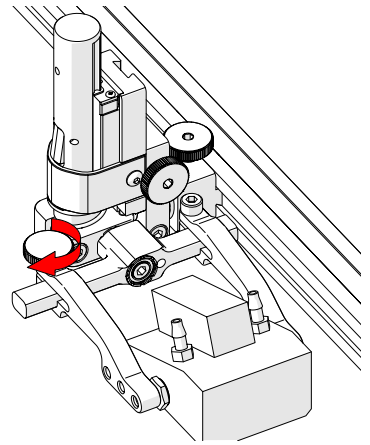

Fig. 110 - Tighten arm knob

4. Position the wedge on the inner probe holder arm (Fig. 108).

**TIP:** The probe holder yoke can accommodate many different probe and wedge sizes of varying widths. It is best to centre the wedge with the yoke's pivot axis. This can reduce wedge 'rocking' when scanning. Position the inner probe holder arm accordingly (Fig. 108) using the supplied 3 mm hex driver (Fig. 51).

5. Loosen the probe holder arm adjustment knob (Fig. 109) and slide the probe holder arm along the yoke pinching the wedge in place.
6. Tighten the probe holder arm adjustment knob (Fig. 110).

### 5.9.2.2 Probe Holder Vertical Adjustment

To adjust the probe holder vertically, follow these steps:

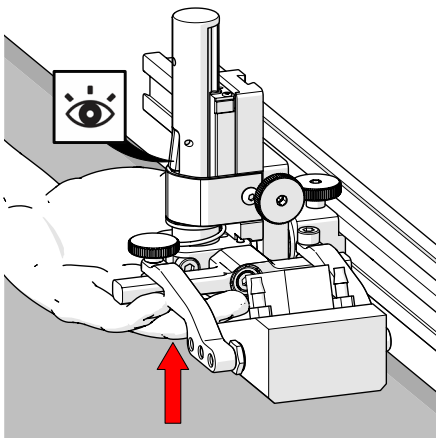

Fig. 111 - Latch probe holder

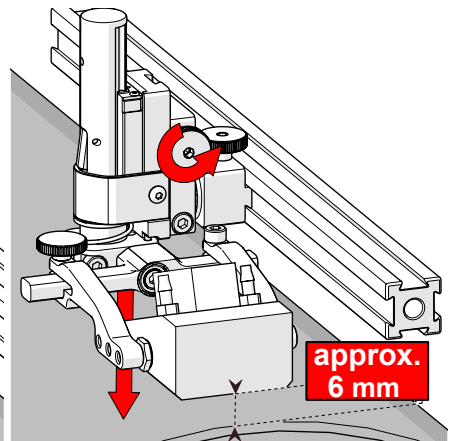

Fig. 112 - Lower toward scan surface

1. Ensure the probe holder is in the latched, upper position. Lift the probe holder until the latch is fully exposed and snaps out to lock (Fig. 111).
2. Loosen the vertical adjustment knob and slide the probe holder down until the wedge is approximately 6 mm ( $\frac{1}{4}$  in) above inspection surface.
3. Tighten the vertical adjustment knob (Fig. 112).

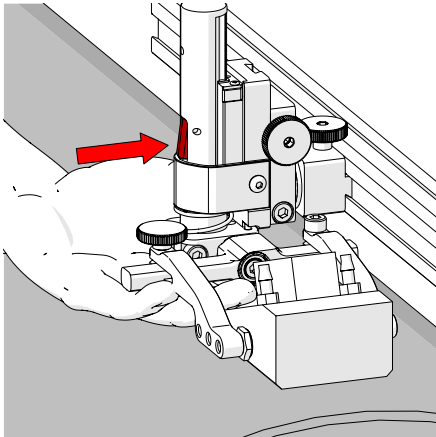

Fig. 113 - Press latch button

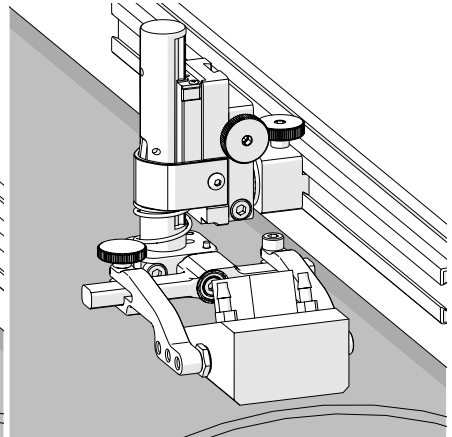

Fig. 114 - Lower toward scan surface

4. Lift the yoke slightly and press the latch button (Fig. 113), then slowly lower towards the scanning surface to apply spring pressure to the wedge (Fig. 114).

**TIP:** If less spring force is desired, refer to step 2 and place the wedge approximately 20 mm ( $\frac{3}{4}$  in) above the inspection surface.

### 5.9.2.3 Probe Holder Transverse Adjustment

To adjust the probe holder's transverse angle, follow these steps:

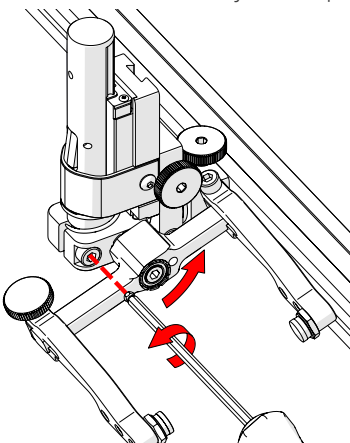

Fig. 115 - Loosen 3 mm screw

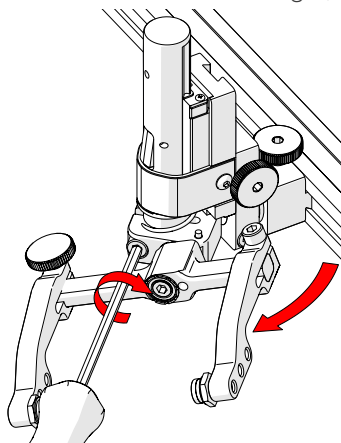

Fig. 116 - Rotate and tighten

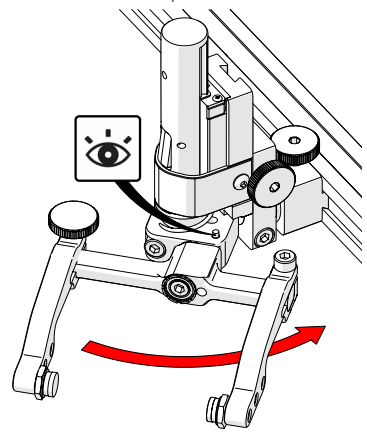

Fig. 117 - Stop post locates 90°

1. Ensure the probe holder is in latched, upper position (*Fig. 111*).
2. Using the supplied 3 mm hex driver loosen the transverse adjustment screw (*Fig. 115*) and rotate the yoke about the vertical shaft achieving the desired angle.
3. Tighten the transverse adjustment screw (*Fig. 116*).

To return the transverse adjustment to neutral ( $90^\circ$ ). The probe holder must be in the latched, upper position (*Fig. 111*). Rotate the yoke until the stop post contacts the base of the probe holder (*Fig. 117*). Then tighten the transverse adjustment screw.

#### 5.9.2.4 Probe Holder Longitudinal Adjustment

To adjust the probe holder's vertical angle for longitudinal scanning, follow these steps:

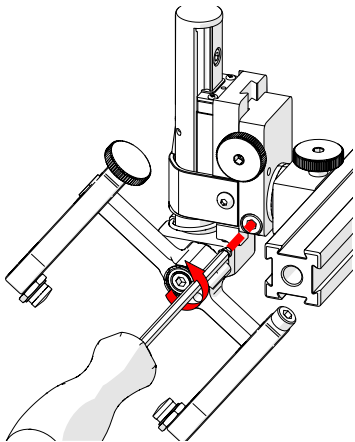

Fig. 118 - Loosen 3 mm screw

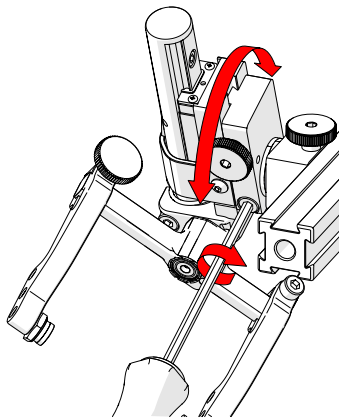

Fig. 119 - Rotate to position

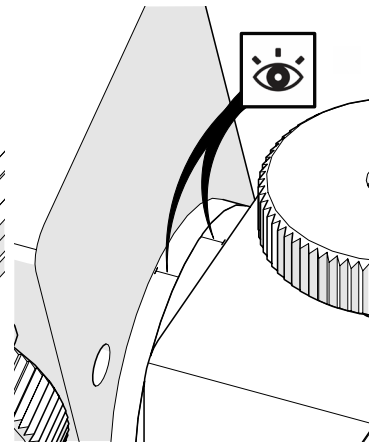

Fig. 120 - Line up markers

1. Ensure the probe holder is in the latched, upper position (*Fig. 111*).
2. Using the supplied 3 mm hex driver (*Fig. 51*), loosen the longitudinal adjustment screw (*Fig. 118*).
3. Rotate the main body of the probe holder until it is at the desired angle (*Fig. 119*).
4. Tighten the longitudinal adjustment screw (*Fig. 119*).

To return the longitudinal adjustment to neutral ( $90^\circ$ ). Line up the longitudinal adjustment indicator markers (*Fig. 120*).



### 5.9.2.5 Probe Holder Left/Right Conversion

To reverse the probe holder, follow these steps:

**NOTE:** The 1.5 mm hex wrench (Fig. 54) is required to perform this operation.

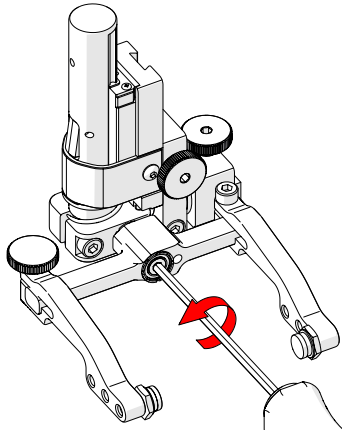

Fig. 121 - Unscrew yoke pivot screw

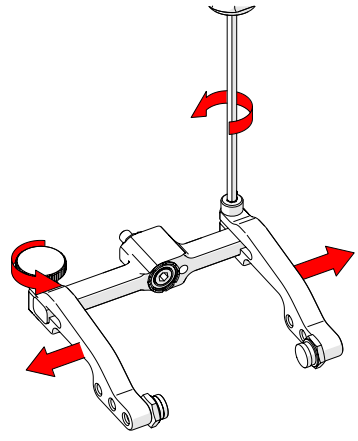

Fig. 122 - Remove probe holder arms

1. Ensure the probe holder is in the latched, upper position (Fig. 111).
2. Using the supplied 3 mm hex driver (Fig. 51), unscrew the yoke pivot screw and remove the yoke (Fig. 121).
3. Loosen the probe holder arm adjustment knob and the arm clamp screw. Slide the probe holder arms off the yoke (Fig. 122).

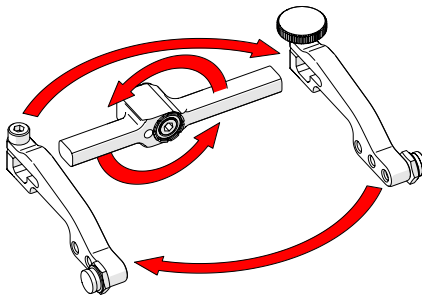

Fig. 123 - Flip yoke and reverse arms

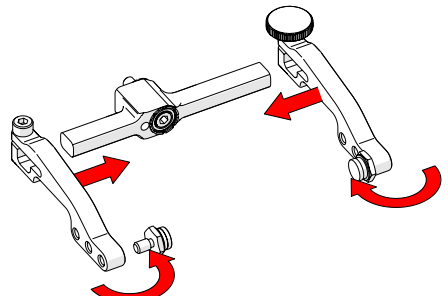

Fig. 124 - Attach arms & move buttons

4. Flip the yoke 180° and reverse the probe holder arms (Fig. 123).
5. Place the pivot buttons on the inside of the probe holder arms (Fig. 124) using a 3/8 in wrench (Fig. 52).

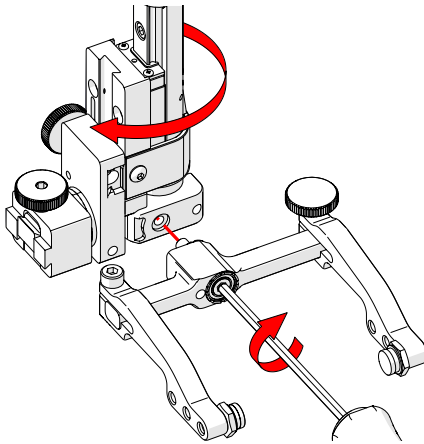

Fig. 125 - Screw yoke to opposite side

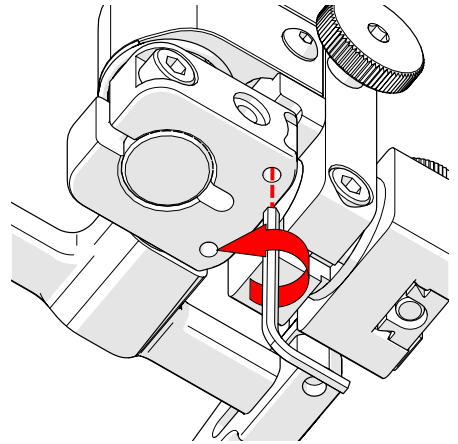

Fig. 126 - Lower 90° stop post

6. Mount the yoke to the opposite side of the base using the supplied 3 mm hex driver (Fig. 125).

**TIP:** Keep the yoke level with the base to ensure no conflicts with the plunger/set screw attached to the yoke.

7. Locate the recessed M3 screw on the bottom of the probe holder. Unscrew the stop post using a 1.5 mm hex wrench (Fig. 54) until it has cleared all obstructions. Do not remove the stop post (Fig. 126).

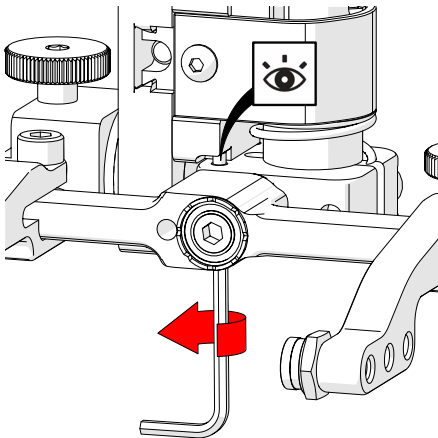

Fig. 127 - Raise opposite 90° stop post

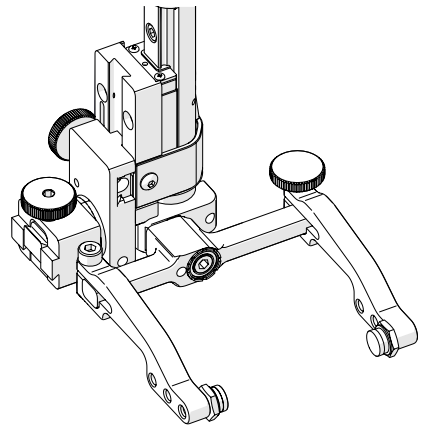
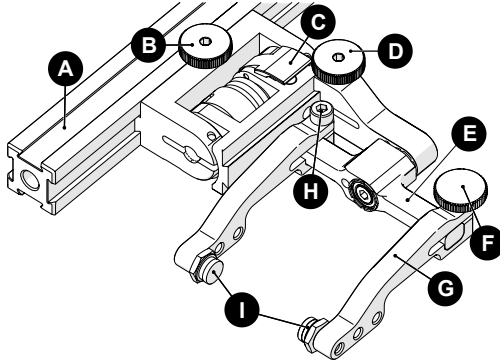

Fig. 128 - Reversed probe holder

8. Raise the stop post on the opposite side until the side of the post contacts the 90° stop point on the probe holder's base (Fig. 127).

### 5.9.3. Slip Joint Probe Holder



A	Frame Bar
B	Probe Holder Adjustment Knob
C	Latch
D	Swing Arm Knob
E	Yoke
F	Probe Holder Arm Adjustment Knob
G	Probe Holder Arm
H	Arm Clamp Screw
I	Pivot Buttons

Fig. 129 - Slip Joint Probe Holder

#### 5.9.3.1 Probe Holder Setup

To mount a UT wedge in the probe holder, follow these steps:

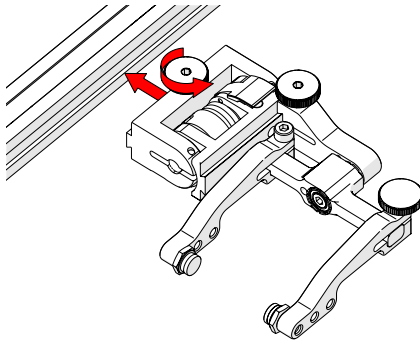

Fig. 130 - Attach to frame bar

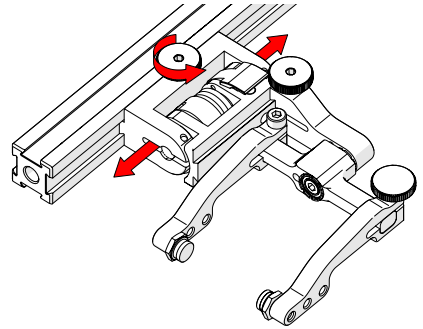

Fig. 131 - Adjust on frame bar

1. Rotate the probe holder adjustment knob and attach the probe holder to a frame bar (Fig. 130).
2. Use the probe holder adjustment knob to position the probe holder along the frame bar (Fig. 131).

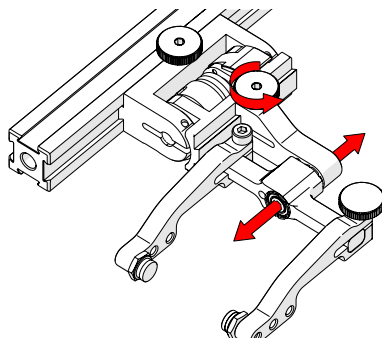

Fig. 132 - Adjust swing arm

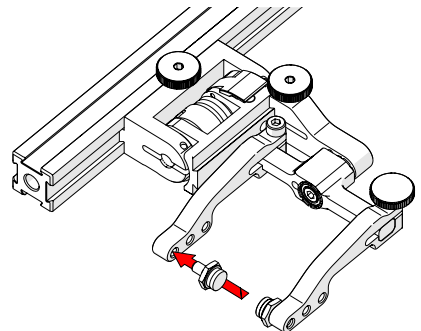

Fig. 133 - Place pivot buttons

3. Use the swing arm knob to position the swing arm (Fig. 132).

**TIP:** The swing arm is typically used to adjust TOFD centre to centre distance relative to the phased array probes on a four probe configuration.

4. Using the supplied 3/8 in wrench, place the pivot buttons (Fig. 133) farthest from the yoke for maximum wedge clearance.

**TIP:** If narrow scanning footprint is required, use pivot button holes closest to the yoke. Wedge pivoting may be impeded when closer to the yoke.

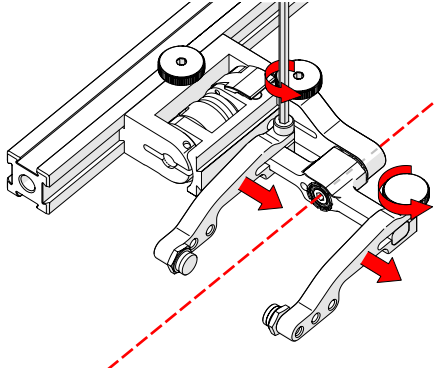

Fig. 134 - Adjust probe holder arms

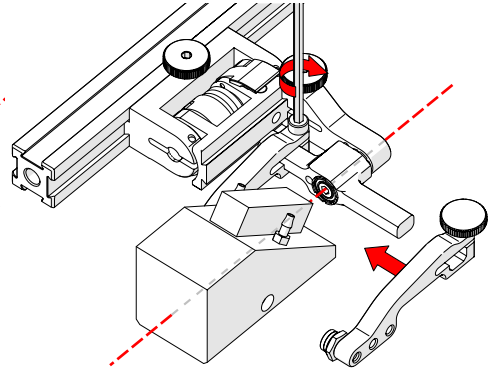

Fig. 135 - Place wedge

5. Loosen the probe holder arm adjustment knob (Fig. 134) and remove the outer probe holder arm from yoke.
6. Adjust the inner probe holder arm as required to best centre the probe on the yoke's pivot axis (Fig. 134).

**TIP:** The probe holder yoke can accommodate different probe and wedge sizes of varying widths. It is best to centre the wedge with the yoke's pivot axis to reduce wedge tipping when scanning. Position the inner probe holder arm accordingly with the centre of the yoke (Fig. 134).

7. Position the wedge on the inner probe holder arm (Fig. 135).
8. Slide the outer probe holder arm along the yoke pinching the wedge in place.
9. Tighten the probe holder arm adjustment knob (Fig. 136).

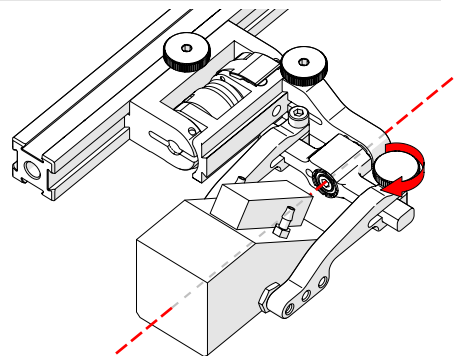

Fig. 136 - Pinch wedge with arm

### 5.9.3.2 Probe Holder Adjustment

To adjust the probe holder, follow these steps:

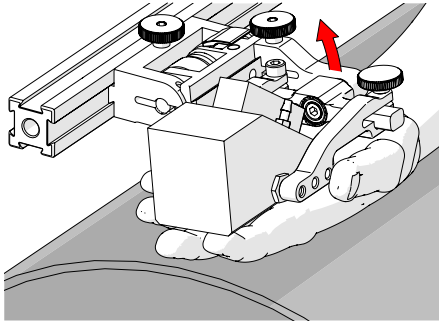

Fig. 137 - Lift to latched position

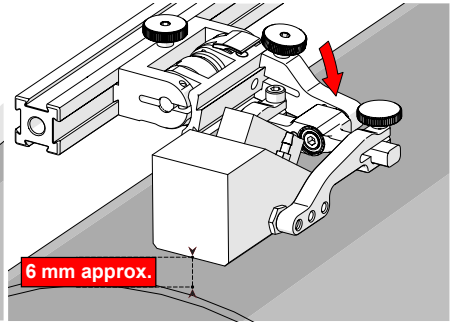

Fig. 138 - Lower to scanning surface

1. Ensure the probe holder is in the latched, upper position (Fig. 137). If the probe holder is already latched, it will only move within the slip joint adjustment range and have no spring tension.
2. Push the probe holder yoke down toward the inspection surface until the wedge is approximately 6 mm ( $\frac{1}{4}$  in) above the inspection surface (Fig. 138).

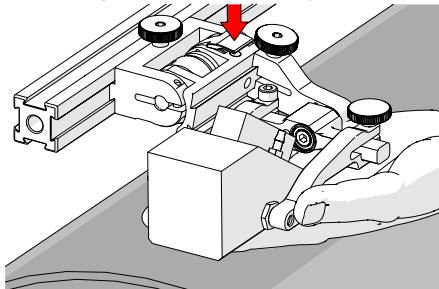

Fig. 139 - Lift and press latch button

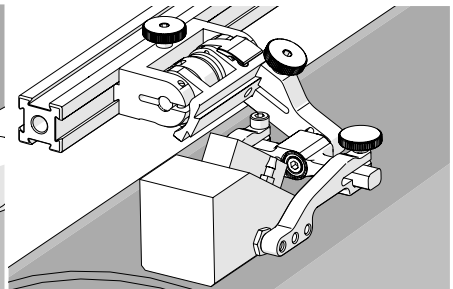

Fig. 140 - Spring loaded scan position

3. Lift the probe slightly and press the latch button (Fig. 139) to apply spring pressure to the wedge.
4. Gently lower probe holder and wedge to the scanning surface (Fig. 140).

### 5.9.3.3 Probe Holder Force Adjustment

It is possible to adjust the tension of the probe holder spring.

**NOTE:** To perform this operation, the 2 mm hex wrench (Fig. 55) and 3 mm hex wrench (Fig. 51) are required.

Light	1 kg	2 lb
Medium	2 kg	4 lb
Heavy	3 kg	6 lb

When configured correctly, these settings exert the indicated spring force on the Probe.

To adjust the probe holder's force, follow these steps:

**NOTE:** Do not perform this operation on the scanning surface.

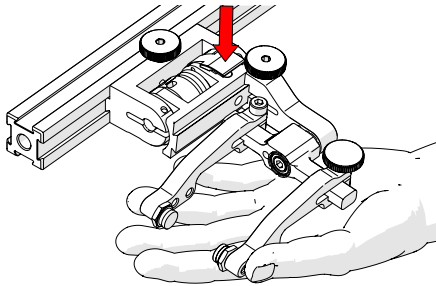

Fig. 141 - Lift slightly and press Latch

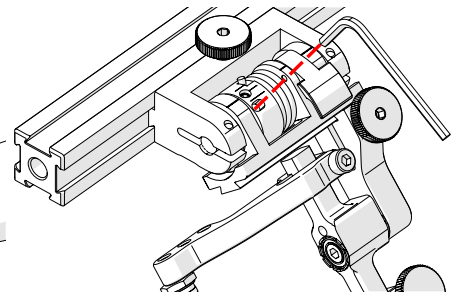

Fig. 142 - Unlatched position

1. Ensure the probe holder is in the upright latched position (Fig. 137).
2. Lift the probe holder slightly and press the latch button (Fig. 141) to release the probe holder the full 45° degrees.
3. Insert the short arm of a 3 mm hex wrench into the 3 mm slot (Fig. 142).

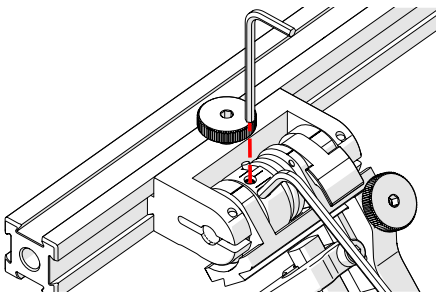

Fig. 143 - Insert hex tools

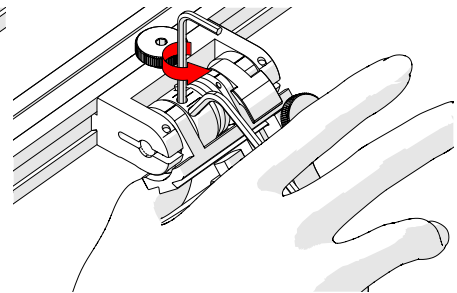

Fig. 144 - Press 3 mm hex wrench down

4. Place the 2 mm hex wrench into the force adjustment screw (Fig. 143).
5. Lightly press the long arm of the 3 mm hex wrench down. Using the 2 mm hex wrench, loosen the force adjustment screw but do not remove it (Fig. 144).
6. Gently apply pressure on the long leg of the 3 mm hex wrench until the force adjustment marker lines up with the desired spring tension. While keeping the markers in line, tighten the force adjustment screw.

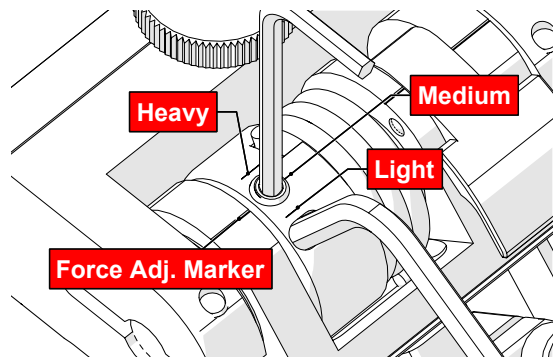

Fig. 145 - Choose desired tension

### 5.9.3.4 Slip Joint Probe Holder Left/Right Conversion

To reverse the probe holder, follow these steps:

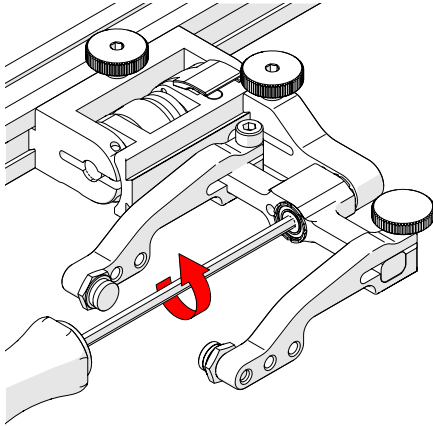

Fig. 146 - Unscrew yoke pivot screw

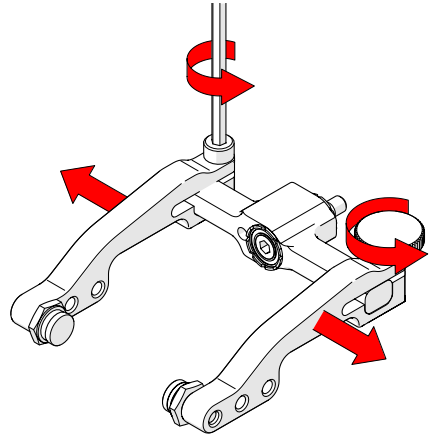

Fig. 147 - Remove arms

1. Unscrew the yoke from the swing arm (*Fig. 146*).
2. Loosen the probe holder arm adjustment knob and arm clamp screw. Slide the arms from the yoke (*Fig. 147*).

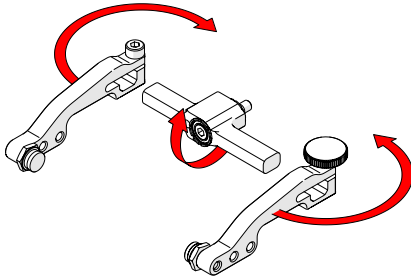

Fig. 148 - Flip yoke and reverse arms

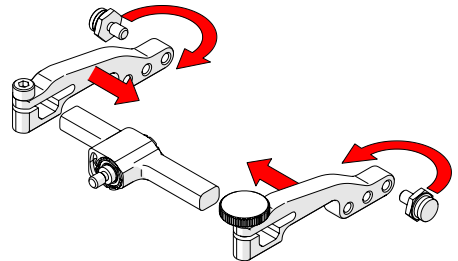

Fig. 149 - Attach arms and move buttons

3. Flip the yoke 180° and reverse the probe holder arms (*Fig. 148*).
4. Place the pivot buttons on the inside of the probe holder arms (*Fig. 149*) using a 3/8 in wrench (*Fig. 52*). Slide the arms onto the yoke and tighten the probe holder arm adjustment knob and the arm clamp screw.

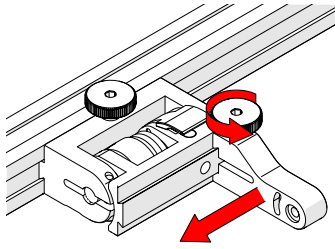

Fig. 150 - Position swing arm

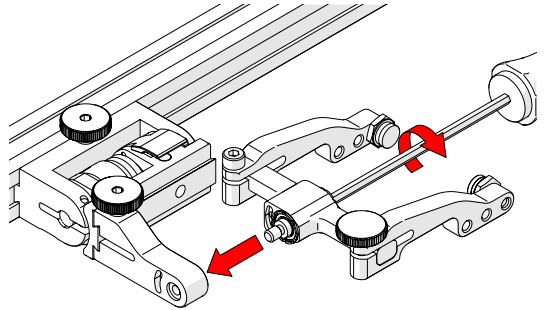

Fig. 151 - Install yoke to swing arm

5. Loosen the swing arm knob and slide the swing arm to the opposite end of the probe holder bracket (*Fig. 150*) or preferred position. Tighten the swing arm knob.
6. Using the 3 mm hex driver, screw the yoke pivot screw into the opposite side of the probe holder swing arm (*Fig. 151*). Ensure the yoke is level to avoid issues with the plunger/set screw.

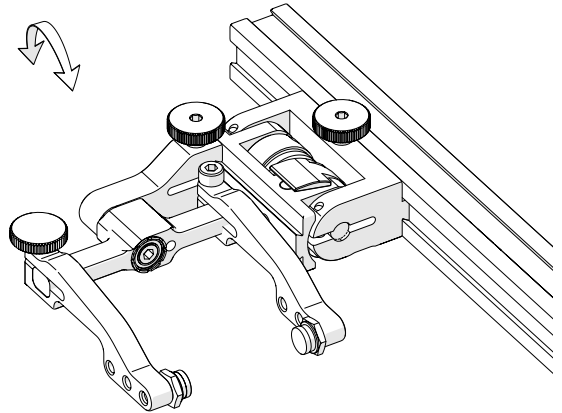

Fig. 152 - Reversed probe holder



## 5.10. Probe Holder Frames

### 5.10.1. Low Profile Probe Holder Frame - Flat or Circumferential Only



#### **WARNING! FALLING OBJECT HAZARD.**

It is imperative that the steps below be followed to properly set the height of the probe holder frame. If the height of the probe holder frame is set too low, the crawler may fall and **SEVERE INJURY** or **DEATH** could result.

The low profile frame adds weld scanning capability to the **SKOOT** motorized scanner. This frame can utilize (4) slip joint probe holders (2 Phased Array and 2 TOFD, typically). The low profile design of this frame allows for scanning on diameters where radial clearance is limited.

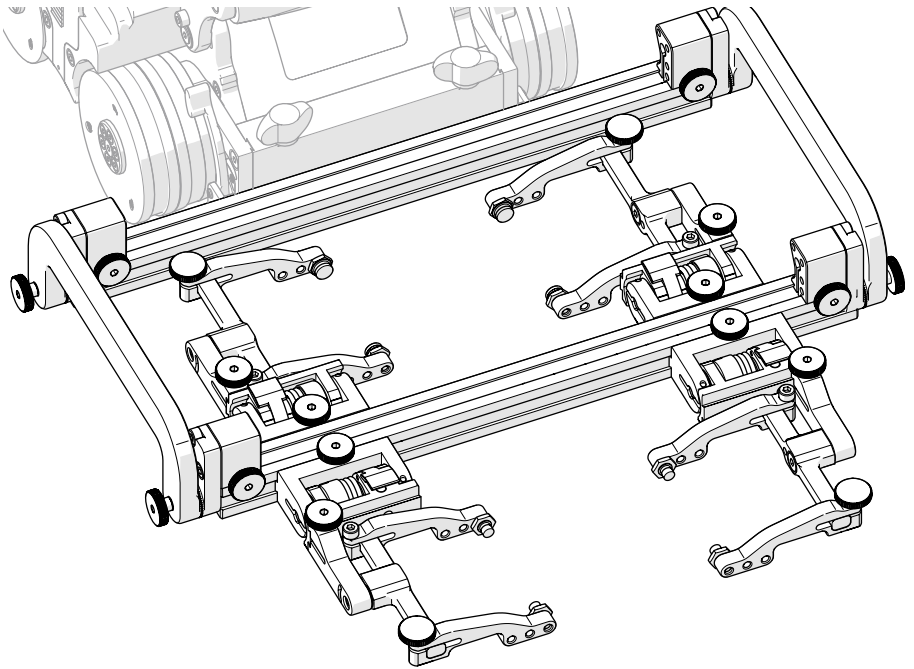

Fig. 153 - Low profile probe holder frame

1. Attach the wedges to the probe holders that are to be used (see *Probe Holder Setup* on page 64 for additional details).

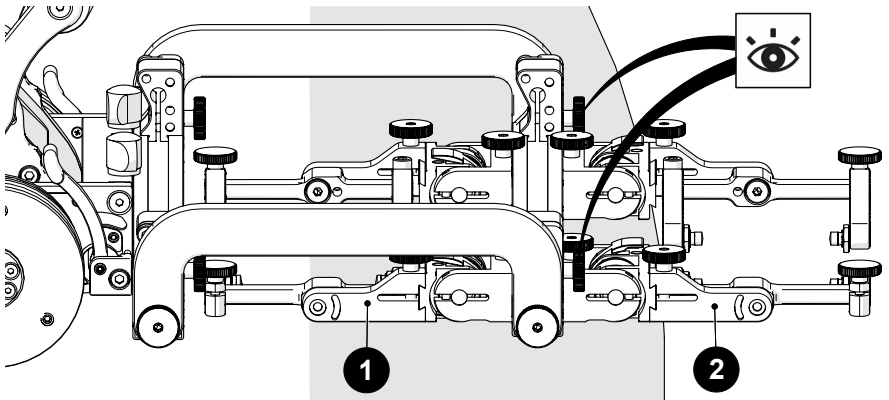

Fig. 154 - Position primary and secondary probe holders

2. Affix the probe holders (with attached wedges) to the low profile probe holder frame. On the frame bar, place the secondary probe holders at the front (Fig. 154-2) and the primary probe holders at the rear (Fig. 154-1).

**TIP:** Due to their larger size, scan results are generally improved when pulling or dragging phased array wedges.

3. Mount the low profile probe holder frame to the crawler (see “Cable Retainer” on page 48). When mounting the low profile frame, ensure the attachment knobs (Fig. 154) are at the front (non-crawler side).

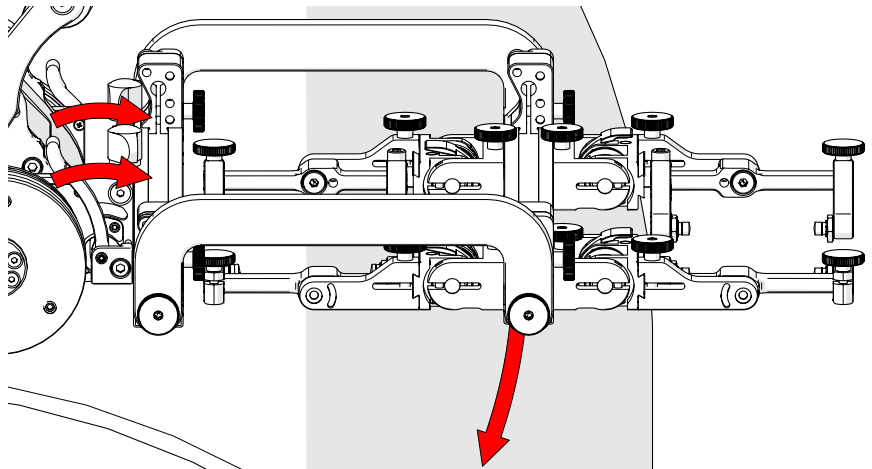

Fig. 155 - Align swivel mount with scan surface

4. Release the two swivel mount levers (Fig. 155) to position the swivel mount parallel to the scan surface (Fig. 156). Lock the crawler swivel mount levers when aligned with the scan surface.

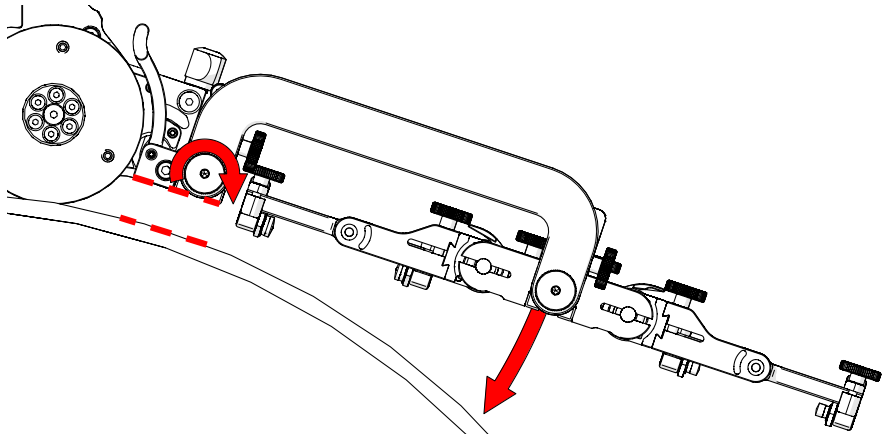

Fig. 156 - Set rear rotational adjustment knob

5. Loosen the rear rotational adjustment knob to lower the front frame bar of the low profile frame towards the inspection surface (Fig. 156).

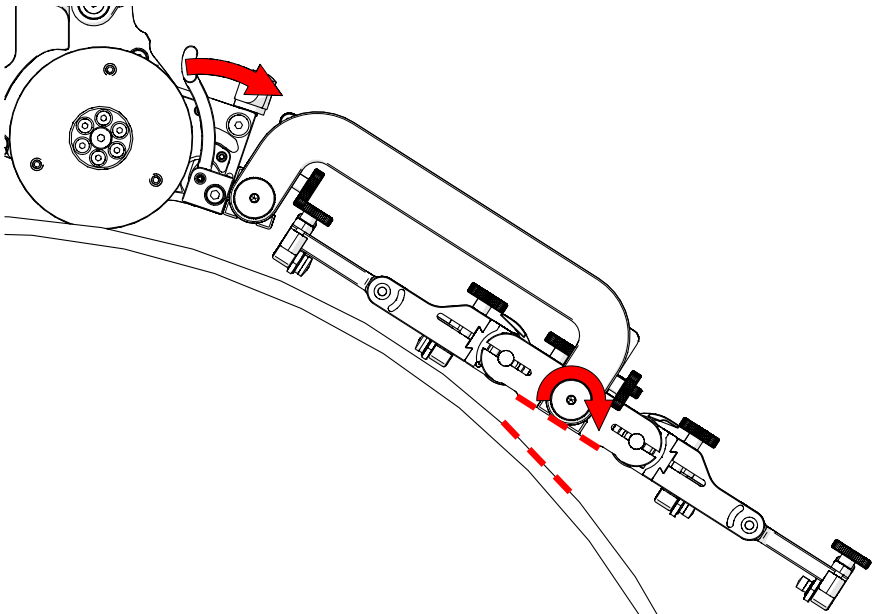
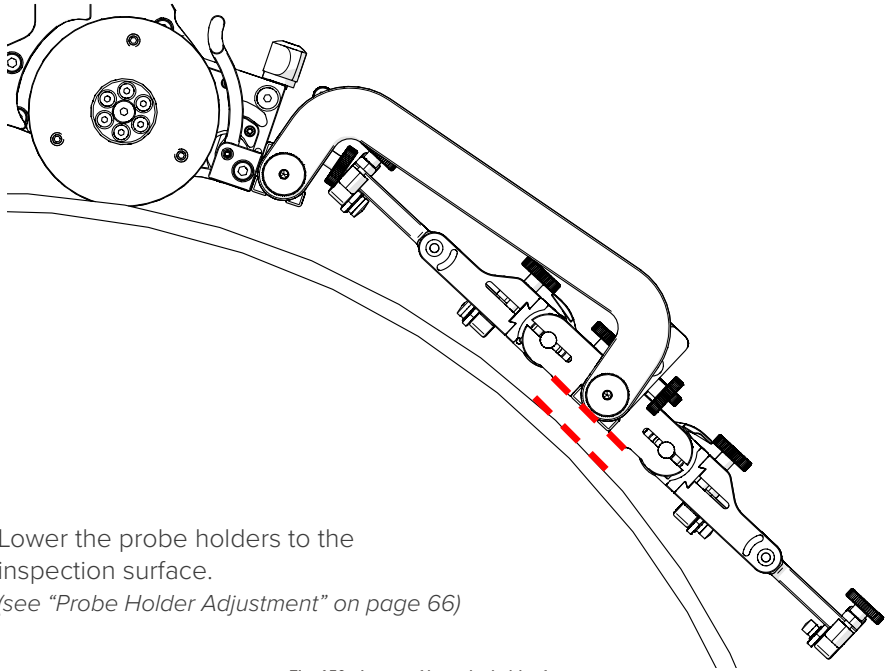

Fig. 157 - Align probe holder tangent with scan surface

6. Loosen the front rotational adjustment knob (Fig. 157) to align the frame bar parallel with the scan surface (Fig. 158).



7. Lower the probe holders to the inspection surface.  
(see *"Probe Holder Adjustment"* on page 66)

Fig. 158 - Low profile probe holder frame

## 5.10.2. Vertical Probe Holder Frame - Flat or Circumferential Only



### **WARNING! FALLING OBJECT HAZARD.**

It is imperative that the steps below be followed to properly set the height of the probe holder frame. If the height of the probe holder frame is set too low, the crawler may fall and **SEVERE INJURY** or **DEATH** could result.

The vertical probe holder frame adds weld scanning capability to the **SKOOT** motorized scanner. This frame uses (4) vertical probe holders. Additional frame components allow up to six probes to be used (*contact Jireh Industries Ltd. on page 1*).

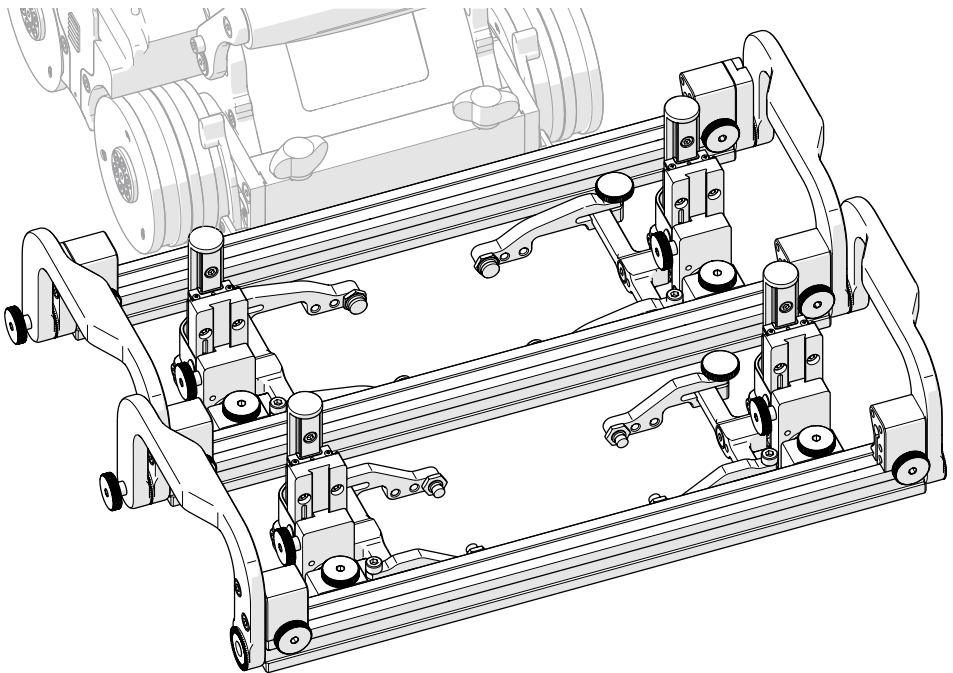

Fig. 159 - Vertical probe holder frame

1. Attach the wedges to the probe holders that will be used (*see Probe Holder Setup on page 58 for additional details*).

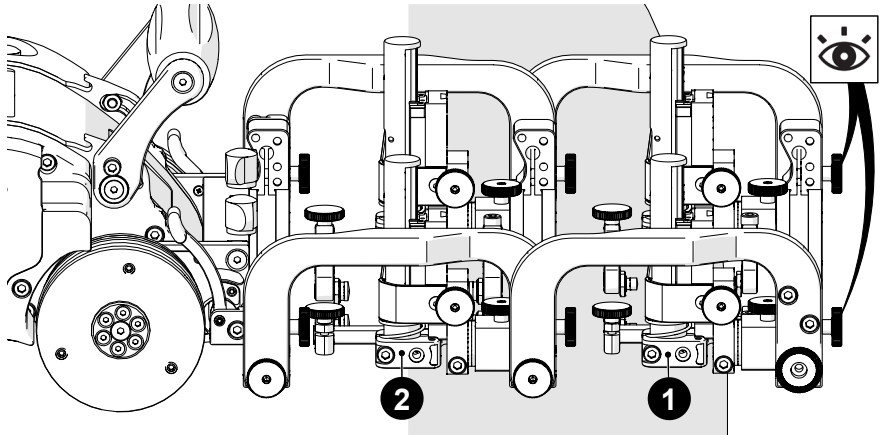

Fig. 160 - Position primary and secondary probe holders

2. Affix the probe holders (*with attached wedges*) to the probe holder frame. Place the secondary probe holder at the front of the frame (*Fig. 160-1*) and place the primary probe holders at the rear of the frame bar (*Fig. 160-2*).

**TIP:** Due to their larger size, scan results are generally improved when pulling or dragging phased array wedges.

3. Mount the probe holder frame to the crawler (*see Cable Retainer on page 48 for additional details*). When mounting the probe holder frame, ensure the attachment knobs (*Fig. 161*) are at the front (*non-crawler side*).

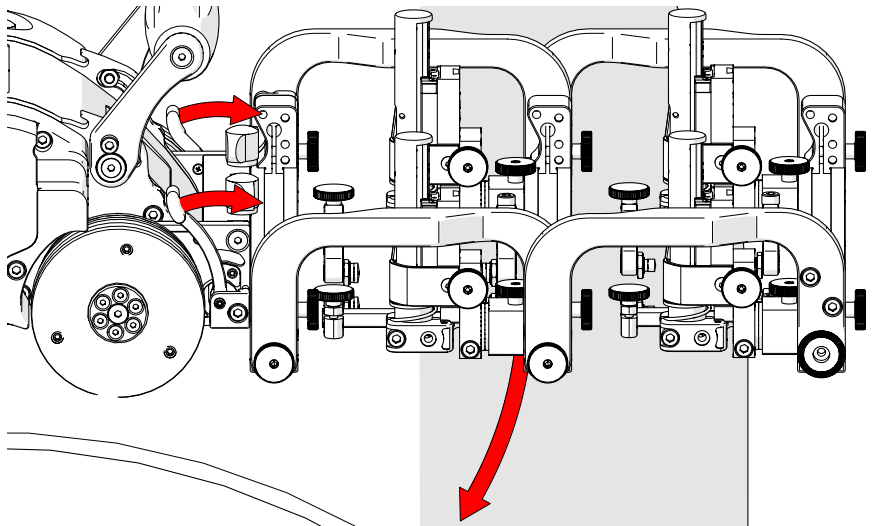

Fig. 161 - Align swivel mount with scan surface

4. Release the two swivel mount levers (Fig. 161) to position the swivel mount parallel to the scan surface (Fig. 162). When alignment with the scan surface is achieved, lock the crawler swivel mount levers.

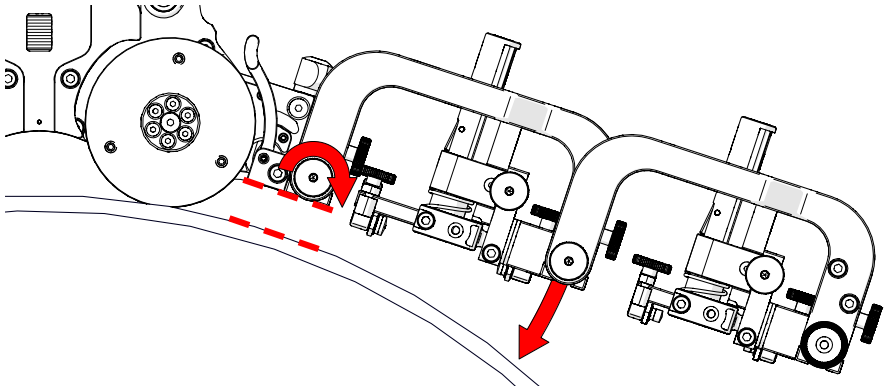

Fig. 162 - Set rear rotational adjustment knob

5. Loosen the rear rotational adjustment knob to lower the weld scan frame towards the inspection surface (Fig. 162).

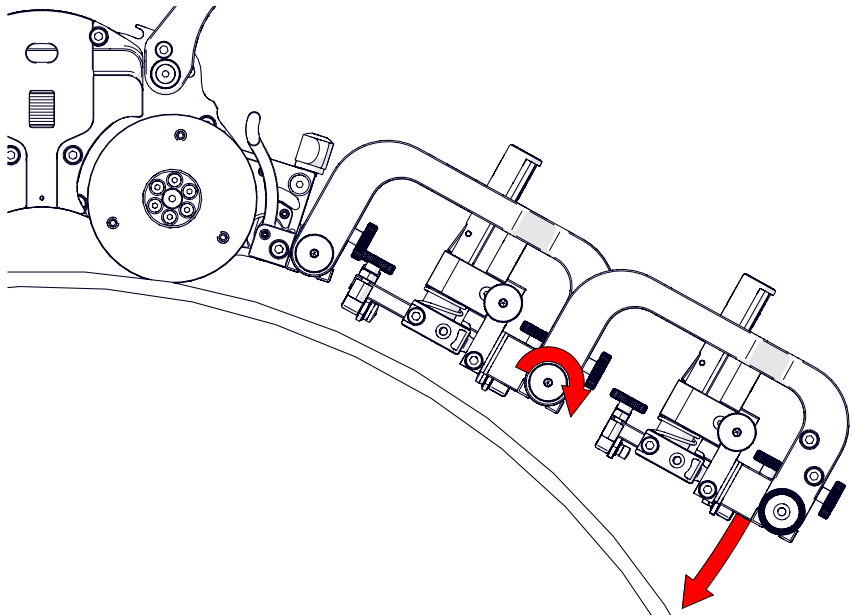

Fig. 163 - Set front rotational adjustment knob

6. Loosen the front rotational adjustment knob (Fig. 163) to align the TOFD probe holders parallel with the scan surface (Fig. 164).

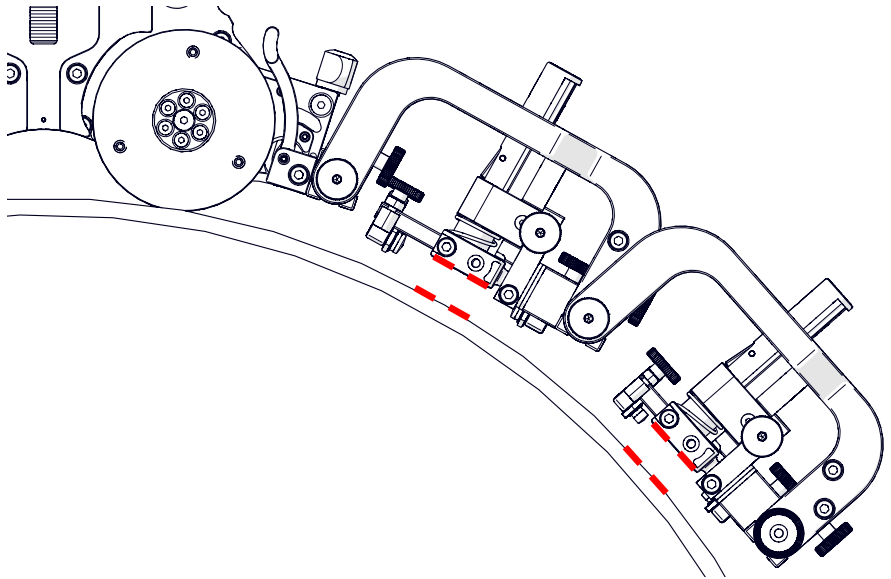

Fig. 164 - Align probes with the scan surface tangent



### 5.10.3. Pivoting Probe Holder Frame



#### **WARNING! FALLING OBJECT HAZARD.**

It is imperative that the steps below be followed to properly set the height of the probe holder frame. If the height of the probe holder frame is set too low, the crawler may fall and **SEVERE INJURY** or **DEATH** could result.

The pivoting probe holder frame utilizes vertical probe holders. The **SKOOT** can guide as many as six probes in the longitudinal direction.

**NOTE:** A minimum OD of 762 mm (30 in) is required for longitudinal scanning.

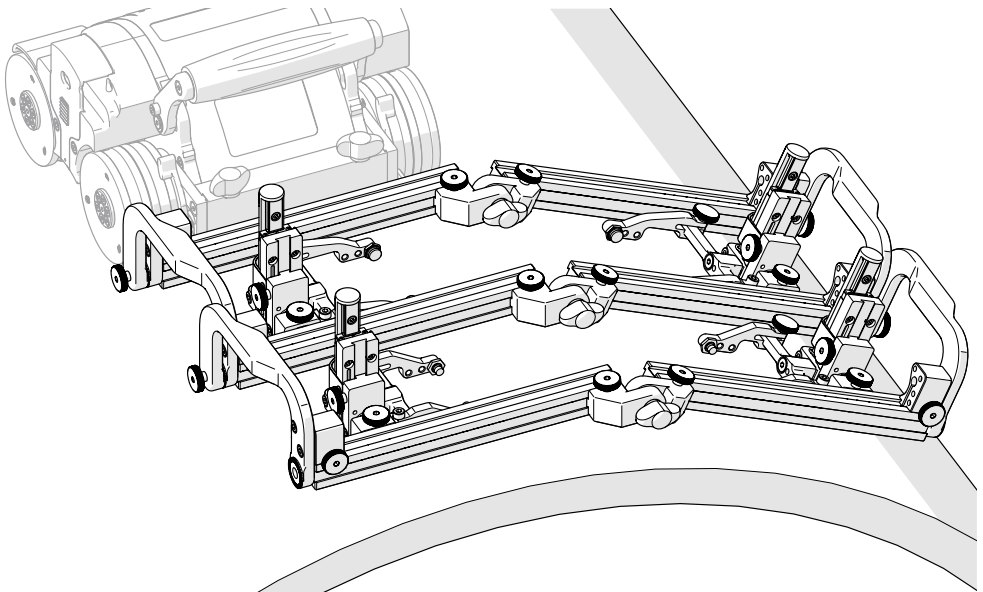

Fig. 165 - Pivoting Probe Holder Frame

### 5.10.3.1 Mounting a Pivoting Probe Holder Frame

1. If attached, use the 3 mm hex driver to remove the probe holder pivot mount from the pivoting probe holder frame.
2. Attach the wedges that are to be used with the probe holders (see *Probe Holder Setup on page 58 for additional details*).

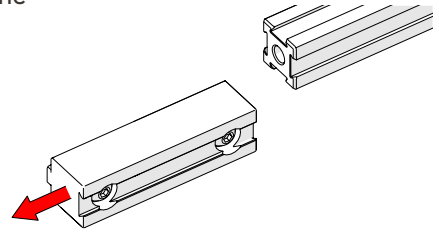

Fig. 166 - Remove probe holder pivot mount

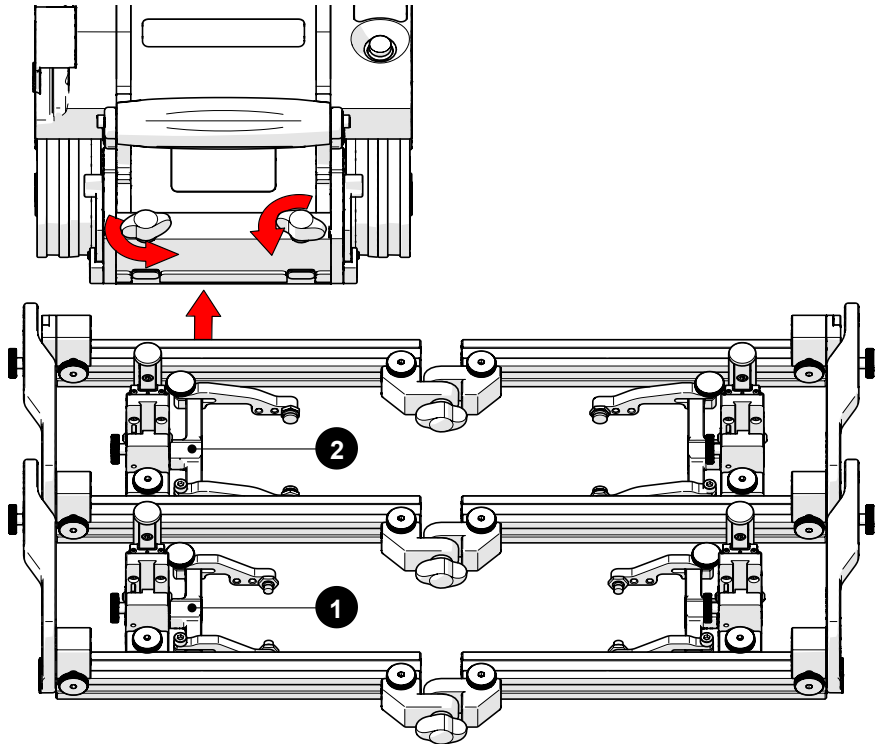

Fig. 167 - Connect frame to crawler's swivel mount

3. Affix the probe holders (*with attached wedges*) to the probe holder frame. Place the secondary probe holders at the front of the frame (Fig. 167-1) while placing the primary probe holders at the rear of the frame system (Fig. 167-2).

**TIP:** Phased array wedges are designed to be pulled along a scan surface.

4. Mount the pivoting probe holder frame to the crawler (see *Crawler on page 45 for additional details*).

## 5.10.4. Pivoting Probe Holder Frame Setup - Longitudinal Scanning

### 5.10.4.1 Longitudinal Scanning

To prepare the pivoting probe holder frame for longitudinal scanning, follow these steps:

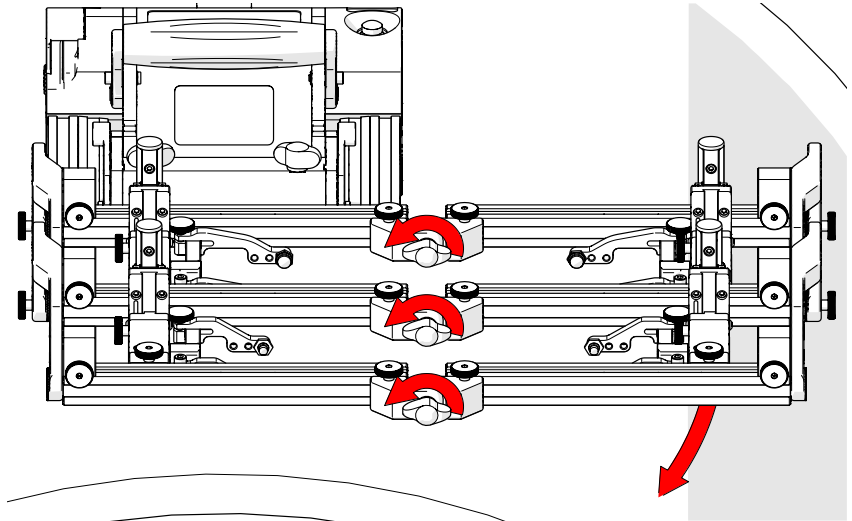

Fig. 168 - Loosen pivot wing knobs

**NOTE:** The swivel mount must be in a horizontal position during longitudinal scanning (see “Crawler” on page 45).

1. Loosen the pivot wing knobs at the centre of the frame system (Fig. 168). Lower the left side of the frame system to align with the tangent of the scan surface. Tighten the pivot wing knobs.

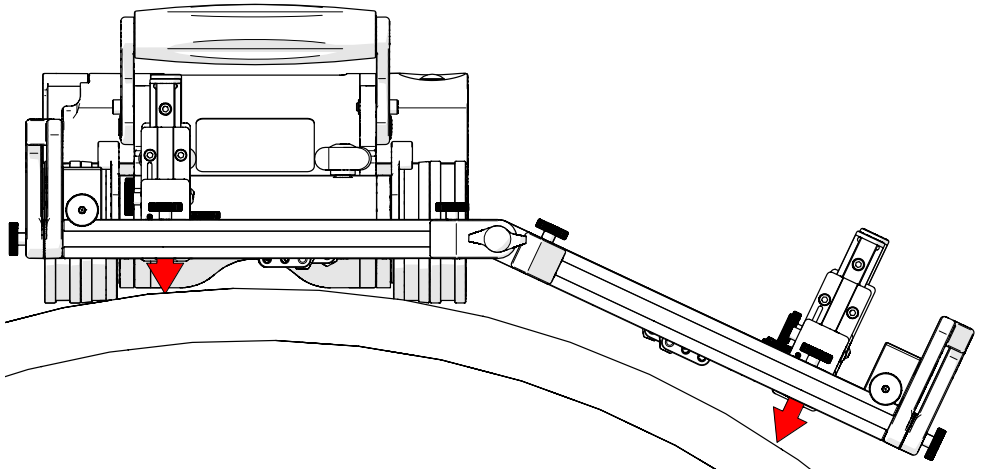

Fig. 169 - Tighten pivot wing knobs

2. Lower the vertical probe holders (see “Probe Holder Vertical Adjustment” on page 59).

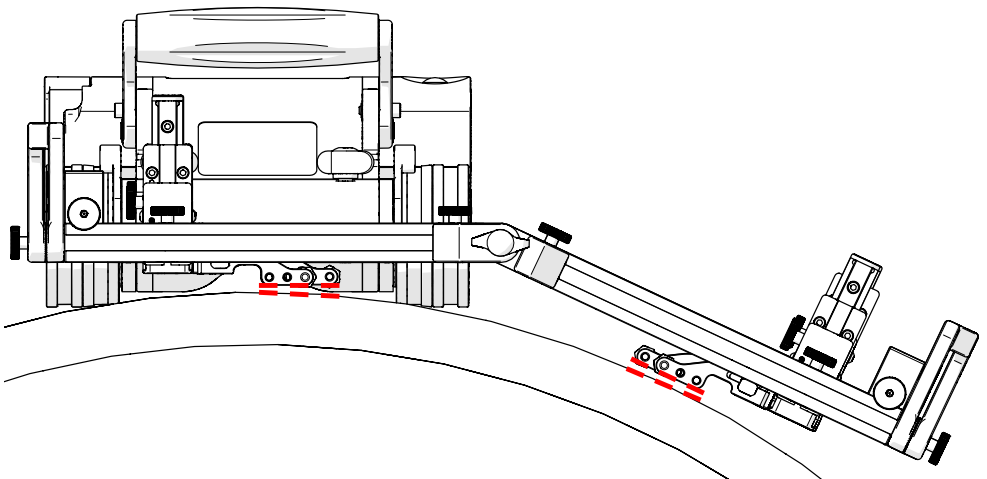

Fig. 170 - Correct probe holder longitudinal adjustment

3. Ensure probe holder arms are parallel to the scan surface (see “Probe Holder Longitudinal Adjustment” on page 61).

#### 5.10.4.2 Circumferential Scanning

(see *Vertical Probe Holder Frame - Flat or Circumferential Only* on page 74 for additional details)

### 5.10.4.3 Pivoting Probe Holder Frame - Flange Scanning

**NOTE:** The optical guide pivot mount is incompatible with the following configuration.

The pivoting probe holder frame may be configured to allow scanning of flanges and the like. The following steps explain the setup of this configuration:

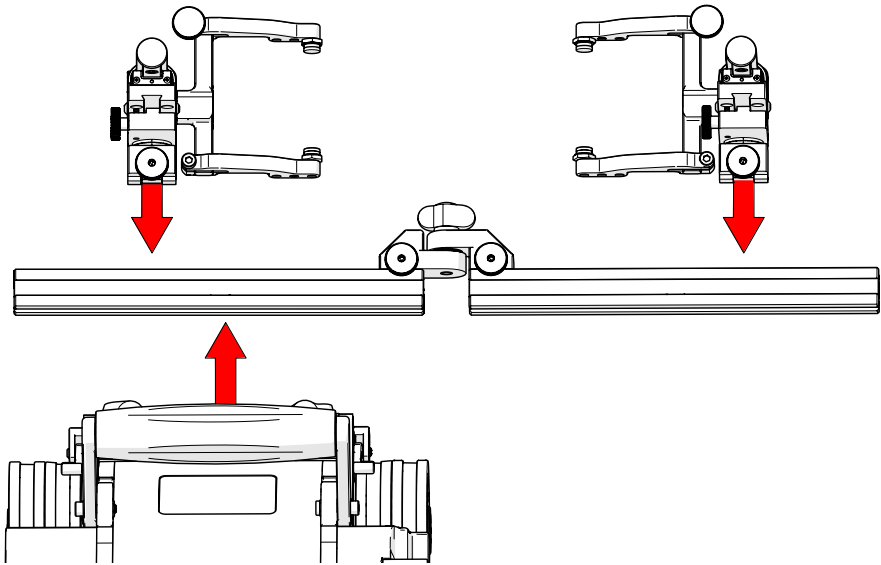

Fig. 171 - Configure assembly and mount to SK00T

1. Disassemble the pivoting probe holder frame to achieve the setup shown (Fig. 171). Ensure proper placement of the frame bar with attached mounting point in relation to the **SK00T**.

**TIP:** When the scanning surface is circumferential, only one frame bar with two probes can be used.

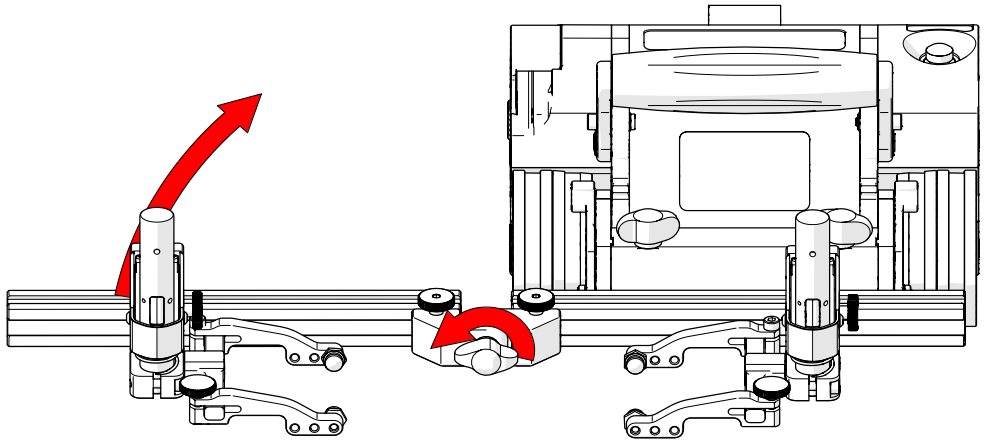

Fig. 172 - Lift frame bar to avoid interference

2. Loosen the pivot wing knob and raise the frame bar to an angle greater than the surface to be scanned (Fig. 172). Tighten the pivot wing knob and place the crawler on the scan surface (see "Placement of Crawler on Inspection Surface" on page 93)
3. Release the front swivel mount adjustment levers to align the swivel mount parallel to the scan surface (Fig. 173).

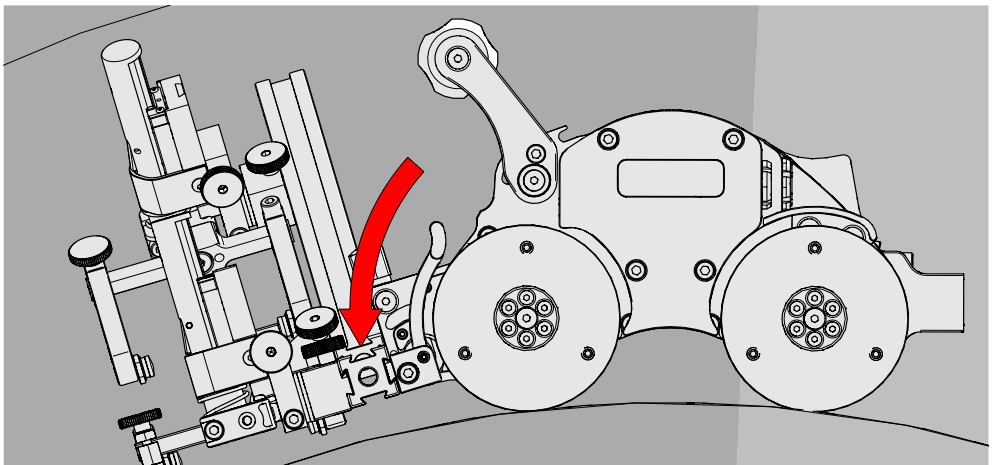

Fig. 173 - Align swivel mount with scan surface

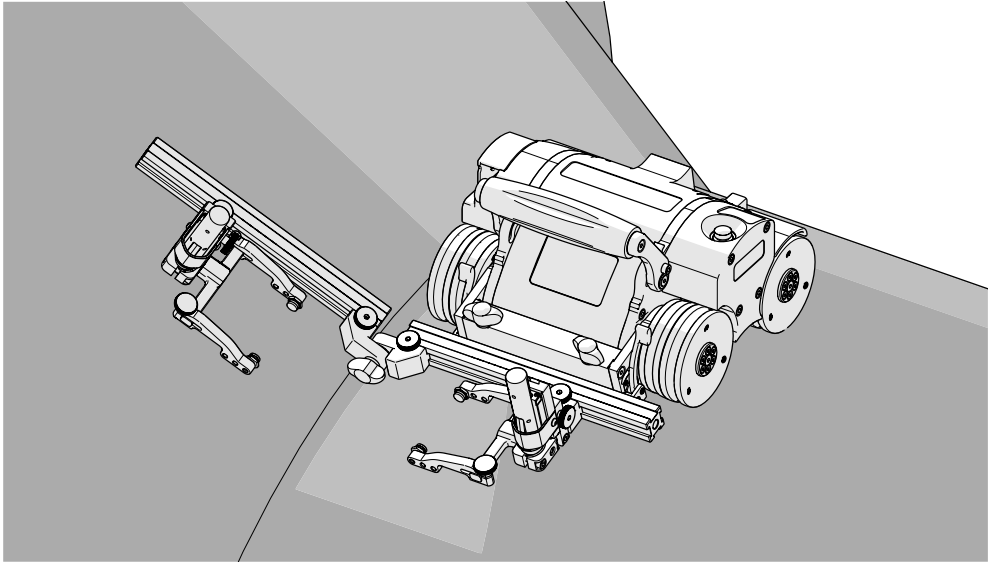

Fig. 174 - Align frame bar with flange scan surface

4. Loosen the pivot wing knob and align the frame bar parallel with the scan surface (*Fig. 174*).

## 5.10.5. Optical Guide Pivot Mount

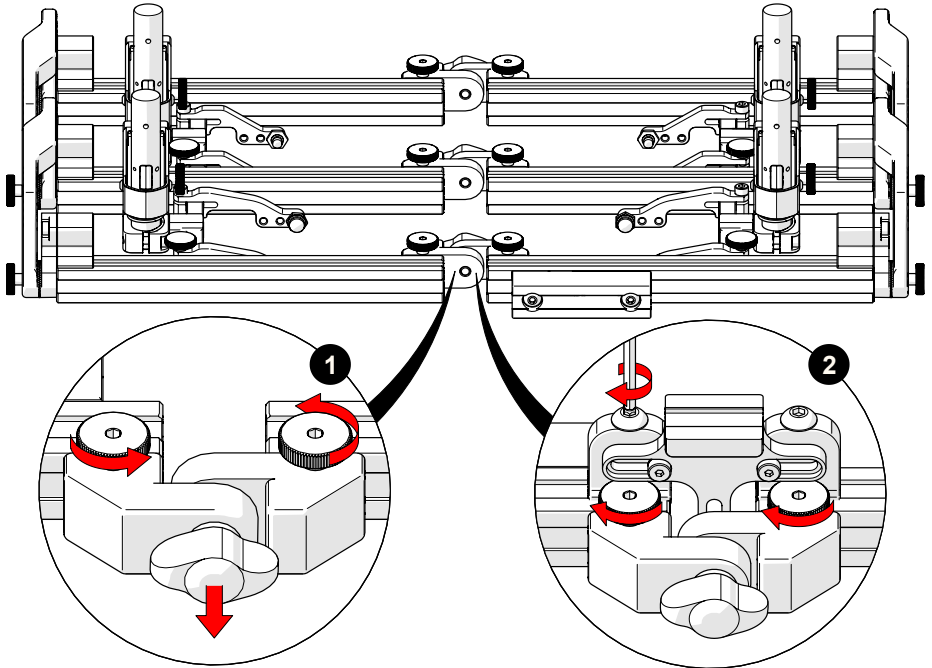

Fig. 175 - Optical guide pivot mount installation

An optional mounting point for any optical guide is available.

- ▶ (see “Battery Powered Optical Guide” on page 86)
- ▶ (see “Optical Guide” user manual)

To install the pivot mount, see the following instructions:

1. Remove the dovetail bar pivot from one of the sets of frame bars (Fig. 175-1). The choice of which dovetail bar pivot to remove is at the user’s discretion.
2. Attach the optical guide pivot mount to the frame bars (Fig. 175-2) and tighten the dovetail knobs and the dovetail screws. Ensure a flush alignment of the pivot mount and the frame bars to achieve proper centring of the optical guide pivot mount.



## 5.11. Accessories

### 5.11.1. Battery Powered Optical Guide



**WARNING! LASER RADIATION.** The battery powered optical guide contains a Class 1M laser. Do not view directly with optical instruments.

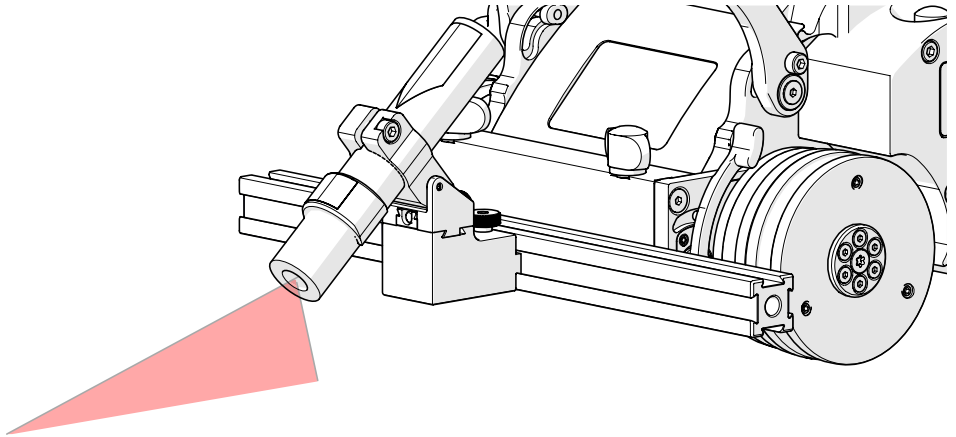

Fig. 176 - Battery powered optical guide

The battery powered optical guide provides a reference point useful for aligning the **SKOOT** to a given path (*i.e. a weld*).

1. Loosen the battery powered optical guide knob and mount the guide to the frame bar (*Fig. 177*).
2. Tighten the battery powered optical guide knob.
3. Adjust the guide's friction pivot to aim the guide as required (*Fig. 178*).
4. Loosen the guide knob to adjust the side-to-side position as required.
5. The included perpendicular mount allows for alternate mounting positions when required.

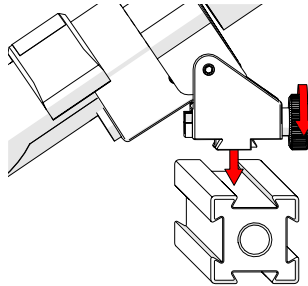

Fig. 177 - Mount on frame bar

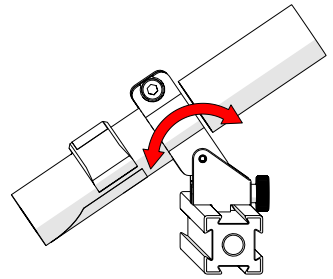

Fig. 178 - Aim guide

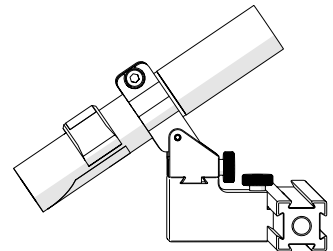

Fig. 179 - Perpendicular mount

**NOTE:** The battery powered optical guide requires 1 AA battery for operation.

## 5.11.2. Cable Management

The cable management is offered in a variety of lengths and provides a means of bundling and protecting cables and hoses that connect to the scanner.

### 5.11.2.1 Mounting the Cable Management

To attach cable management with threaded mount, follow these steps:

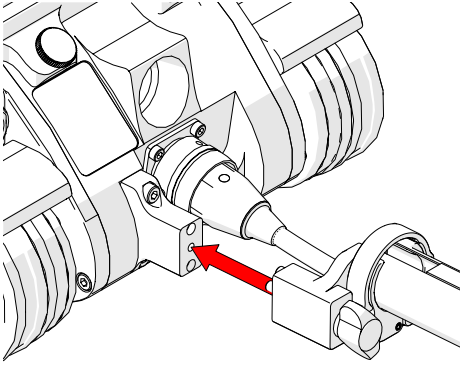

Fig. 180 - Align with umbilical

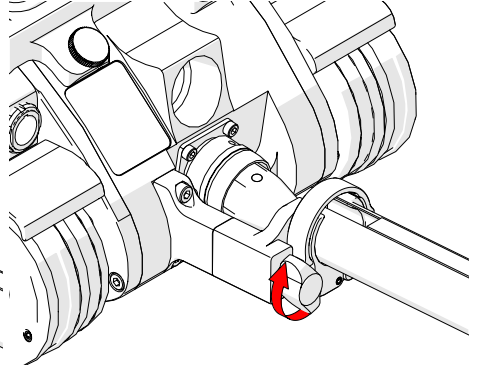

Fig. 181 - Tighten wing knob

1. Align the cable management clamp with the appropriate mounting position on the scanner (*Fig. 180*).
2. Tighten the cable management clamp wing knob (*Fig. 181*).

### 5.11.2.2 Cable Management Setup

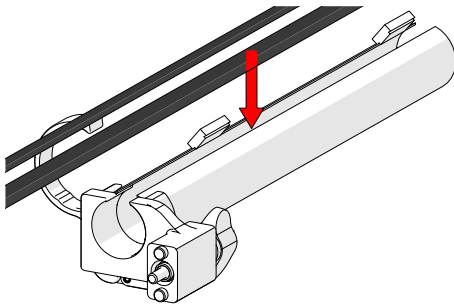

Fig. 182 - Insert cables and hoses

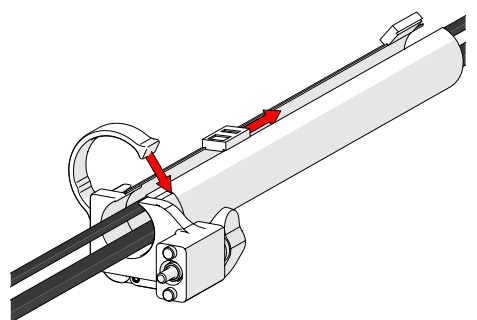

Fig. 183 - Zip to close

1. Open the cable management. Begin at the clamp end and start placing the cabling in the tube (*Fig. 182*).
2. Follow the cable placement, zipping the tube closed (*Fig. 183*).

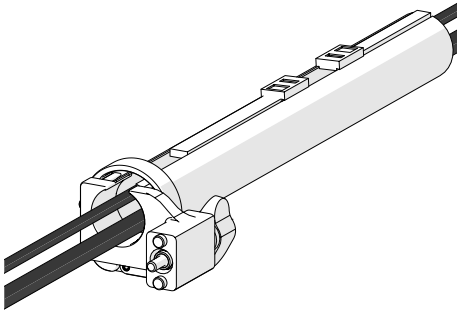

Fig. 184 - Zip opposite end

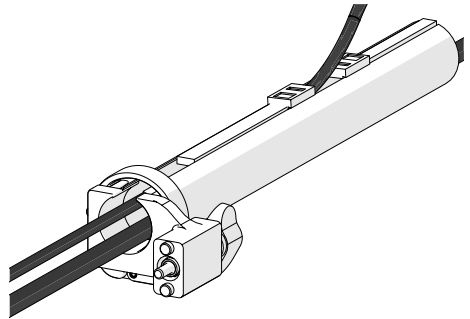

Fig. 185 - Flexible routing

3. Once the cable is placed the entire length of the tube, bring the zipper from the opposite end to meet at any point in the middle.

When necessary, the two zippers may be opened to allow any cables to be routed out of the tube.

### 5.11.2.3 Clamp Setup

In the event the tube becomes disconnected from the cable management clamp, follow these instructions to reattach the tube and clamp.

Loosen the clamp screw using the supplied 3 mm hex driver. Slide the clamp around the tube first, and then slide the tube around the outside of the cable management mount (Fig. 186). Align the zipper opening and the cable management clamp opening.

Slide the clamp over the tube and cable management mount, pinching the tube in between (Fig. 187).

Tighten the clamp screw (Fig. 188).

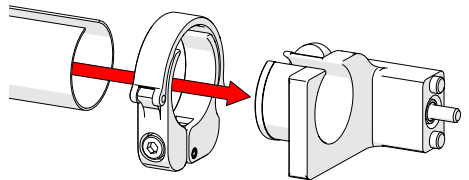

Fig. 186 - Slide tube around mount

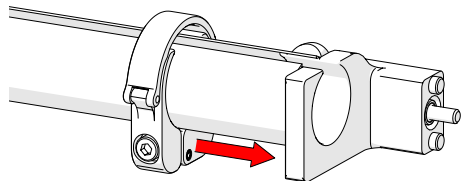

Fig. 187 - Slide clamp onto mount

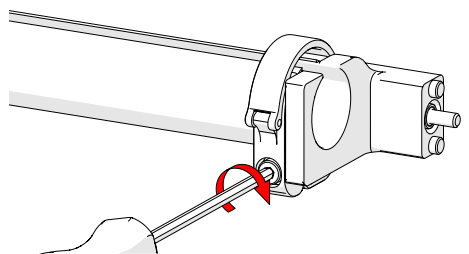

Fig. 188 - Tighten clamp screw

### 5.11.3. Preamp Bracket

Compatible with most standard preamps, use screws or the optional velcro straps to attach a preamp to the preamp bracket.

Intended Use

- ▶ The preamp bracket is intended to mount objects (e.g. preamps, splitters, etc.) that:
  - ▶ have a maximum weight of 1.36 kg (3 lb)
  - ▶ are attached to the **SKOOT** with a lanyard or probe cables strong enough to prevent the object from falling
  - ▶ have smooth edges so as not to cut the bracket's velcro strap

#### 5.11.3.1 Mounting Preamp Bracket

The preamp bracket mounts to any dovetail groove.

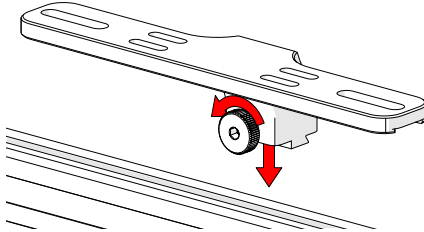

Fig. 189 - Loosen knob and mount to dovetail groove

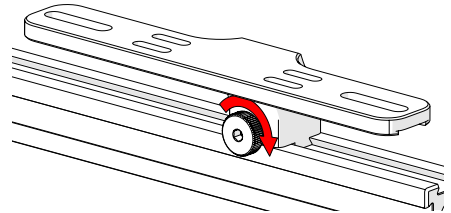

Fig. 190 - Tighten knob

1. Loosen the knob and align with the dovetail groove (Fig. 189).
2. Tighten the knob to lock the preamp bracket in place (Fig. 190).

#### 5.11.3.2 Attaching Preamp with Screws

Use the adjustable screw mounting channel on the bottom of the bracket (Fig. 191) to attach a preamp (screws not included).

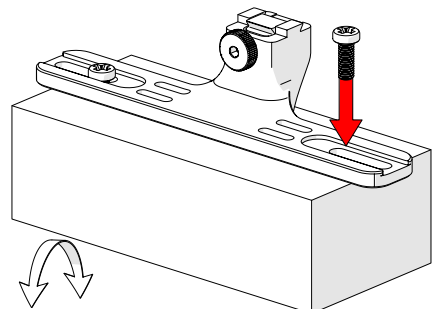

Fig. 191 - Attach preamp with screws

### 5.11.3.3 Attaching Preamp with Velcro Straps

To attach the preamp to the bracket using velcro straps (*sold separately*), follow these steps:

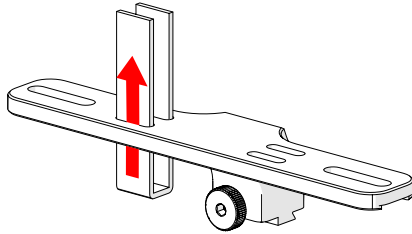

Fig. 192 - Insert velcro straps

1. Slide the velcro strap through the bracket's holes (*Fig. 192*).
2. Centre and place the preamp on the bracket wrapping the velcro around the preamp (*Fig. 193*).
3. Secure the preamp to the bracket attaching each side of the velcro (*Fig. 194*).

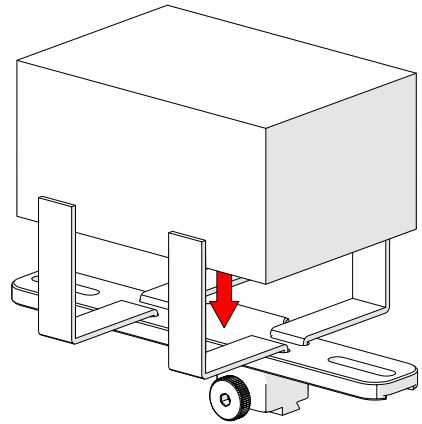

Fig. 193 - Place preamp and wrap velcro

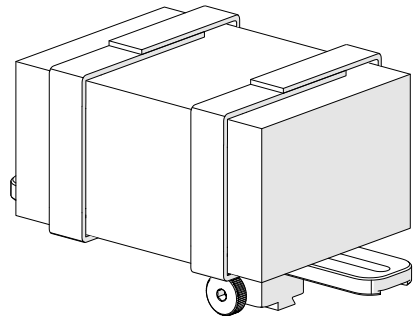

Fig. 194 - Mount bracket on a frame bar

## OPERATION

### 6.1. System Startup

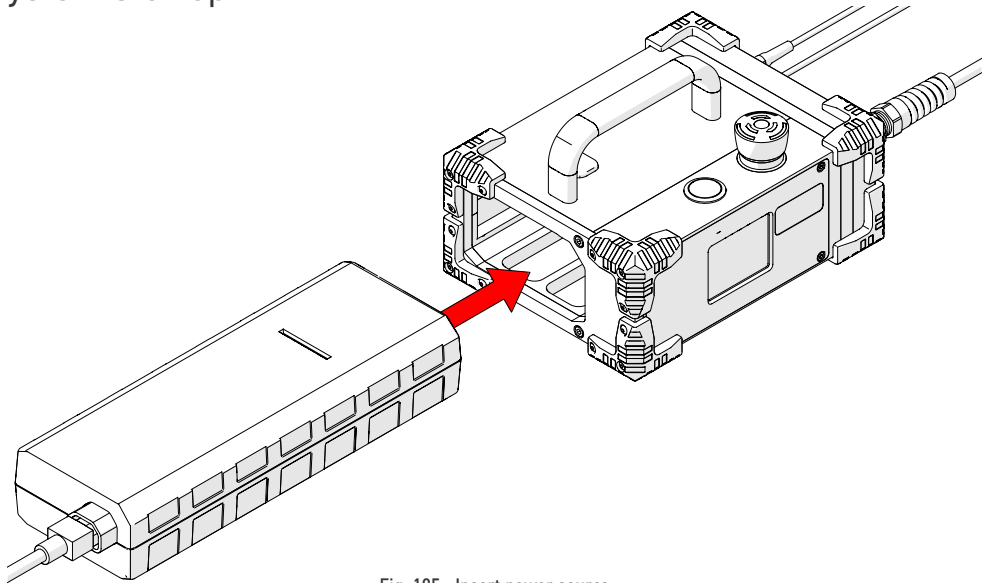

Fig. 195 - Insert power source

To activate the system, follow these steps:

1. Insert the power source (Fig. 195) into the power controller dock.
2. Connect the components (see "Configurations" on page 37).

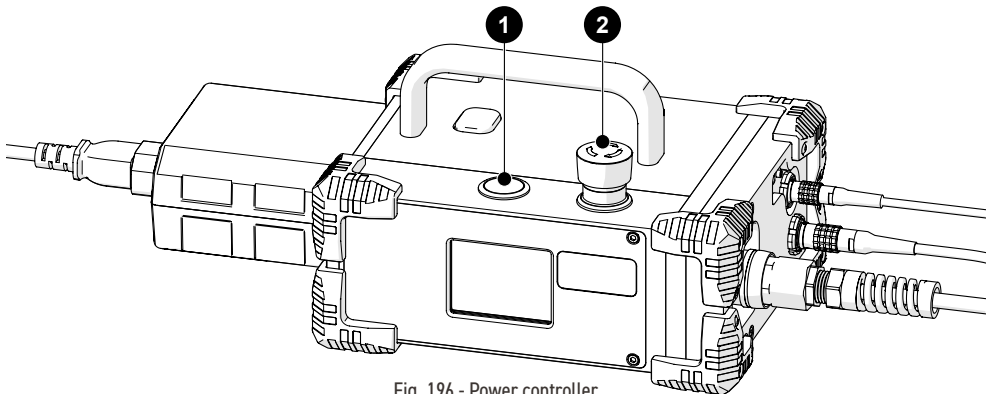

Fig. 196 - Power controller

3. Locate the **2** red stop push-button on the power controller. Rotate this button clockwise to unlatch (Fig. 196).
4. The **1** power button (Fig. 196) on the power controller activates the system.

**NOTE:** If the crawler is moving due to an external force when power is applied, the system will display a “Please Wait – Motor Moving” message until the movement stops. The crawler must be stationary for system initialization to be performed.

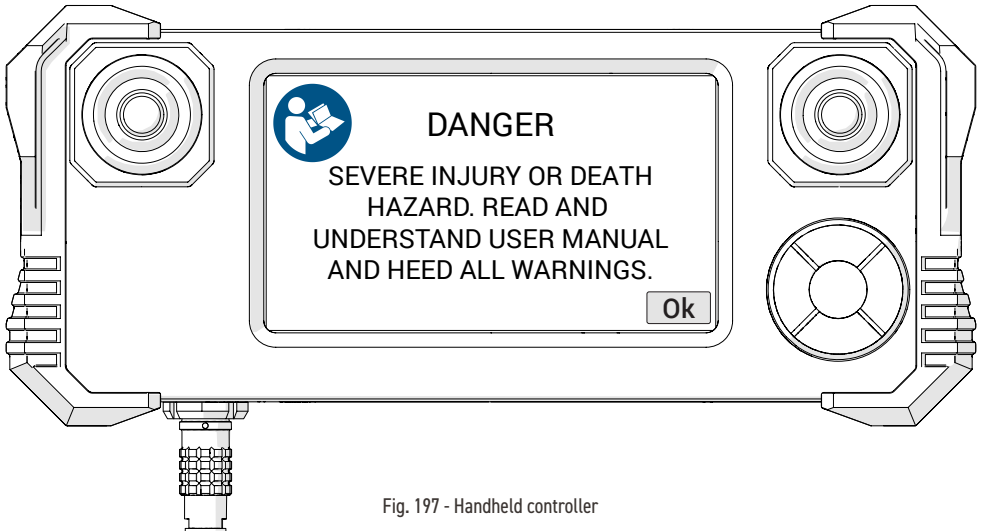

Fig. 197 - Handheld controller

5. A warning message will display on the handheld controller when power has been activated (Fig. 197). Once the dangers of using the **SKOOT** are recognized and understood by reading this user manual, touch **Ok** to acknowledge the warning.

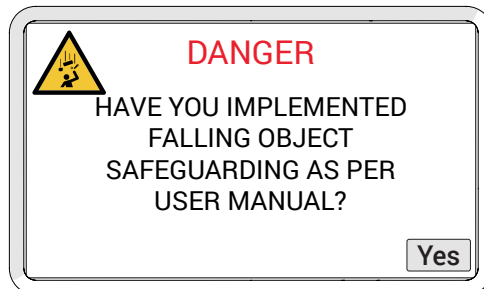

Fig. 198 - Falling object warning

6. A second warning message (Fig. 198) will display requesting assurance that a No Entry Fall Zone has been established (see “Preparation for Safe Use” on page 32) and tether requirements are met (see “Tether Requirements and Attachment” on page 33). Acknowledge this warning by touching **Yes**.

Once the system is initialized, the **Mode Select** screen will appear (see “Mode Select Screen” on page 97). The system is now ready for operation.

## 6.2. Placement of Crawler on Inspection Surface



### **WARNING! FALLING OBJECT HAZARD.**

Read and understand the proper procedure for using the Installation/Removal Mat. If crawler installation is done at elevated heights, improper use may cause the crawler to fall and **SEVERE INJURY** or **DEATH** could result.



**CAUTION!** Do **NOT** handle crawler using the umbilical cable. Use the provided handle.



**CAUTION!** To place the crawler on the inspection surface, use the scanner installation/removal mat (*Fig. 27*) as a spacer between the wheels and the surface on which the crawler is to drive. This is necessary to protect the electronic components within the crawler from damaging shock, should the crawler be slammed directly onto the surface.



**WARNING! MAGNETIC MATERIAL.** The wheels of the crawler produce an extremely strong magnetic field which may cause failure or permanent damage to items such as watches, memory devices, CRT monitors, medical devices or other electronics.



Tools, magnets and metal objects can cut, pinch or entrap hands and fingers. **HANDLE WITH CARE.**

People with pacemakers or ICD's must stay at least 25 cm (10 in) away.

**WARNING! MAGNETIC MATERIAL.** The installation/removal mat contains magnetic material. Those with pacemakers or ICD's must stay at least 10 cm (4 in) away.



## 6.2.1. Scanner Installation/Removal Mat Use

To place the crawler on the inspection surface, follow these steps:

**NOTE:** For scanner installation/removal on inspection surfaces with a temperature between 50°C and 150°C (122°C and 302°C), use the medium temperature installation/removal mat found in the automated crawler medium temperature add-on kit. Also, ensure the medium temperature cable management is used in place of cable management (see “Cable Management” on page 87)

**NOTE:** The manufacturer recommends two persons install the crawler on an inspection surface. One person to lower the crawler to the scan surface, and one person to operate the crawler via the handheld controller.

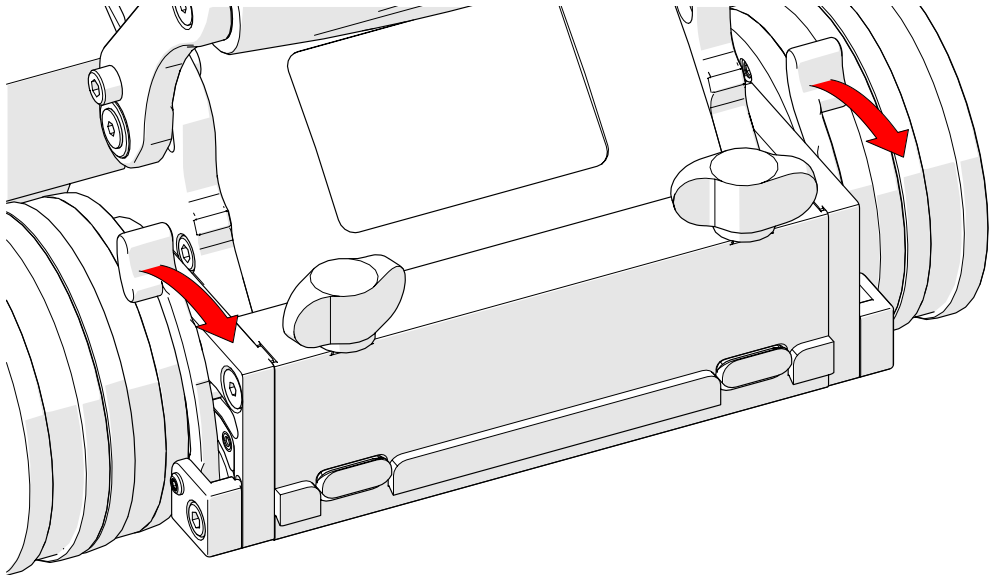

Fig. 199 - Front swivel adjustment levers

1. Ensure crawler preparation is complete (see “Preparation for Use” on page 32) and system startup has been performed (see “System Startup” on page 91).
2. Release the front swivel adjustment levers (Fig. 199), at the front of the crawler, to position the front swivel mount.
3. Raise the front swivel mounts to ensure they will not hinder the wheels from contacting the inspection surface (see “Swivel Mount” on page 45).
4. Set the crawler to Jog Mode (see “Jog Mode” on page 98).

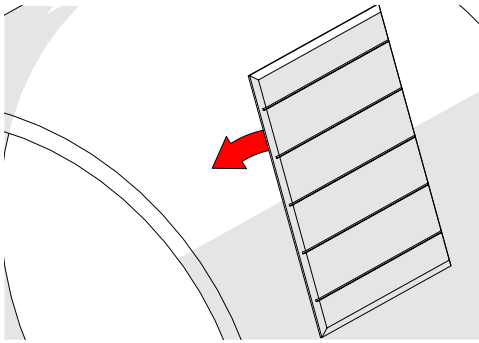

Fig. 200 - Place installation/removal mat

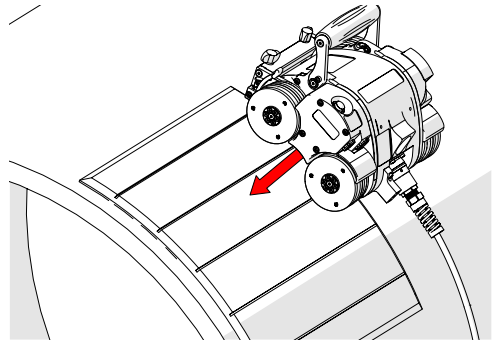

Fig. 201 - Lower crawler to mat

5. Place the installation/removal mat on the inspection surface (Fig. 200).
6. Place and hold the crawler on the installation/removal mat (Fig. 201).

**NOTE:** Do **NOT** release the crawler when placed on the installation/removal mat.

7. Ensure all four crawler wheels are held firmly against the installation/removal mat. While holding the crawler, use **Jog Mode** (see “Jog Mode” on page 98) to carefully drive the crawler (Fig. 202) off the installation/removal mat and onto the inspection surface (Fig. 203).

**TIP:** Avoid the crawler slamming to the inspection surface. This can occur when all four wheels are not in contact with the installation/removal mat while the crawler is driven onto the inspection surface.

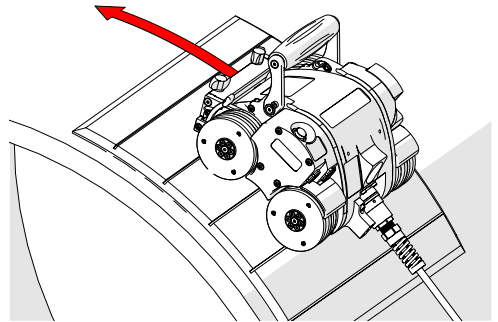

Fig. 202 - Drive crawler off the mat

8. Remove the installation/removal mat from the inspection surface.

**TIP:** Circumstance may arise when only one person is available for placement of the crawler on an inspection surface. With the system power off, it is possible to place the crawler on the inspection/removal mat and manually push the crawler off the mat and onto the inspection surface.

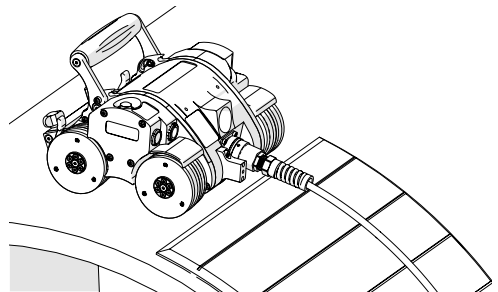

Fig. 203 - Magnetized to surface

## 6.3. Operation

### 6.3.1. Handheld Controller Layout

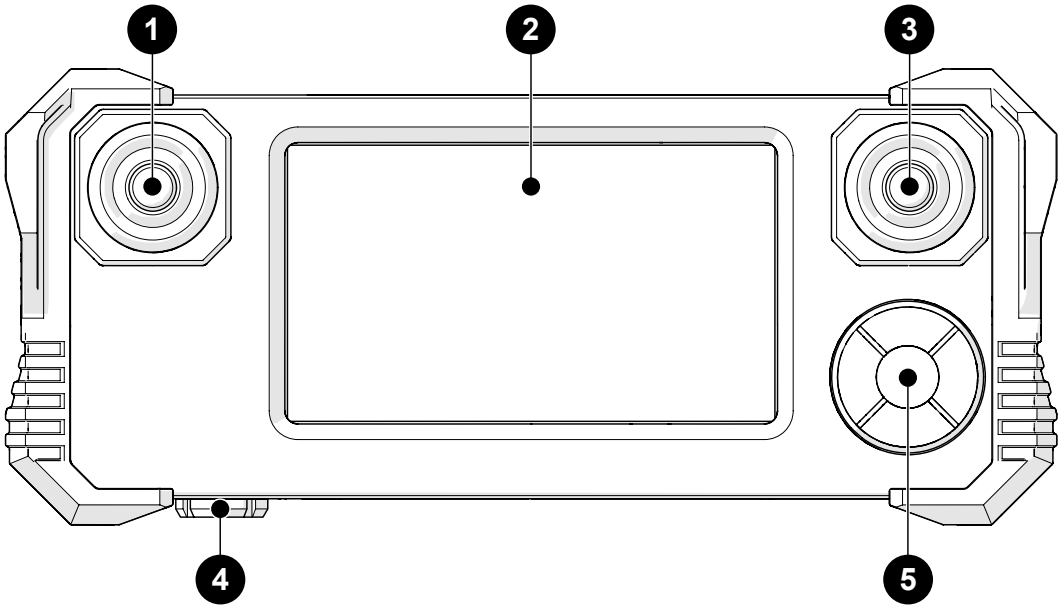

Fig. 204 - Handheld Controller

<b>1</b>	Fwd/Rev joystick	(see "Joysticks" on page 97)
<b>2</b>	Touchscreen	(see "Touchscreen" on page 96)
<b>3</b>	Raster joystick	(see "Joysticks" on page 97)
<b>4</b>	Controller cable connector	Connection point for the auxiliary cable.
<b>5</b>	D-pad	A means of navigating the on-screen menus of the handheld controller.

#### 6.3.1.1 Touchscreen

The **2** handheld controller's touchscreen is the primary operator interface for the system (Fig. 204). Buttons are indicated on-screen with a red border.

### 6.3.1.2 D-pad

The **5** D-pad provides a redundant system control that may be utilized as an alternative to the touchscreen. A blinking box around a button indicates the D-pad selection. Pressing the outer buttons of the D-pad selects different buttons on-screen. Press the centre button of the D-pad to choose the button currently selected.

### 6.3.1.3 Joysticks

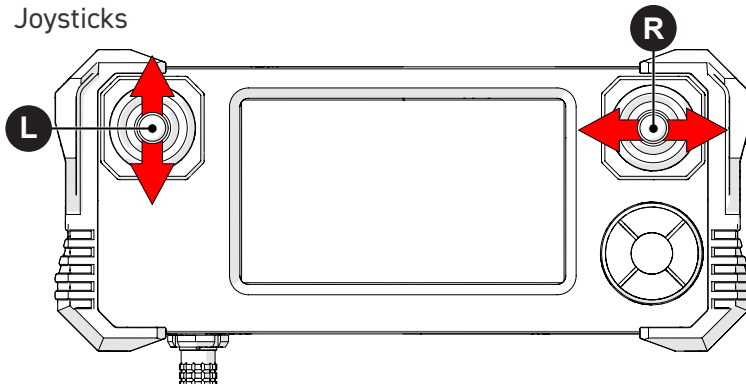

Fig. 205 - Handheld controller joysticks

The joysticks control system motion (Fig. 204). The **L** left joystick controls the crawler's forward/reverse movement. The **R** right joystick function is selected on the screen. Functions include raster arm movement (Fig. 205).

## 6.3.2. Mode Select Screen

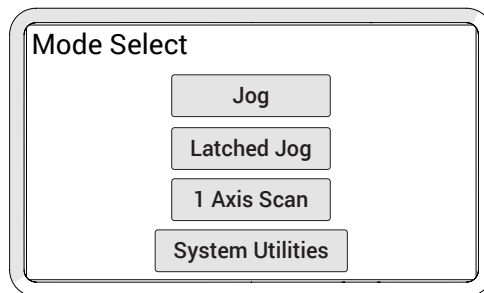

Fig. 206 - Mode select

The **Mode Select** screen offers four modes of operation for the system:

Jog Mode	(see "Jog Mode" on page 98)
Latched Jog Mode	(see "Latched Jog Mode" on page 99)
1 Axis Scan Mode	(see "1 Axis Scan Mode" on page 100)
System Utilities	(see "System Utilities Screen" on page 103)

### 6.3.3. Jog Mode

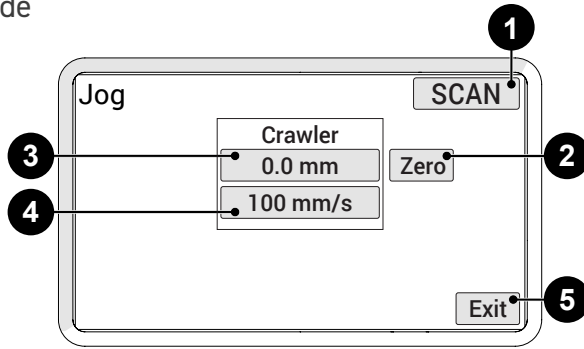

Fig. 207 - Button identification

Jog mode manually controls the system movement using the joysticks.

- |  |  |
|--|--|
| <b>1</b> Scan/Rapid Button<br>(Fig. 207)   | Used to quickly switch between crawler speeds. The speed in either mode can be manually set to the user's preference.  |
| <i><b>TIP:</b> Fine adjustments to speed can be made in the User Settings (see "User Settings Screen" on page 104).</i>  |  |
| <b>2</b> Zero Button   | Sets the current position to zero for all modules.   |
| <b>3</b> Module Position Button(s)   | Displays the current position of the crawler. Press to set the position to any value using the <b>Edit</b> screen. When a module position is modified, the position will be modified for all other system modes.   |
| <i><b>NOTE:</b> This function only zeroes the number displayed on the <b>SKOOT</b> handheld controller. It does not zero the position used in the data acquisition instrument.</i> |  |
| <b>4</b> Module Rate Button(s)   | Displays the current maximum rate for the selected speed mode. Press to set the maximum rate using the <b>Edit</b> screen. The movement commanded by the joysticks will be limited to the indicated rate. When a rate is modified, the rate will be modified for all other system modes. |
| <b>5</b> Exit Button   | Exits the jog mode and returns to the <b>Mode Select</b> screen.   |

### 6.3.4. Latched Jog Mode

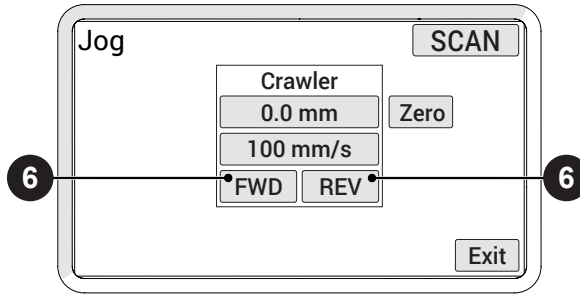

Fig. 208 - Latched jog mode

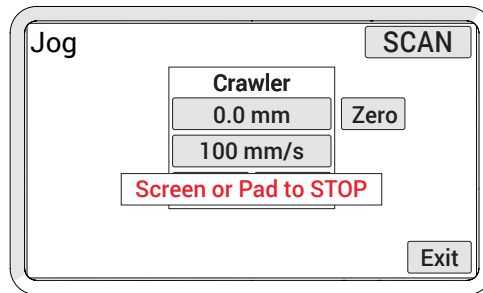

Fig. 209 - Latched jog stop screen

Identical to standard jog mode, latched jog mode adds forward or reverse crawler movement at the selected scan rate. This eliminates the need to manually hold the left joystick (see “Jog Mode” on page 98).

#### 6 FWD & REV Buttons:

The **FWD** and **REV** buttons are located in the crawler tab. Press the **FWD** or **REV** button to drive the crawler at the current maximum scan rate. Touching the handheld controller screen or pressing the D-pad stops crawler movement.

**NOTE:** The FWD & REV Buttons will not be present in rapid mode.

### 6.3.5. 1 Axis Scan Mode

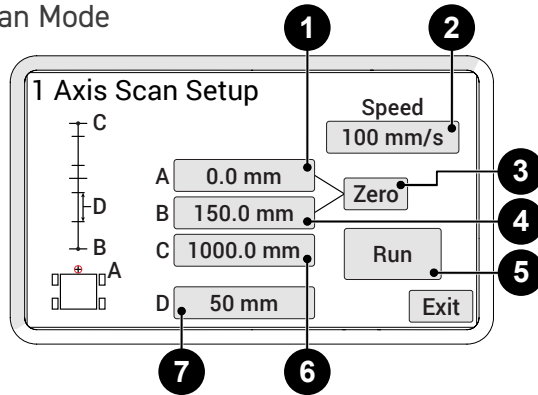

Fig. 210 - 1 Axis scan mode

1 Axis Scan mode drives the crawler in a straight line, stopping at programmed intervals.

1	Point A	The current encoder position of the crawler.
2	Speed Button	Access the <b>User Settings</b> screen to set the crawler's scan speed.
3	Zero Button	Set the numerical value for rows <b>A</b> and <b>B</b> to zero.
4	Point B	The start point of the scan travel. The system will move the scanner from the <b>A</b> point to this point at the start of a scan.
5	Run Button	Enables the <b>1 Axis Scan</b> screen (see "1 Axis Scan Screen" on page 101).
6	Point C	The finish point of the overall scan travel.
7	Setting D	The distance the system will advance.

The **1 Axis Scan Setup** screen indicates the scan functions that may be entered. Each point and setting, **A**, **B**, **C**, **D**, corresponds to a coordinate entry button on the screen.

A typical scan begins at the **A** position and moves to the **B** position. Scanning begins at the **B** position and scans the distance of **D** until the **C** position is reached.

### 6.3.5.1 1 Axis Scan Screen

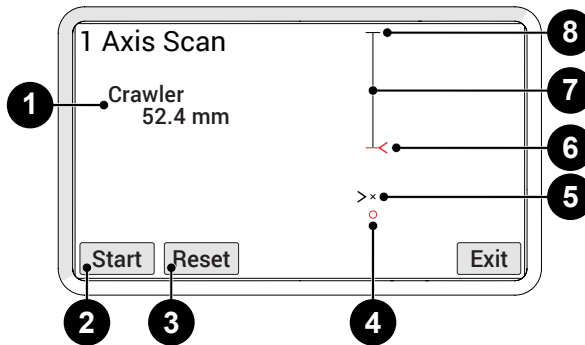

Fig. 211 - 1 Axis scan screen

The **1 Axis Scan** screen initiates and monitors the scan and advances the set distance. The initial scan screen is an approximation of a full view (*zoomed out*) of the entire scan path.

<p><b>1</b> Crawler (Motor) (Fig. 211)</p>	<p>The current encoder position of the crawler. If an idler encoder is available, it will also indicate the encoder selected (<i>Motor or Idler</i>) for crawler positioning as set in the User Settings (see “User Settings Screen” on page 104).</p>
<p><b>2</b> Start/Stop button</p>	<p>Start or stop the scan sequence. When a scan has been stopped while in progress, the start button resumes the scan.</p>
<p><b>3</b> Reset</p>	<p>Return the scanner to the <b>A</b> position. Press the start button to begin the scan sequence from the initial setting.</p>
<p><b>4</b> Scan location</p>	<p>Small red circle indicates the <b>A</b> position.</p>
<p><b>5</b> Scanner position</p>	<p>The blinking cross hair indicates the current scanner position.</p>
<p><b>6</b> Next scanner position</p>	<p>Where the scanner will travel to next.</p> <p><b>NOTE:</b> The red indicator is always where the scanner will go next.</p>
<p><b>7</b> Summary screen</p>	<p>A visual representation of the scan area.</p>
<p><b>8</b> End position</p>	<p>The completed distance of programmed travel.</p>

When Start is pressed the first time, the scanner will travel to point **B** and pause. The summary screen shows a closer view (*zoom in*) of the scan path.



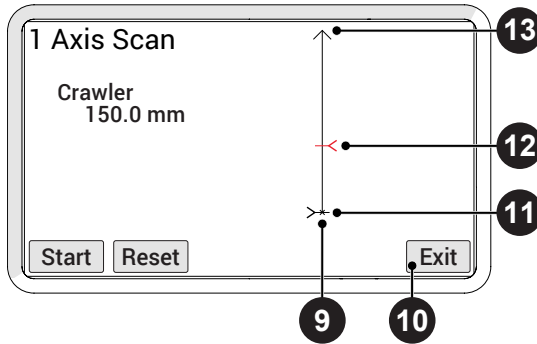

Fig. 212 - 1 Axis scan screen

- |   |  |
|---|--|
| <p><b>9</b> Scanner location</p> <p><b>10</b> Exit button</p> | <p>The current encoder position of the crawler.</p> <p>Pressing <b>Exit</b> stops all scanning motion. When the scanner is not in the <b>A</b> position, a warning appears (Fig. 213). The warning alerts that the <b>A</b> position of the scanner will be changed to the current position.</p> |
|---|--|

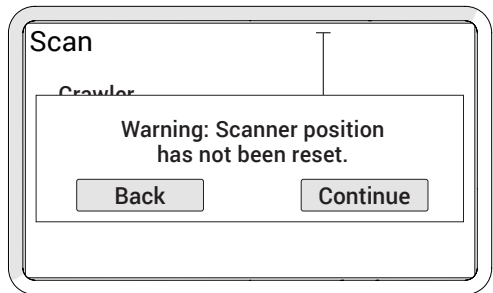

Fig. 213 - Exit warning

Press **Back** to return to the **1 Axis Scan** screen to reset the scanner and maintain the original **A** position. Press **Continue** to exit to the **1 Axis Scan Setup** screen.

- |   |   |
|---|---|
| <p><b>11</b> Scanner position</p> <p><b>12</b> Next scanner position</p> <p><b>13</b> End point</p> | <p>The blinking cross hair indicates the scanner position.</p> <p>When the scanner will travel to next.</p> <p>The arrow indicates the travel will continue to advance. A straight line indicates the end of programmed travel.</p> |
|---|---|

### 6.3.6. System Utilities Screen

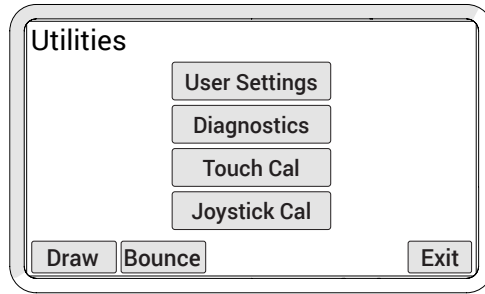

Fig. 214 - Utilities screen

The **Utilities** screen provides access to the setup, diagnostics and user preference settings.

User Settings Button (Fig. 214)	Access the <b>User Settings</b> screen allowing for various user preferences to be adjusted.
Diagnostics Button	Enters the <b>Diagnostic</b> screens to monitor system components and function.
Touch Cal Button	Used to initiate the <b>Touch Calibration</b> screen.
Joystick Cal Button	Used to enter the <b>Joystick Calibration</b> screen.
Draw Button	Enters mode used to test the touch screen accuracy and response.

### 6.3.6.1 User Settings Screen

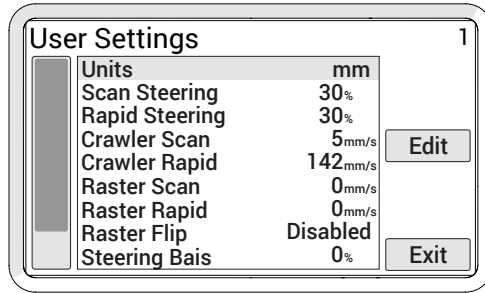

Fig. 215 - User settings screen

Allows a user to customize the system to their preferences.

Use the touch screen or D-pad to select different settings.

Press **Edit** to enter the **Edit** screen to apply changes to the selected setting.

Title	Description	Valid Range	Default
Units	Change the measurement units for display and user entry. When set to 0, units measure in inches. When set to 1, units measure in millimetres.	inches or mm	mm
Crawler Scan	Sets the crawler scan rate in the current units/second. This setting may also be changed within other modes.	5-142 mm/s (0.2-5.6 in/s)	43 mm/s (1.7 in/s)
Crawler Rapid	Sets the crawler rapid rate in the current units/second. This setting can also be changed through the Jog screen.	5-142 mm/s (0.2-5.6 in/s)	142 mm/s (5.6 in/s)
Display Brightness	Sets the brightness of the display.	0-100	100%

### 6.3.6.2 Diagnostics Screens

Several diagnostic screens allow various system functions to be monitored. Navigate to different diagnostic screens using the **PREV** and **NEXT** buttons. The **Exit** button returns to the **System Utilities** screen.

**NOTE:** *The diagnostic information requires an in-depth understanding of the underlying technologies and programming in the system. Not all functions and information is explained in this manual.*

#### 6.3.6.2.1. Detected Modules

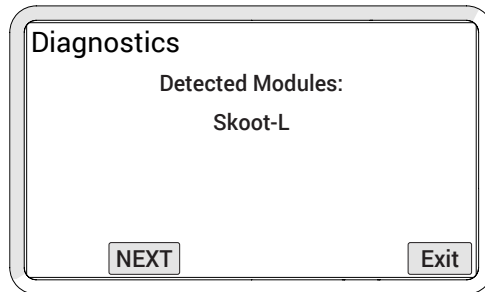

Fig. 216 - Detected modules screen

The screen indicates the system software version and displays which modules were detected when the system was activated.

### 6.3.6.2.2. System 1

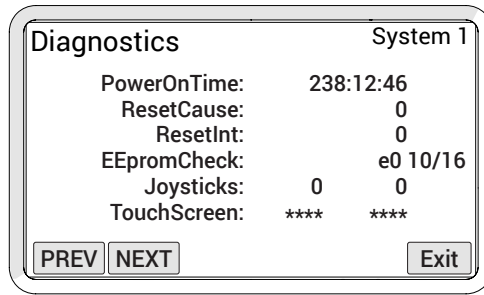

Fig. 217 - Diagnostic screen

System 1 diagnostic screen displays general system function information.

PowerOnTime	The total accumulative time the handheld controller has been powered.
Joysticks	Indicates the raw position reading from the joysticks.
TouchScreen	Indicates the raw position reading from the last touchscreen contact.

### 6.3.6.2.3. System 2

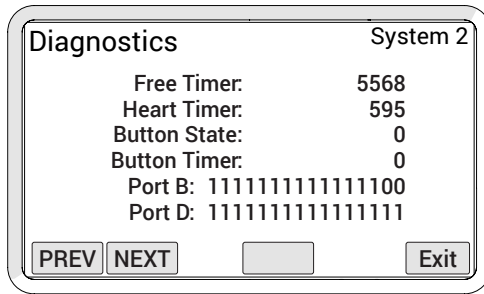

Fig. 218 - Diagnostic screen

Additional general system function information is displayed within the **System 2** screen. An empty button is provided to allow testing of the D-pad.

Free Timer	Value from a free running system timer. If this timer is static, an internal controller issue is present.
Button State	Shows the state of the push-buttons in the D-pad.
Button Timer	Shows the timer associated with the D-pad.

### 6.3.6.2.4. System 3

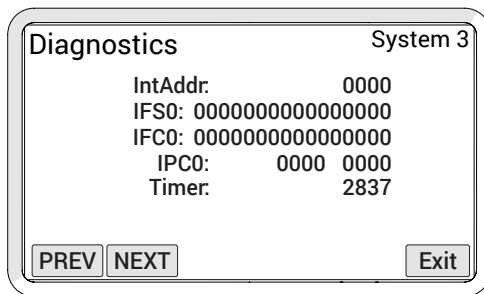

Fig. 219 - Diagnostic screen

The **System 3 Diagnostic** screen displays additional system information. The information provided does not typically assist the user.

### 6.3.6.2.5. Skoot-L

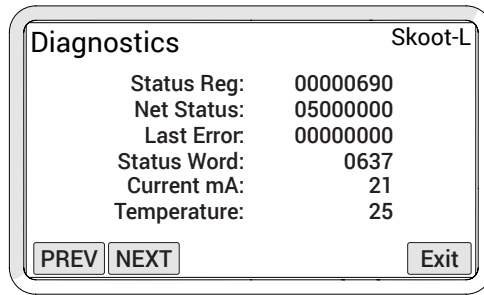

Fig. 220 - Diagnostic screen

**The Skoot-L diagnostic** screen provides information regarding the status of the crawler. A separate screen is available for each module detected upon system startup.

#### Current MA

Displays the output of the crawler to the motor. The current (mA) displayed is directly proportional to the motor's output torque. This reading can be used to check if the control system is responding to forces on the module's motor.

#### Temperature

Internal temperature reading of the crawler in degrees Celsius.

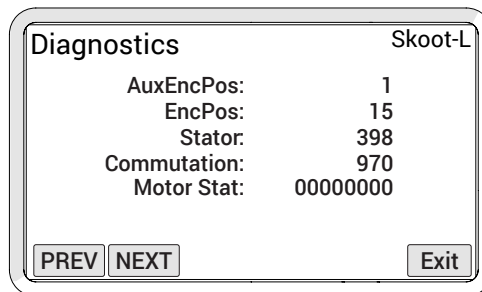

Fig. 221 - Diagnostic screen

AuxEncPos	Displays the position of the auxiliary encoder in counts when connected to the module. When the auxiliary encoder is moved, this number will change. When the encoder is moved from its current position and then back to that exact same position, this number will also return to its original position.
EncPos	The position of the modules motor encoder in counts.

### 6.3.6.3 Touch Calibration Screen



Fig. 222 - Touch calibration screen

This option allows calibration of the touch screen. Typically, this should not be necessary.

Touch the screen as the markers appear in the four corners of the screen.

**TIP:** *It is recommended that the markers be touched with a small object to enhance the touch position accuracy during calibration.*

The new calibration is stored immediately when the fourth marker is pressed. The calibration utility exits and return to the **System Utilities** screen. To abort the calibration, the system power may be turned off before the last marker is pressed.



### 6.3.6.4 Joystick Calibration Screen

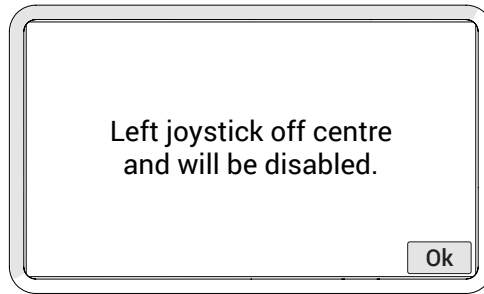

Fig. 223 - Joystick error

Typically joystick calibration is only necessary when a joystick off-centre error is detected upon startup (*Fig. 223*). Calibration may also be used when a joystick function does not appear to be properly centred.

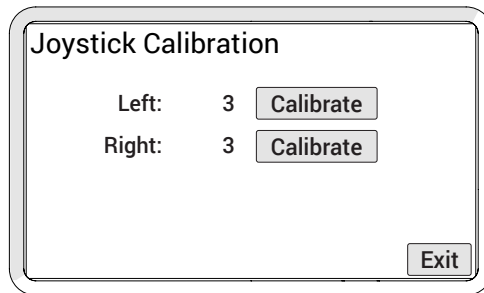

Fig. 224 - Joystick calibration screen

Current readings of the joysticks are displayed on the **Joystick Calibration** screen (*Fig. 224*). When the numbers are not near zero, press the **Calibrate** button to recalibrate to 0. The new calibration is stored when the **Exit** button is pressed.

### 6.3.6.5 Draw



Fig. 225 - Draw utility

The draw utility may be used to test the function of the touchscreen. Exit the utility by pressing the D-pad.

### 6.3.7. High Internal Temperature Screen



**CAUTION! HOT SURFACE.** The handles of the crawler and crawler body may be hot to the touch. Use appropriate protective equipment when removing a crawler from a high temperature surface.

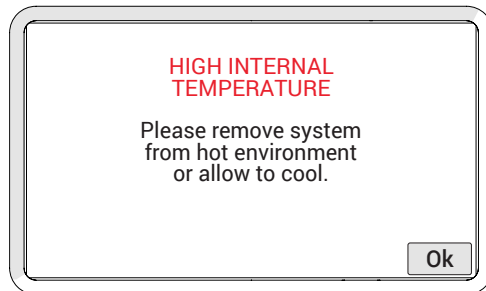

Fig. 226 - High internal temperature screen

The high internal temperature screen will display when the system approaches its maximum operating temperature. All motor and system functions will cease when this alert screen is displayed.

Press **OK** to reactivate the system to remove **SKOOT** from the scan surface.

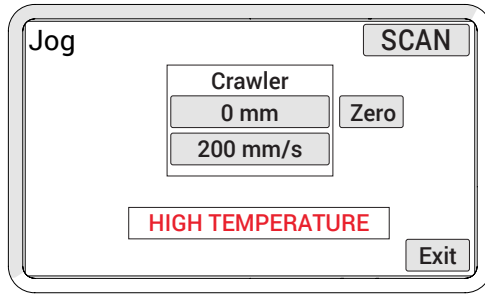

Fig. 227 - High internal temperature screen

Should the user continue operating the crawler, the HIGH TEMPERATURE warning will continue to display until the temperature falls below the set temperature limit.

## MAINTENANCE

### 7.1. Safety Precautions Before Maintenance



#### **WARNING! ELECTRICAL SHOCK**

**HAZARD.** Disconnect the power controller when servicing the equipment. The power controller is powered even when the stop push-button is latched in the off position.



#### **WARNING! MAGNETIC MATERIAL.**

The wheels of the crawler produce an extremely strong magnetic field which may cause failure or permanent damage to items such as watches, memory devices, CRT monitors, medical devices or other electronics.



Tools, magnets and metal objects can cut, pinch or entrap hands and fingers. **HANDLE WITH CARE.**

Those with pacemakers or ICD's must stay at least 25 cm (10 in) away at all times.

### 7.2. Cleaning

General cleaning of all components is important to keep the system working properly. All components that do not have wiring or cables are completely waterproof. Components can be washed with warm water, dish soap and a medium bristle brush. Before using the scanner, ensure that all connectors are free of water and moisture.

**TIP:** All components with wiring, cables or electrical connections are splashproof but not submersible.

**NOTE:** Never use strong solvents or abrasive materials to clean your scanner components.

## 7.3. Maintenance Schedule

The **SKOOT** system must be maintained according to the following schedule.

Task	Frequency
<u>Inspect safety apparatus</u> This includes: <ul style="list-style-type: none"><li>● All components of the tether system. Replace damaged components as necessary.</li><li>● Lifting sling on the crawler. If the lifting sling shows signs of damage (<i>e.g. cuts, abrasion, etc.</i>), do NOT use it.</li></ul>	Every Use
<u>Clean the drive wheels</u> Debris will collect on the magnetic wheels. Remove this debris before every use. An effective cleaning method uses adhesive-backed tape ( <i>e.g. duct tape</i> ) to 'pull' the debris off the wheels.	Every Use
<u>Inspect cables and connectors</u> Inspect the umbilical cable, the control cable and the power controller cable for damage. Have any damaged cable repaired by a qualified person or replace the cable assembly as necessary. Inspect all connectors for damage or moisture. Straighten bent pins. Dry connectors before using.	Every Use
<u>General cleaning</u> Ensure the scanner stays relatively clean by wiping off any excess dirt or other contaminants after every use.	Every Use

# TROUBLESHOOTING

## 8.1. Startup Issues

Two messages are possible in the event of a startup issue: **Joystick Off Centre** or **Checking Network**.

### 8.1.1. Joystick Off Centre

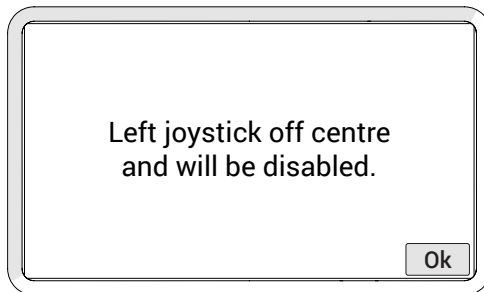

Fig. 228 - Joystick off centre screen

Upon system startup, the joystick positions are detected. When a joystick is detected outside the centre position, the **Joystick Off Centre** screen displays, indicating the joystick will be disabled. Press **Ok** to continue system startup. All system functions will work normally with the exception of movements that require joystick operation.

Ensure the handheld controller's joysticks are free of interference and reset the system power to enable joystick control.

If no interference of the joystick is present, the joystick calibration may need to be performed (see "Joystick Calibration Screen" on page 110)

### 8.1.2. Checking Network

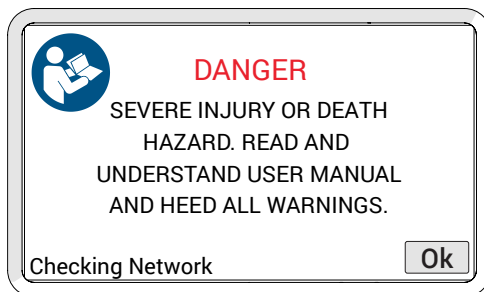

Fig. 229 - Checking network screen

During startup, the system initializes the communications to all the devices on the network. If the network communication fails for any reason, the **Checking Network** message will appear and remain on screen.

Likely causes of this failure:

1. No devices are connected to the network.
2. A problem with one of the devices.
3. Cable issue causing the entire network to fail.

Check the connections of the devices or try removing one device at a time from the system to isolate the problem device.

**NOTE:** Always turn off the system power before connecting or disconnecting any devices.

## 8.2. Startup Override

A system maintenance mode may be accessed to correct system issues. Enter the maintenance mode by pressing the handheld controller D-pad while system power is activated. Continue pressing the handheld controller D-pad until the **Startup Override** screen appears.

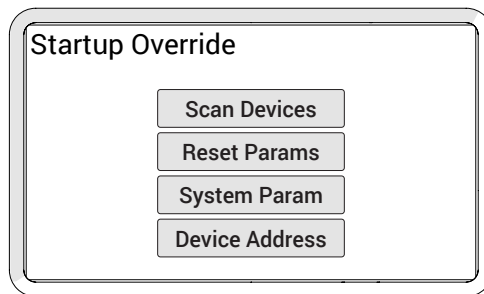

Fig. 230 - Startup override screen

## 8.2.1. Scan Devices

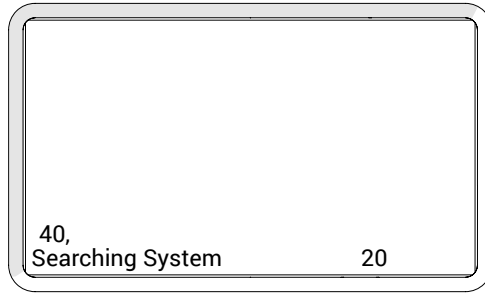

Fig. 231 - Searching System screen

This utility scans the system network for devices. All possible device addresses and speeds are scanned. As devices are found, the address of the devices is displayed. When the scanning is complete, power to the system must be cycled.

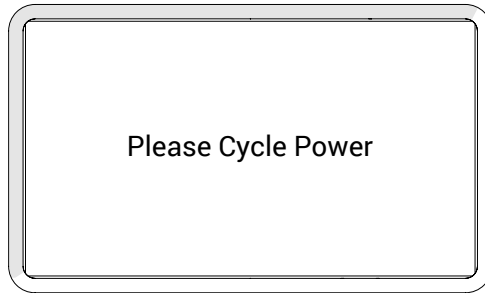

Fig. 232 - Cycle power screen

When a device is connected to the system but is not detected, this most likely indicates an internal device problem.



### 8.2.2. Reset Parameters

If the system parameters become corrupt or a change is made that prevents the system from functioning properly. All system parameters may be restored to their factory settings by selecting this option. When pressing the **Reset Params** button, the changes occur immediately. Power will need to be cycled for the reset to be complete.

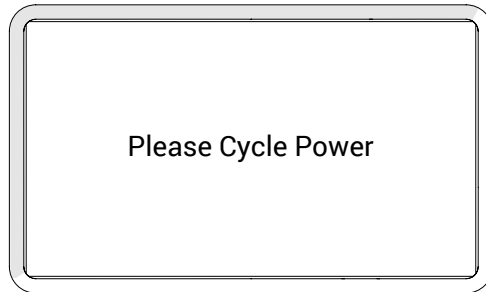

Fig. 233 - Cycle power screen

### 8.2.3. System Parameters

System parameters are factory set to control a variety of functions. These parameters can not be modified. However, special circumstances may occur when modification of these parameters could be recommended by the manufacturer.

Instructions for making changes to the system parameters will only be provided when deemed necessary by the manufacturer.

### 8.2.4. Device Address

Instructions for making changes to the system parameters will only be provided when deemed necessary by the manufacturer.

### 8.3. Additional Issues

Problem	Possible Cause	Solution
Handheld controller display does not activate	Input power requirements not met.	Ensure input power meets requirements. (see “Power Requirements” on page 8)
	Handheld controller not plugged into power controller.	Plug handheld controller into power controller. Ensure connectors are dry, clean and connector pins are not bent.
	Umbilical cable not properly connected.	Check umbilical cable connections at both ends. Ensure connectors are dry, clean and connector pins are not bent.
	<b>SKOOT</b> system not started.	Start the <b>SKOOT</b> system. (see “System Startup” on page 91)
	Damaged components in the controller, crawler, power controller or cabling.	Contact manufacturer. (see “Jireh Industries Ltd.” on page 1)
Handheld controller display is activated, yet the crawler does not drive	Handheld controller is not in the correct mode for driving.	(see Operation on page 96 for additional details).
	Damaged components in the handheld controller, crawler, power controller or cabling.	Contact manufacturer. (see “Jireh Industries Ltd.” on page 1)
Crawler does not drive and is unreachable	See possible causes for problem one of this list.	See solutions for problem one. If the crawler is still unresponsive (see “Retrieval of a Stranded Crawler” on page 120)
System displays “Please Wait – Motor Moving” when power is applied.	The crawler is moving when power is applied due to an external force (gravity, etc.).	Manually stop the crawler movement. The crawler must be stationary for system initialization to be performed.

For technical assistance (see “Technical Support” on page 120).

## 8.4. Retrieval of a Stranded Crawler



### **WARNING! FALLING OBJECT HAZARD.**

The tether system must remain active while retrieving the crawler (*i.e. a mechanism or person must be continuously taking up the slack in the tether*).

Should the **SKOOT** crawler become inoperative while out of reach, attempt first the solutions offered in this manual (*see “Troubleshooting” on page 115*)

If troubleshooting does not rectify the issue, it may be necessary to retrieve the crawler manually. To do so:

1. Press the stop push-button turning the crawler power off.

**NOTE:** Under normal conditions, the crawler should begin descending slowly.

2. If the crawler stops descending due to some kind of impediment, use a ladder, man lift or scaffolding to assist the crawler in overcoming the obstacle.

**NOTE: FALLING OBJECT HAZARD.** It is **CRUCIAL** that the tether system remains active while retrieving the crawler (*i.e. a mechanism or person must be continuously taking up slack in the tether*).

## 8.5. Technical Support

For technical support, contact Jireh Industries (*see “Jireh Industries Ltd.” on page 1*).

## SERVICE AND REPAIR



**WARNING! ELECTRICAL SHOCK HAZARD.** Disconnect the power controller when servicing the equipment. The power controller is powered even when the stop push-button is latched in the off position.



**WARNING! MAGNETIC MATERIAL.** The wheels of the crawler produce an extremely strong magnetic field which may cause failure or permanent damage to items such as watches, memory devices, CRT monitors, medical devices or other electronics.

Tools, magnets and metal objects can cut, pinch or entrap hands and fingers. **HANDLE WITH CARE.**

Those with pacemakers or ICD's must stay at least 25 cm (10 in) away at all times.



**WARNING! DO NOT DISASSEMBLE.** No user-serviceable parts. Disassembling any of the components in this product, beyond the instructions in this user manual, could void the regulatory certifications and/or effect the safety of the product.

# SPARE PARTS

To order accessories or replacement parts for your **SKOOT** system. (contact Jireh Industries Ltd. on page 1)

**NOTE:** These drawings are for parts order. This is not a list of kit contents.

## 10.1. Crawler

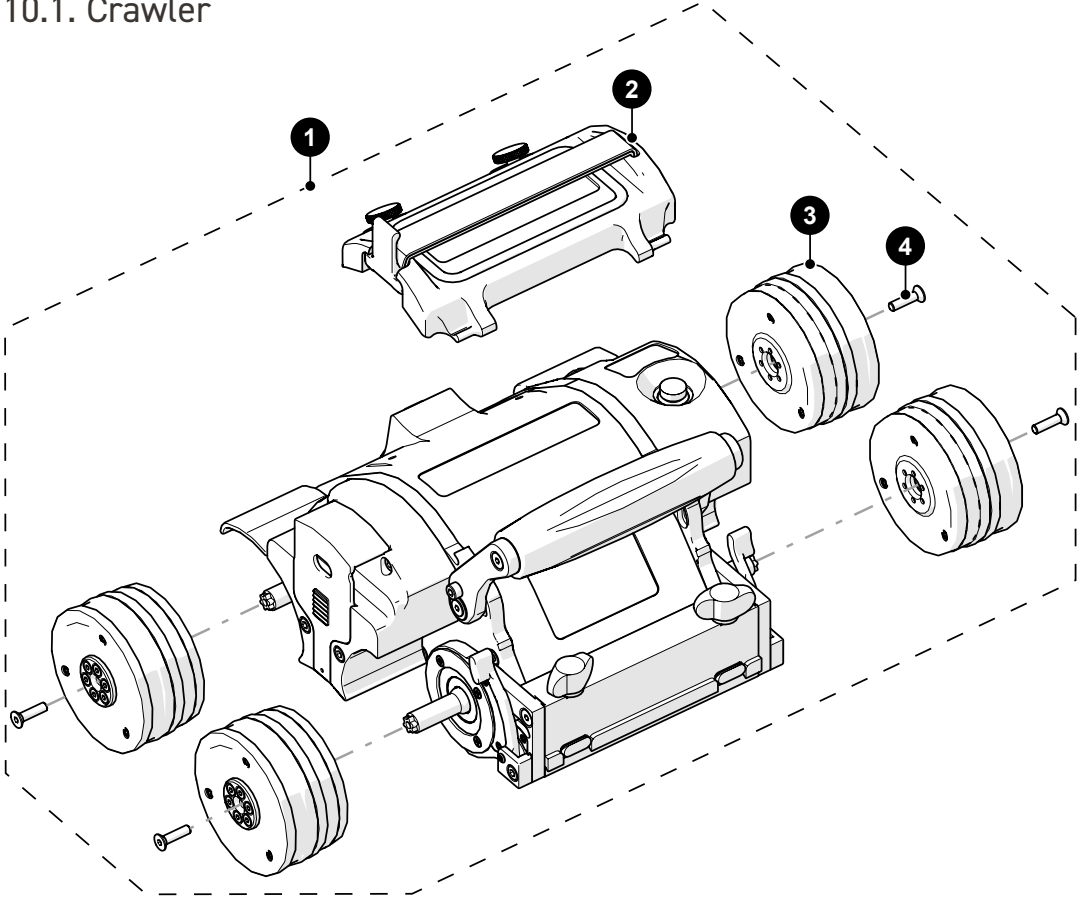

Fig. 234 - SKOOT base crawler spare parts

BOM ID	Part #	Description
1	DNA004	SKOOT Crawler
2	DNS008	Backpack
3	CXS005	Magnetic Wheel
4	MD029-016	FHCS, M4x0.7 X 12 mm, SST

## 10.2. Kit Components

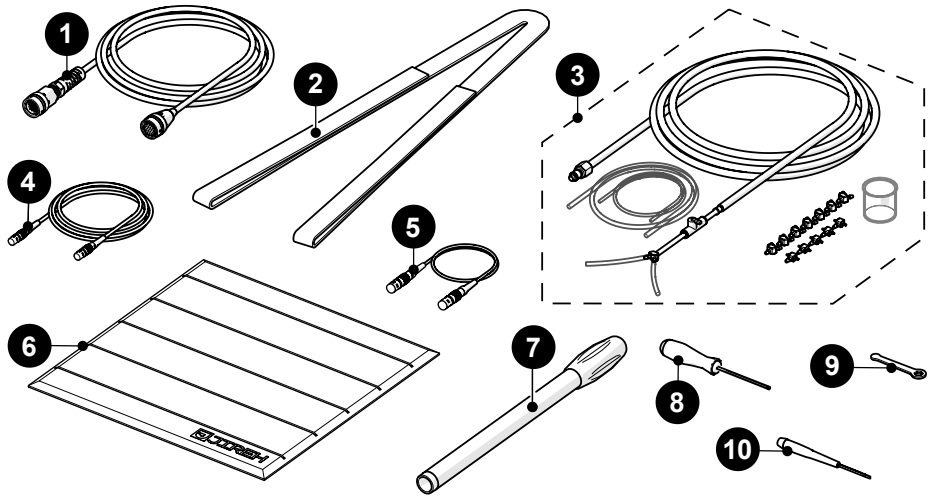

Fig. 235 - Kit components

BOM ID	Part #	Description
1	UMA022-X	Umbilical (various lengths available)
2	EA243	Sling
3	CMG009-X	Irrigation Kit, 2-4 Probe, Large Tube (Various lengths available)
4	UMA017-06	Auxiliary Cable, 6 m (19.7 ft)
5	UMA025-X-05	J300 Encoder Cable (see Encoder Connector Type)
6	AAS061	Installation/Removal Mat
7	DNS006	Manipulation Handle
8	EA414	3 mm (0.188 in) Hex Driver
9	EA470	10 mm (3/8 in) Wrench
10	EA480	3 mm (0.118 in) Flat Driver

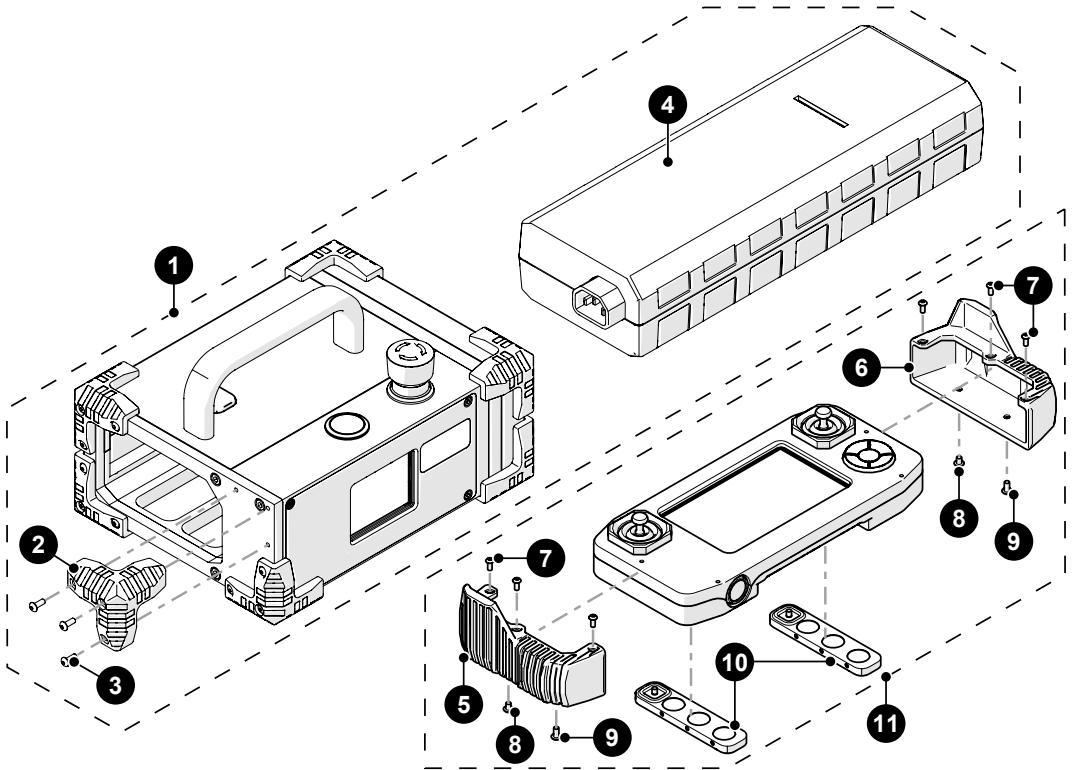

Fig. 236 - Kit components

BOM ID	Part #	Description
1	CXA040-	Power controller <i>(see Power Cord Type)</i>
2	DY0011	Rubber bumper
3	MD072-008	BHCS, M3x0.5 X 8mm, SST
4	CXS122	Power supply
5	DM0088-L	Handheld controller bumper <i>(left)</i>
6	DM0088-R	Handheld controller bumper <i>(right)</i>
7	MD409-006	BHCS-TX, M2.5x0.5 X 6mm ISO 7380-1 A2
8	MD411-004	BHCS-TX, M3x0.5 X 4mm ISO 7380-1 A2
9	MD411-006	BHCS-TX, M3x0.5 X 6mm ISO 7380-1 A2
10	DMS005	Handheld controller magnet holder
11	DMA006	Handheld controller

### 10.2.1. Encoder Connector Type

Connector Type	Company/Instrument	Connector Type	Company/Instrument
B	Olympus OmniScan MX Zetec Topaz	G	Sonotron Isonic 25xx
C	Olympus Focus LT Zetec Z-Scan Eddyfi Ectane 2	U	Sonatest Veo / Prisma
E	Olympus OmniScan SX/MX2/X3 M2M MANTIS/GEKKO LEMO	V	Pragma PAUT
F	TD ( <i>Technology Design</i> )	AD	Sonatest Veo / Prisma - Single Axis

**NOTE:** Additional encoder connector types are available.  
(contact Jireh Industries Ltd. on page 1)

### 10.2.3. Power Cord Type

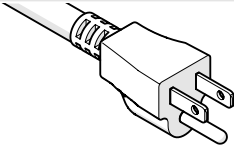
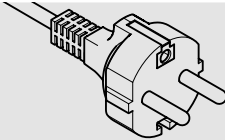
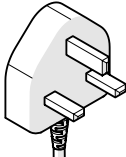
Connector Type	Part #	Power Cord	
N	SL032	North American	
E	SL039	European	
U	SL059	United Kingdom	
Z		No Cord	



### 10.3. Cable Management

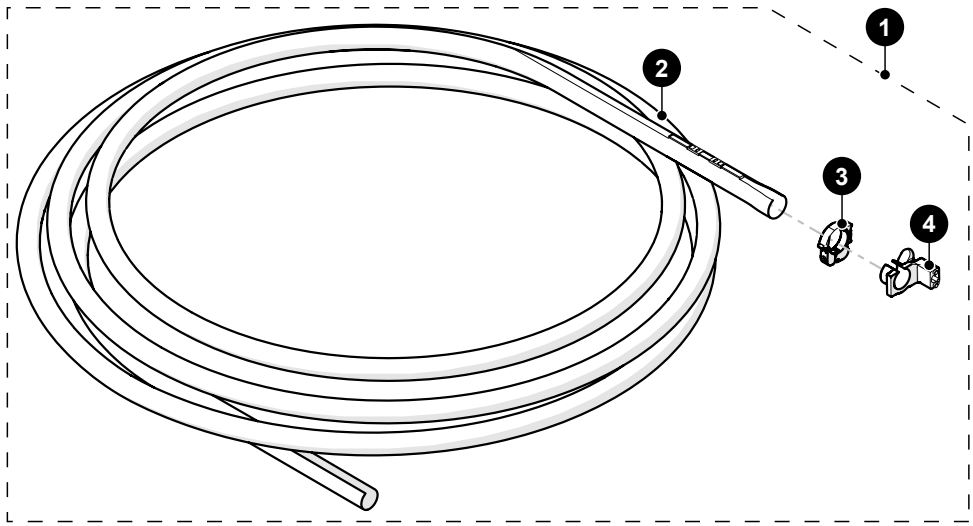
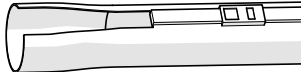
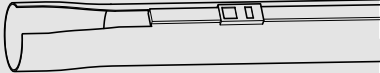



Fig. 237 - Cable management parts

BOM ID	Part #	Description
1	CXS046-X	Cable Management, Threaded Mount (see <i>Cable Management Sleeving, Length</i> )
2		see <i>Cable Management Sleeving</i>
3	CES066	Cable management clamp
4	CXS073	Cable management mount, threaded mount

#### 10.3.2. Cable Management Sleeving

Length	Part #	Description	
04.5	CX0141	4.5 m (14.8 ft)	
09.5	CX0145	9.5 m (31.2 ft)	
14.5	CX0146	14.5 m (47.6 ft)	
29.5	CX0147	29.5 m (96.8 ft)	

## 10.4. Probe Holder Frame

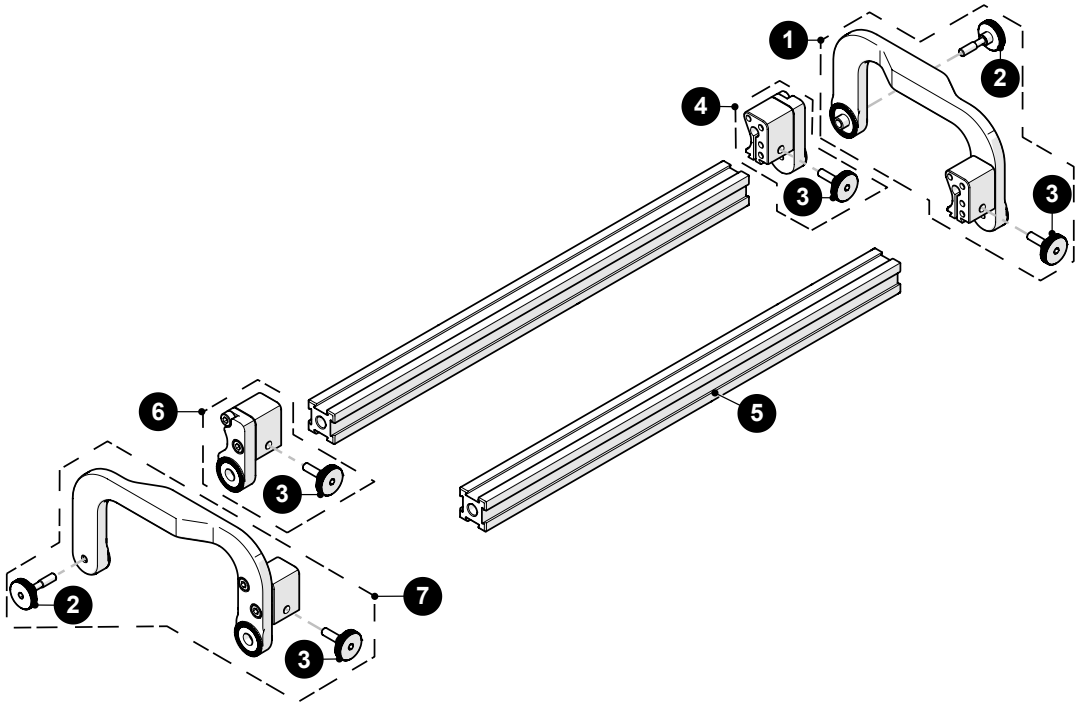

BOM ID	Part #	Description
1	CXS043	Vertical Probe Holder Side Arm, Left
2	CX0125	Knob, M4 x 16 mm
3	CX0126	Knurled Knob, M4 x 0.7 x 11.5 mm, 3 mm hex, 4 mm stand off, SST
4	CXS072-L	Arm Mount Block, Left
5	BG0038-X	Frame Bar ( <i>see Frame Bar</i> )
6	CXS072-R	Arm Mount Block, Right
7	CXS042	Vertical Probe Holder Side Arm, Right

Fig. 238 - Probe holder frame parts

## 10.5. Low Profile Probe Holder Frame

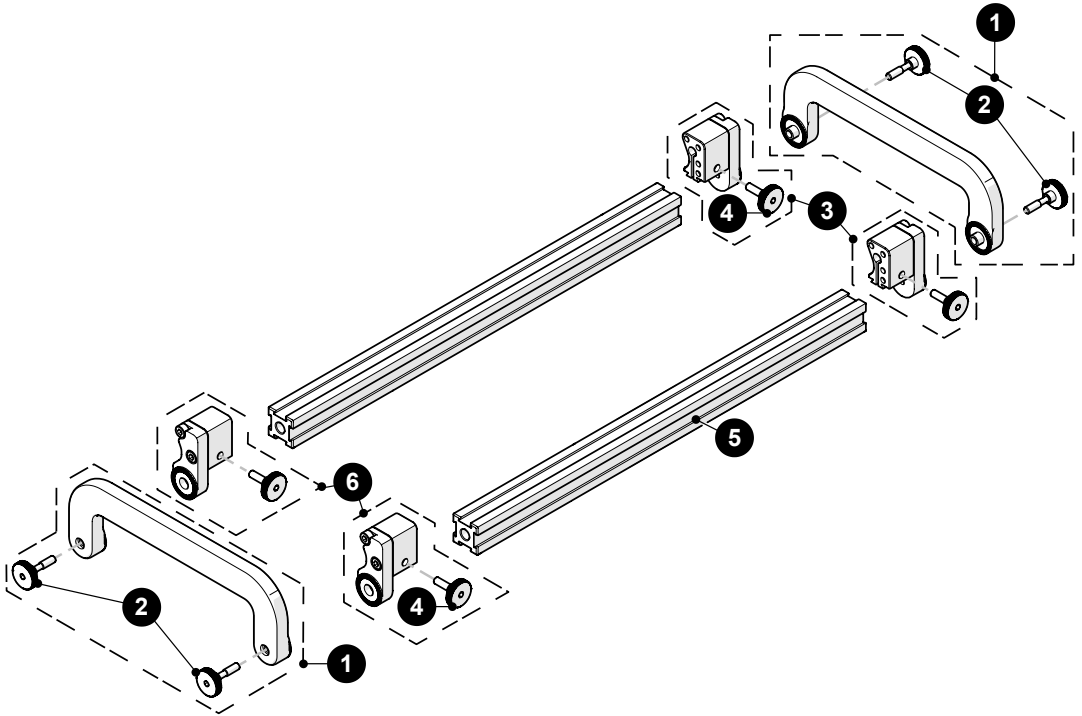

BOM ID	Part #	Description
1	CXS023	Low Profile Side Arm
2	CX0125	Knob, M4 x 16 mm
3	CXS072-L	Arm Mount Block, Left
4	CX0126	Knurled Knob, M4 x 0.7 x 11.5 mm, 3 mm hex, 4 mm stand off, SST
5	BG0038-X	Frame Bar ( <i>see Frame Bar</i> )
6	CXS072-R	Arm Mount Block, Right

Fig. 239 - Low profile probe holder frame parts

## 10.6. Pivoting Probe Holder Frame

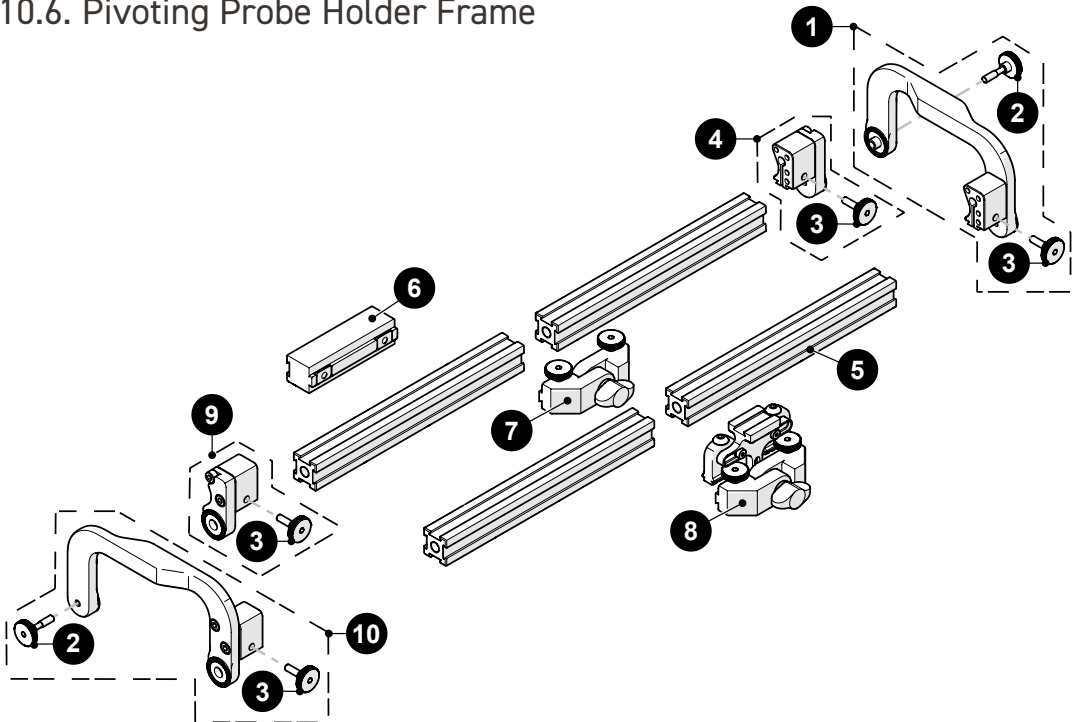

BOM ID	Part #	Description
1	CXS043	Vertical Probe Holder Side Arm, Left
2	CX0125	Knob, M4 x 16 mm
3	CX0126	Knurled Knob, M4 x 0.7 x 11.5 mm, 3 mm hex, 4 mm stand off, SST
4	CXS072-L	Arm Mount Block, Left
5	BG0038-X	Frame Bar ( <i>see Frame Bar</i> )
6	CXS064	NAVIC Front Spacer Mount
7	CXS055	Frame Bar Pivot
8	CXS059	Optical Guide Pivot Mount
9	CXS072-R	Arm Mount Block, Right
10	CXS042	Vertical Probe Holder Side Arm, Right

Fig. 240 - Pivoting probe holder parts

## 10.7. Slip Joint Probe Holder Parts

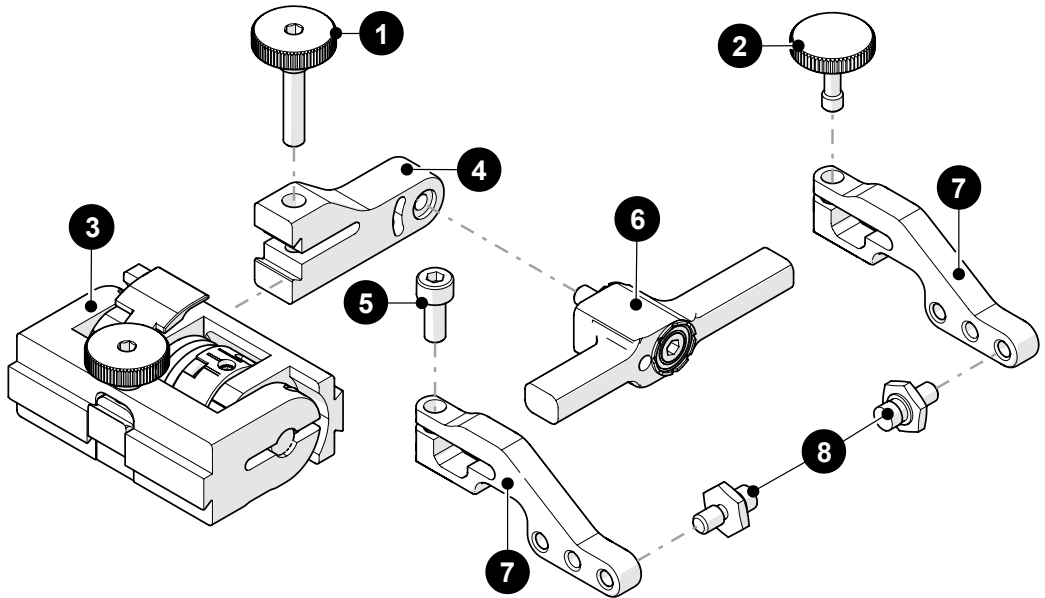

BOM ID	Part #	Description
1	PH0104	Knurled Knob, M4 x 0.7 x 18 mm, 4 mm stand off, SST
2	PH0082	Knurled Knob, M4 x 0.7 x 10 mm, 3 mm stand off, SST
3	PHS022	Slip Joint Probe Holder Subassembly
4		<i>see Swing Arm Style</i>
5	MD050-010	SHCS, M4 x 0.7 x 10 mm, SST
6		<i>see Yoke Style</i>
7		<i>see Arm Style</i>
8	PH0011-X	Pivot Button Style ( <i>see Pivot Button Style</i> )

Fig. 241 - Slip joint probe holder parts

## 10.8. Vertical Probe Holder Parts

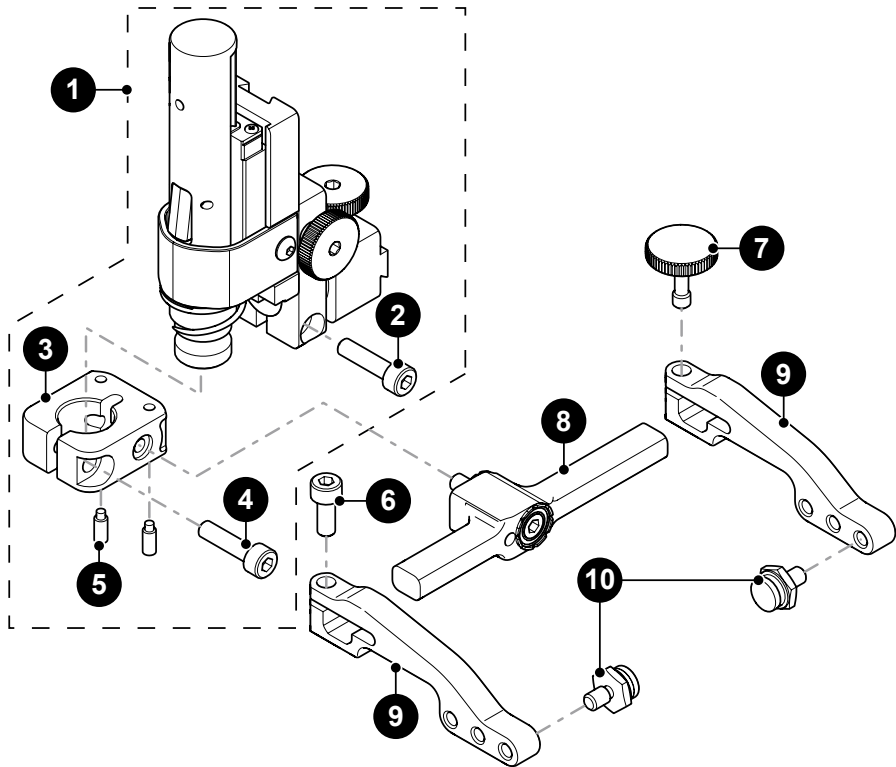

BOM ID	Part #	Description
1	PHS028	Vertical Probe Holder Subassembly
2	MA307	Screw, M4x16 mm High Strength SST SHCS
3	PH0087	Vertical Probe Holder Base
4	MD050-016	SHCS, M4 x 0.7 x 16 mm, SST
5	MA096	Screw, M3x8 mm Dog Point Set, SST
6	MD050-010	SHCS, M4 x 0.7 x 10 mm, SST
7	PH0082	Knurled Knob, M4 x 0.7 x 10 mm, 3 mm stand off, SST
8	see Yoke Style	
9	see Arm Style	
10	PH0011-X	Pivot Button Style (see Pivot Button Style)

Fig. 242 - Vertical probe holder parts

## 10.9. Heavy Duty Vertical Probe Holder

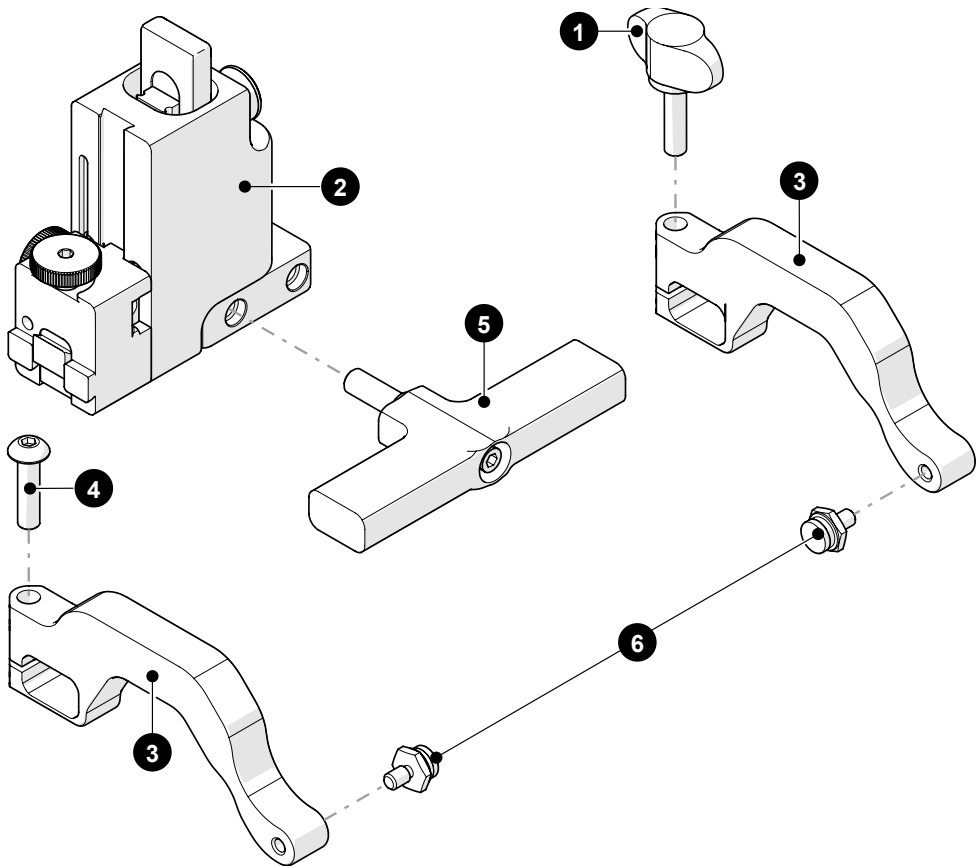

BOM ID	Part #	Description
1	EA154	Probe Holder Arm Adjustment Knob
2	PHS049	Heavy Duty Probe Holder Subassembly
3	PH0165	Heavy Duty Probe Holder Arm, Standard, Drop
4	MD074-020	BHCS, M5 x 0.8 x 20 mm, SST
5		See Heavy Duty Yoke Style
6	PH0011-X	Pivot Button Style (See Pivot Button Style)

Fig. 243 - Heavy duty vertical probe holder parts

## 10.10. Corrosion Thickness Probe Holder

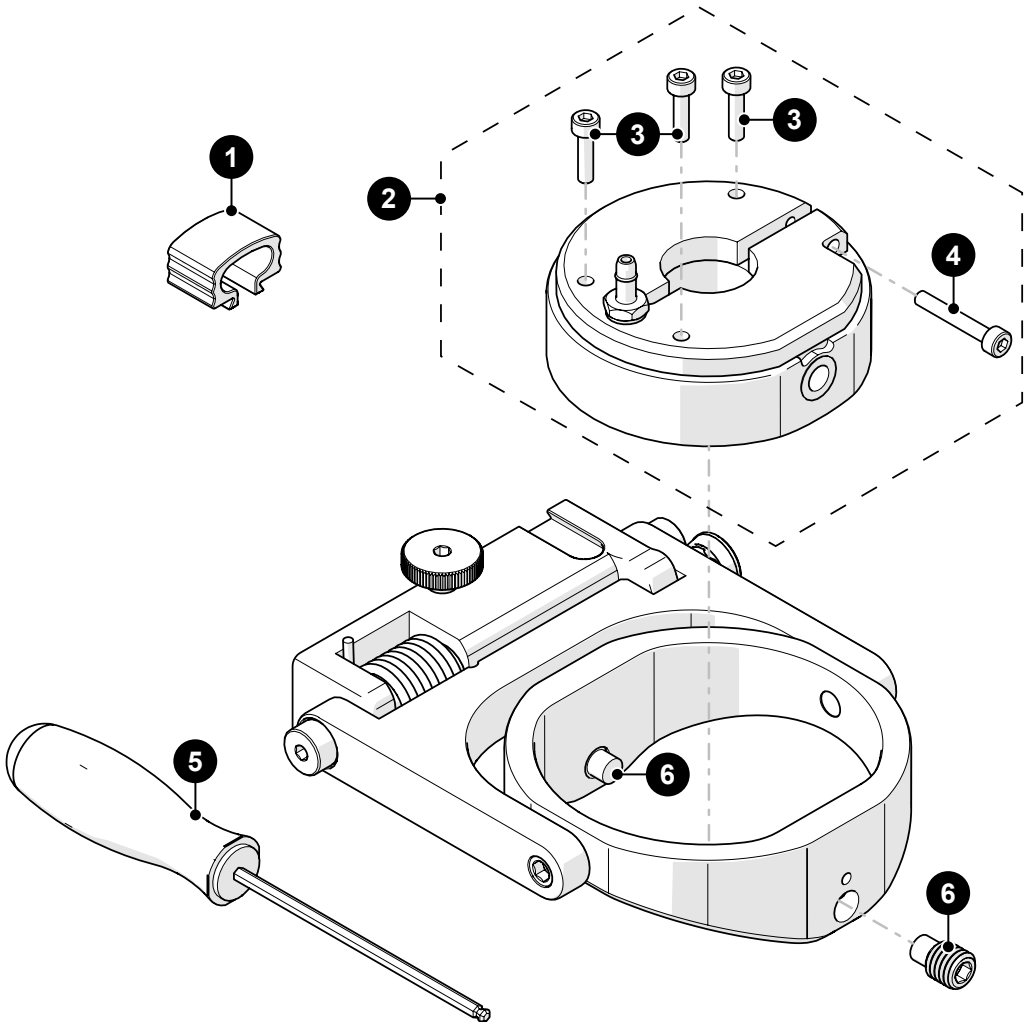

BOM ID	Part #	Description
1	BG0091	Cable Clip
2	<i>See Probe Holder Receptacle and Wear Plate</i>	
3	MD049-012	SHCS, M3x0.5 x 12 mm, SST
4	MD049-020	SHCS, M3x0.5 x 20 mm, SST
5	EA599	2.5 mm (0.098 in) Hex Driver
6	MA264	SHSS, M8 x 1.25 x 12 mm, dog point, SST

Fig. 244 - Corrosion thickness probe holder parts



# 10.11. Probe Holder Components

## 10.11.1. Arm Style









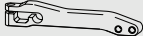

Arm Style	Part #		Arm Style	Part #	
<b>A</b> Standard, Flat	PH0090		<b>B</b> Short, Flat	PH0089	
<b>C</b> Long, Flat	PH0099		<b>D</b> Standard, Drop	PH0093	
<b>E</b> Short, Drop	PH0092		<b>F</b> Long, Drop	PH0094	
<b>G</b> Standard, Extra-Drop	PH0096		<b>H</b> Short, Extra-Drop	PH0095	
<b>I</b> Extra-Short, Flat	PH0159		<b>J</b> Extra-Short, Drop	PH0161	

Fig. 245 - Probe holder arm selection

## 10.11.2. Yoke Style

Yoke Style	Part #	Length		Yoke Style	Part #	Length	
<b>S</b> Standard	PHS052	6.3 cm (2.47 in)		<b>W</b> Wide	PHS063	7.9 cm (3.06 in)	

Fig. 246 - Probe holder yoke selection

## 10.11.3. Swing Arm Style

Swing Arm Style	Part #	Length		Swing Arm Style	Part #	Length	
Short	PH0069	4.1 cm (1.61 in)		Long	PH0100	4.6 cm (1.81 in)	

Fig. 247 - Swing arm selection

## 10.11.4. Heavy Duty Yoke Style

Yoke Style	Part #	Length		Yoke Style	Part #	Length	
<b>S</b> Standard	PHS048	8.3 cm (3.26 in)		<b>W</b> Wide	PHS047	12.2 cm (4.79 in)	

Fig. 248 - Heavy duty probe holder yoke selection

## 10.11.5. Pivot Button Style











Pivot Hole Size	Wedge Type		Pivot Hole Size	Wedge Type	
<b>01</b> 8.0 mm (0.315 in)	Olympus PA		<b>02</b> 5.0 mm (0.197 in)	Olympus TOFD	
<b>03</b> 2.7 mm (0.106 in)	Sonatest DAAH PA		<b>04</b> 9.5 mm (0.375 in)	-	
<b>06</b> 3.0 mm (0.118 in)	-		<b>07</b> 2.3 mm (0.09 in)	-	
<b>08</b> Conical Head	-		<b>09</b> 5 mm (0.197 in) Internal	Zetec PA/TOFD	
<b>11</b> 3 mm (0.118 in) Internal	-		<b>14</b> 4 mm (0.157 in)	-	

Fig. 249 - Pivot button selection

**NOTE:** Additional probe holder pivot button types available. (see "Jireh Industries Ltd." on page 1)

## 10.11.6. Probe Holder Receptacle and Wear Plate

Part #	Wear Plate	Receptacle		Part #	Wear Plate	Receptacle	
PHS066-A	Curved	9.53 mm (0.375 in) dia.		PHS066-B	Curved	12.7 mm (0.5 in) dia.	
PHS066-C	Curved	19 mm (0.75 in) dia.		PHS066-E	Curved	25.4 mm (1 in)	
PHS067-A	Flat	9.53 mm (0.375 in) dia.		PHS067-B	Flat	12.7 mm (0.5 in) dia.	
PHS067-C	Flat	19 mm (0.75 in) dia.		PHS067-D	Flat	Technisonic	
PHS067-E	Flat	25.4 mm (1 in)					

Fig. 250 - Pivot button selection

## 10.12. Variable Components

### 10.12.1. Frame Bar

Part #	Length		Part #	Length	
BG0038-05	5 cm (1.97 in)		BG0038-10	10 cm (3.94 in)	
BG0038-15	15 cm (5.91 in)		BG0038-20	20 cm (7.87 in)	
BG0038-25	25 cm (9.84 in)		BG0038-30	30 cm (11.81 in)	
BG0038-35	35 cm (13.78 in)		BG0038-40	40 cm (15.75 in)	
BG0038-45	45 cm (17.72 in)		BG0038-50	50 cm (19.69 in)	
BG0038-55	55 cm (21.65 in)				

Fig. 251 - Frame bar selection

## 10.13. Accessories

### 10.13.1. Automated Crawler Medium Temperature Add-On Kit

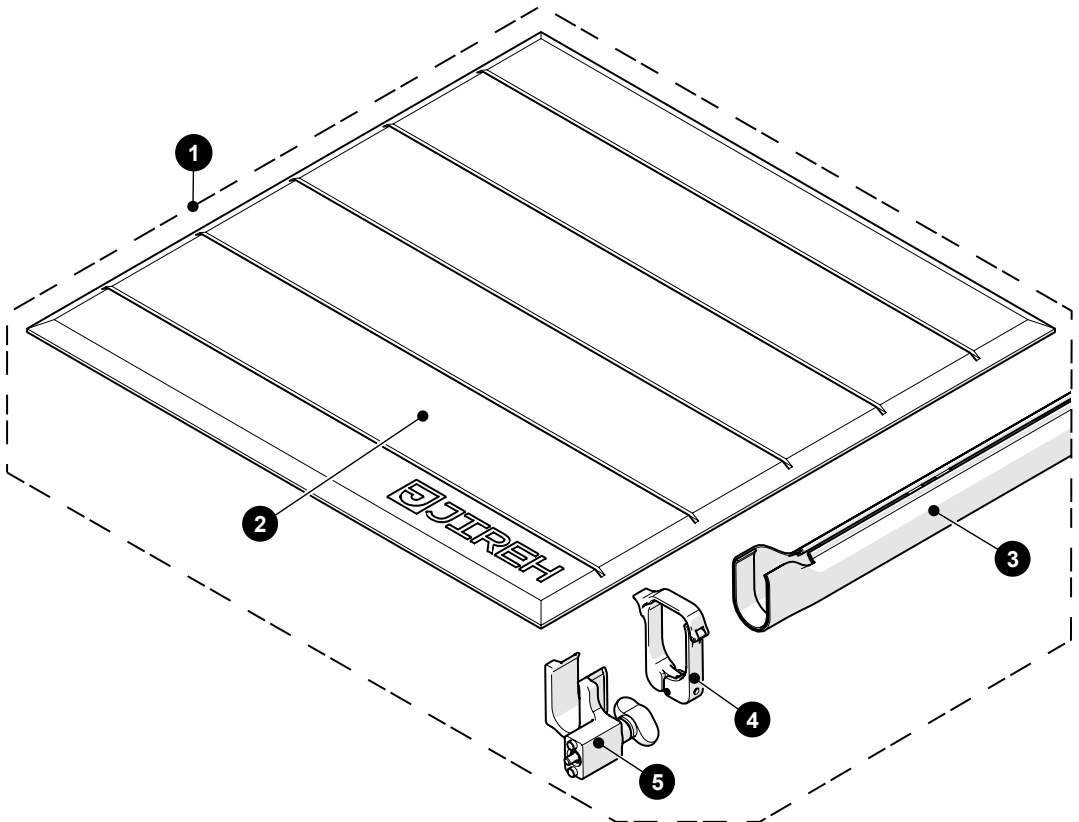

BOM ID	Part #	Description
1	CXG031-04.5	Automated Crawler Medium Temperature Add-On Kit
2	CXS102	Medium Temperature Installation/Removal Mat
3	CX0371-04.5	Medium Temperature Sleeve
4	CXS114	Medium Temperature Clamp
5	CXS112	Medium Temperature Mount

Fig. 252 - Automated Crawler Medium Temperature Add-On Kit

## 10.13.2. Preamp Bracket

Part #	Description
CES029	Preamp Bracket
CES029-V	Preamp Bracket with Velcro

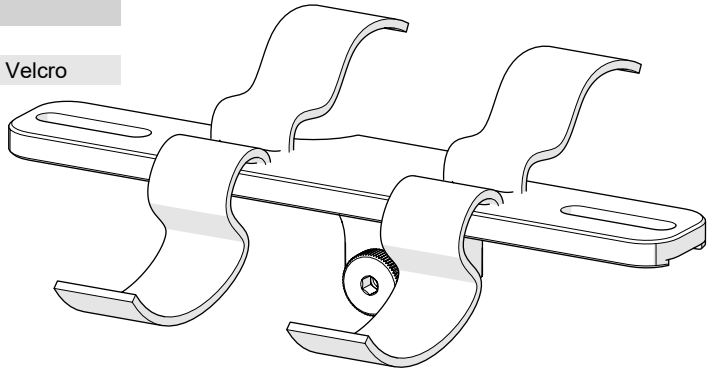
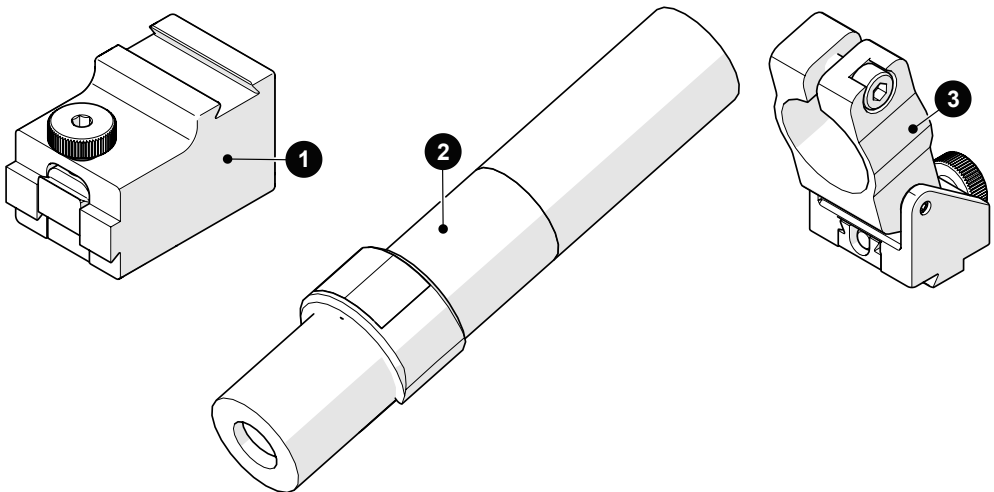

Fig. 253 - Preamp bracket

## 10.13.3. Battery Powered Optical Guide



BOM ID	Part #	Description
1	BGS068	Perpendicular Dovetail Mount
2	CX0490	Line Laser, Battery Powered, Class 1
3	CXS082	Optical Guide Clamp

Fig. 254 - Battery powered optical guide

## 10.14. Cases

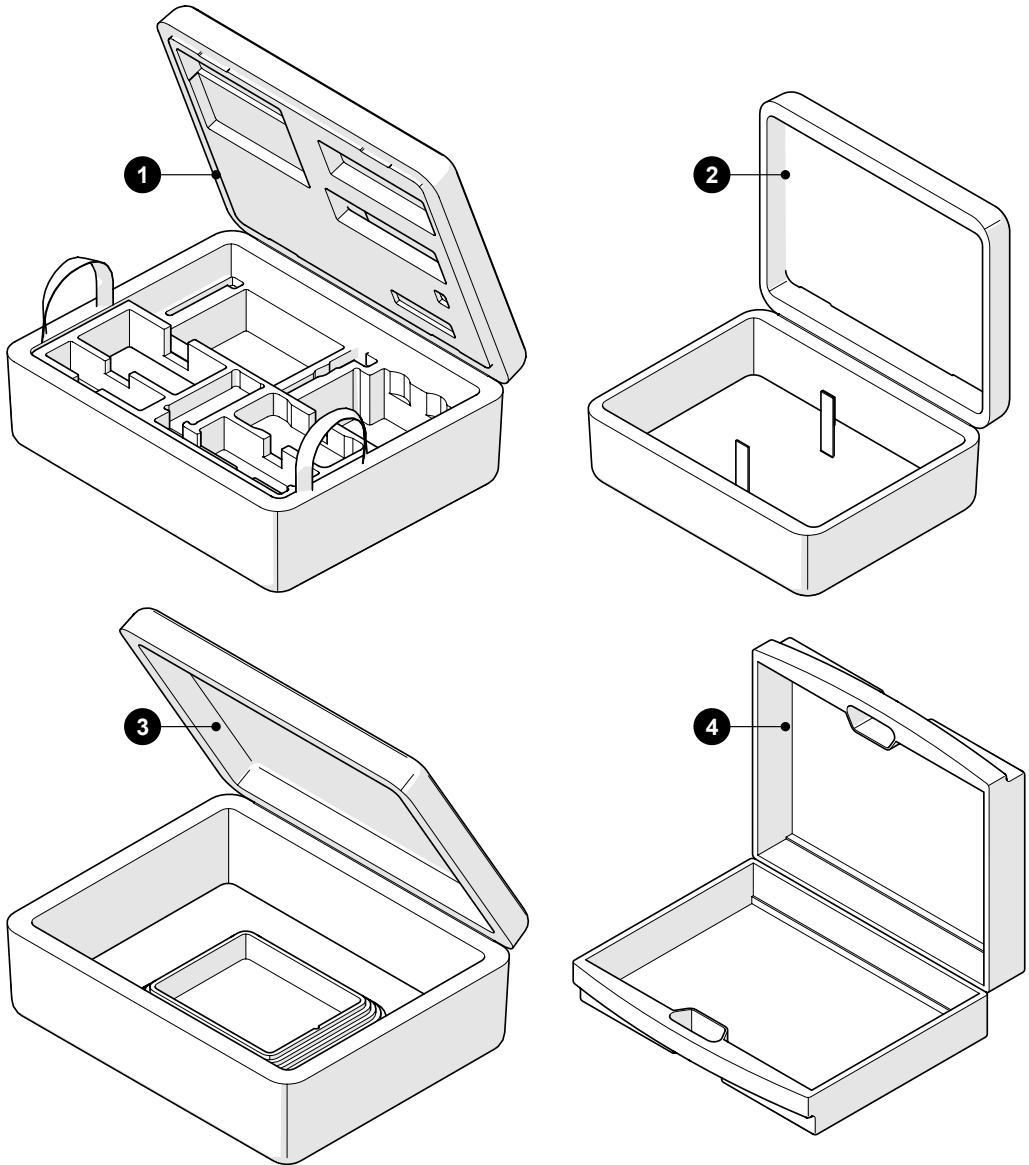

BOM ID	Part #	Description
1	DNA016	SKOOT Crawler Case
2	CXA023	Umbilical / Probe Holder Frame Case
3	CMA016	Motorized Pump / Umbilical Case
4	EA421	Umbilical Case

Fig. 255 - Cases

## DISPOSAL

### WEEE Directive

In accordance with European Directive on Waste Electrical and Electronic Equipment (WEEE), this symbol indicated that the product must not be disposed of as unsorted municipal waste, but should be collected separately. Refer to Jireh Industries for return and/or collection systems available in your country.



## LIMITED WARRANTY

### WARRANTY COVERAGE

Jireh Industries warranty obligations are limited to the terms set forth below: Jireh Industries Ltd. (“Jireh”) warrants this hardware product against defects in materials and workmanship for a period of THREE (3) YEARS from the original date of purchase. If a defect exists, at its option Jireh will (1) repair the product at no charge, using new or refurbished replacement parts, (2) exchange the product with a product that is new or which has been manufactured from new or serviceable used parts and is at least functionally equivalent to the original product, or (3) refund the purchase price of the product. A replacement product/part assumes the remaining warranty of the original product or ninety (90) days from the date of replacement or repair, whichever provides longer coverage for you. When a product or part is exchanged, any replacement item becomes your property and the replaced item becomes Jireh’s property. When a refund is given, your product becomes Jireh’s property.

### OBTAINING WARRANTY SERVICE

To utilize Jireh’s warranty service you must ship the product, at your expense, to and from Jireh Industries. Before you deliver your product for warranty service you must phone Jireh and obtain an RMA number. This number will be used to process and track your product. Jireh is not responsible for any damage incurred during transit.

### EXCLUSIONS AND LIMITATIONS

This Limited Warranty applies only to hardware products manufactured by or for Jireh Industries. This warranty does not apply: (a) to damage caused by accident, abuse, misuse, misapplication, or non-Jireh products; (b) to damage caused by service (including upgrades and expansions) performed by anyone who is not a Jireh Authorized Service Provider; (c) to a product or a part that has been modified without the written permission of Jireh.

**Jireh Industries Ltd.**  
53158 Range Road 224  
Ardrossan, AB T8E 2K4  
Canada

Phone: 780-922-4534

[jireh.com](http://jireh.com)

HydroFORM™ is a trademark of Olympus.

All brands are trademarks or registered trademarks of their respective owners and third-party entities.

Changes or modifications to this unit or accessories not expressly approved by the party responsible for compliance could void the user's authority to operate the equipment.

All specifications are subject to change without notice.

© 2021 - 2024 Jireh Industries Ltd.





Jireh Industries Ltd.  
53158 Range Road 224  
Ardrossan, Alberta  
Canada  
T8E 2K4

780-922-4534

[jireh.com](http://jireh.com)